

Sampling Phase Detectors



SPD1101-111, SPD1102-111, SPD1103-111

Features

- For Phase Locked VCOs to 22 GHz
- Reference Frequencies Below 50 MHz
- New Surface Mount Package Design
- Small Footprint (90 x 110 Mils)
- Automated Chip on Board Construction

Description

Alpha has redesigned its product line of sampling phase detectors using automated chip on board manufacturing technology to provide a more uniform, surface mountable, small footprint device without sacrificing the microwave performance of the original design.

Sampling phase detectors are used to phase lock a microwave VCO to a stable reference source at a submultiple frequency. The sampling phase detector consists of a step recovery diode, capacitors and a microwave mixer consisting of series pair Schottky diodes. The principle of operation may be described as using the step recovery diode to generate a harmonic comb of the reference oscillator frequency and the Schottky diode as a mixer between the closest reference frequency multiple and the microwave signal generated by the VCO. When these frequencies are identical the IF (beat note) signal is a DC voltage; the IF will be sinusoidal when the frequencies are unequal.

The SPD1100 series sampling phase detectors use a selected step recovery diode chip whose carrier lifetime and transition time are appropriate for use in applications allowing reference frequencies below 50 MHz and microwave VCO frequencies as high as 22 GHz. The

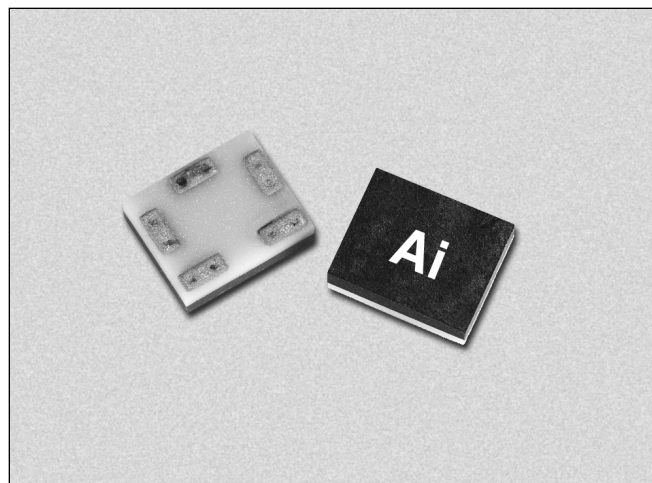

Schottky diodes used are low capacitance devices capable of efficient mixer performance at frequencies above 22 GHz. The SPD1101-111, SPD1102-111 and SPD1103-111 utilize low, medium and high barrier Schottky diodes and may be selected according to the available power generated by the microwave VCO.

Absolute Maximum Ratings

Characteristic	Value
Incident Power	27 dBm
Operating Temperature	-65 to +150°C
Storage Temperature	-65 to +175°C
ESD Human Body Model	Class 1B

Electrical Characteristics at 25°C

Part Number	Microwave Signal Drive Level (dBm)	Schottky Diode				Capacitor C _C (pF)	Step Recovery Diode		
		Barrier	V _F @ 1 mA (mV)	C _J @ 0 V (pF)	R _T @ 5 mA (Ω)		C _J @ 6 V (pF)	T _L (nS)	TT (pS)
SPD1101-111	-3 to 0	Low	270–350	0.10	24	0.5	0.25	10	70
SPD1102-111	0 to +3	Medium	370–550	0.10	24	0.5	0.25	10	70
SPD1103-111	0 to +13	High	600–700	0.10	24	0.5	0.25	10	70

Typical Performance

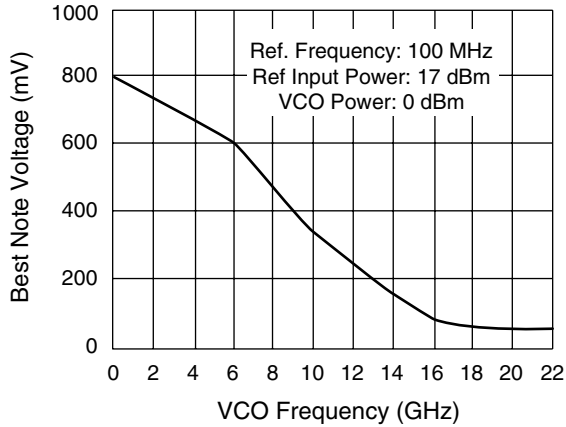

SPD1101-111

Suggested Circuit

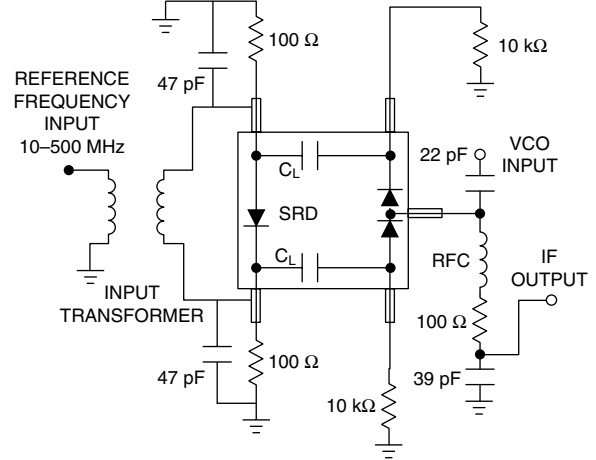

Input transformer: 10:1 step down impedance ratio.

Schematic Diagram

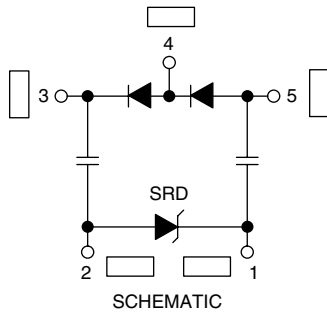

-111 Package Outline

