

High Speed Differential APC Amplifier

FEATURES

- Dual Wavelength
- Slew Rate of 300V/ μ s
- Fast Settling Time - 7ns
- Gain Control
- 2V Output Swing
- Low Offset Voltage: < 10mV
- Low Offset Drift: < 20 μ V/ $^{\circ}$ C
- 12dB External Gain Adjust Range

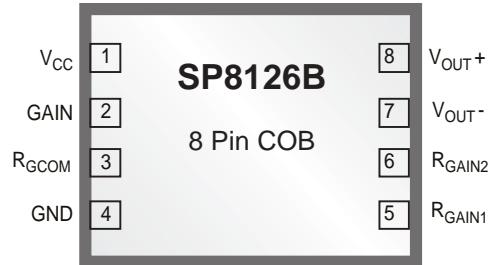

APPLICATIONS

- DVDRW
- DVD RAM
- CDRW

DESCRIPTION

The SP8126B is a high-speed, differential output APC amplifier that integrates the photodiode and adjustable gain block on one chip. Independent gain control allows individual adjustment for 780nm and 650nm wavelength operation, as found in CD/DVD optical storage drives. This allows the user to control the laser power of the system in high-speed DVDRW, DVD RAM and CDRW systems. The wide 2V output swing also allows better system performance, through improved dynamic range.

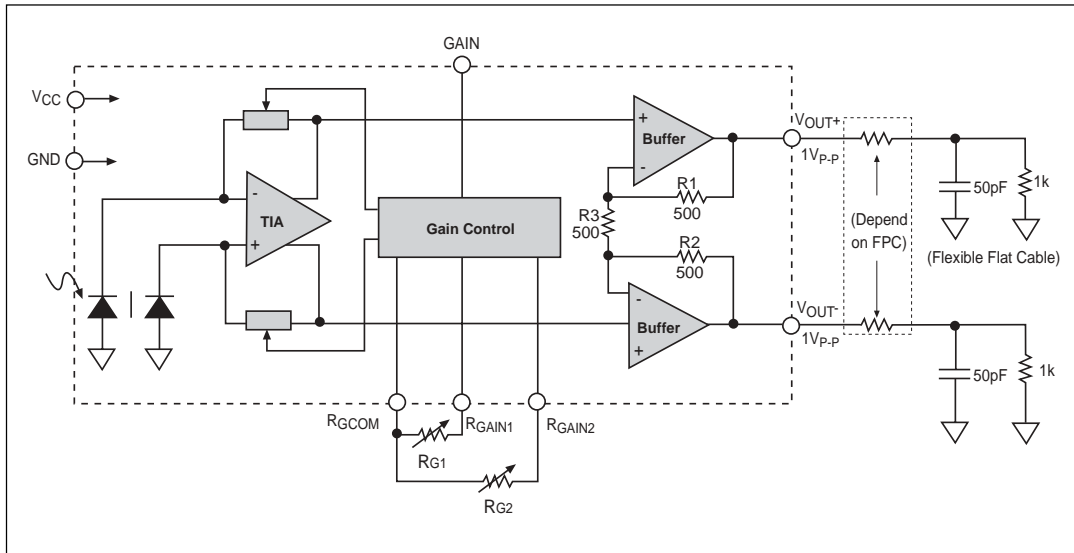

Figure 1. SP8126B Functional Diagram and Typical Application

ABSOLUTE MAXIMUM RATINGS

T _J (MAX)	120°C
V _S (MAX)	6V
V _{IN} (MAX)	6V

These are stress ratings only and functional operation of the device at these ratings or any other above those indicated in the operation sections of the specifications below is not implied. Exposure to absolute maximum rating conditions for extended periods of time may affect reliability.

Power Supply Voltage

Continuous Power Dissipation (T_{AMB} = 70°C)

COB (derate 13.3mW/°C above +70°C) 90mW

ELECTRICAL SPECIFICATIONS

Unless otherwise noted: V_{CC} = 5.0V, C_{LOAD} = 50pF to GND, R_{LOADP} = R_{LOADN} = 1kΩ to GND, R_{GAIN} = 510Ω (Nominal Gain), -20°C ≤ T_A ≤ +85°C, Output measured differentially.

PARAMETER	CONDITIONS	MIN	TYP	MAX	UNITS
Supply Voltage		4.5	5	5.5	V
Output Sensitivity	Laser Beam Diameter = 0.70mm, uniform density	2400	3000	3600	V/W
Output Sensitivity vs. Temp	R _{GAIN} =1230Ω			0.1	%/C
Output Sensitivity vs. V _{cc}	R _{GAIN} =1230Ω			2	%/V
Input Optical Power Required to Produce 2V Output Swing		533	666	800	μW
Full Scale Linear Output Voltage Swing		2	2.8		V
Output Common Mode Voltage		2.3	2.5	2.7	V
	4.5V < V _{cc} < 5.5V	V _{cc} /2.2	V _{cc} /2	V _{cc} /1.8	V
Output Offset Voltage		-10	0.5	10	mV
	R _{GAIN} = 1230Ω (High Gain)	-20	1.0	20	mV
Output Offset Voltage Drift		-25	-11	25	μV/C
	R _{GAIN} = 1230Ω (High Gain)	-50	-13	50	μV/C
Output Noise	BW = 100MHz		1.6	2	mVrms
	BW = 100MHz, R _{GAIN} = 1230Ω (High Gain)		2.4	5	mVrms
Bandwidth	-3dB	70	100		MHz
	-3dB, R _{GAIN} = 1230Ω (High Gain)	50	68		MHz
PSRR	4.5V < V _{cc} < 5.5V	55	76		dB
	4.5V < V _{cc} < 5.5V, R _{GAIN} = 1230Ω (High Gain)	50	73		dB
Output Settling Time(650nm) (1% of Final Value)	2V _{PP} Step		7	10	ns
	2V _{PP} Step, R _{GAIN} = 1230Ω (High Gain)		12	15	ns

ELECTRICAL SPECIFICATIONS: Continued

Unless otherwise noted: $V_{CC} = 5.0V$, $C_{LOAD} = 50pF$ to GND, $R_{LOADP} = R_{LOADN} = 1k\Omega$ to GND, $R_{GAIN} = 510\Omega$ (Nominal Gain), $-20^{\circ}C \leq T_A \leq +85^{\circ}C$, Output measured differentially.

PARAMETER	CONDITIONS	MIN	TYP	MAX	UNITS
Output Settling Time (780nm) (1% of Final Value)	$2V_{PP}$ Step		10	13	ns
	$2V_{PP}$ Step, $R_{GAIN} = 1230\Omega$ (High Gain)		15	18	ns
Output Slew Rate		200	300		V/ μ s
Output Overshoot	$2V_{PP}$ Step			5	%
Power Supply Current			15		mA
	$-20^{\circ}C < T_A < +85^{\circ}C$			20	mA
Gain Adjust Range	$225\Omega < R_{GAIN} < 1230\Omega$	-6		6	dB
Gain Select Input Voltage VIL (TTL Level)				0.8	V
Gain Select Input Voltage VIH (TTL Level)		2.0			V

PIN DESCRIPTION

PIN NUMBER	NAME	FUNCTION
1	V_{CC}	Supply Voltage
2	GAIN	Gain Select
3	R_{GCOM}	Common connection point for R_{GAIN1} and R_{GAIN2}
4	GND	Power Ground
5	R_{GAIN1}	Gain Adjust 1 (Gain Select = LOW) or OPEN
6	R_{GAIN2}	Gain Adjust 2 (Gain Select = HIGH)
7	V_{OUT-}	Output Voltage -
8	V_{OUT+}	Output Voltage +

THEORY OF OPERATION

Internal Operation

The SP8126B APC circuit has an integrated photo detector and is designed with nominal sensitivities of $3mV/\mu W$ for both 650nm and 780nm wavelength laser light. The part's sensitivity can also be adjusted continuously and independently for two different gain modes via two external resistors over a range of $\pm 6dB$. The two gain modes are controlled by a TTL compatible logic input, called GAIN SELECT. This logic pin selects between the two external gain setting resistors to allow independent control and settings for the two gain functions.

The system is a two stage design, consisting of a Trans-Impedance Amplifier (TIA) and an output buffer stage. In dark condition the outputs V_{OUT-} and V_{OUT+} are set to a reference voltage

that is defined internally as $V_{CC}/2$. With 650nm or 780nm wavelength laser light falling on the photodetector, the output will swing differentially around $V_{CC}/2$ proportional with the light power according to the chosen gain.

TIA and Gain control

The first stage is a differential TIA used to convert the photodetector current to a balanced differential voltage. The traditional fixed feedback resistors have been replaced with an active resistor circuit that sets the trans-impedance value.

A Resistor Control Block that senses the value of the external gain setting resistor controls the value of the equivalent feedback resistor.

The $\pm 6\text{dB}$ Gain adjustment is therefore done directly in the TIA, by adjusting the active feedback blocks proportional with the gain setting resistor. The external resistor is not directly in the signal path, and therefore any parasitic from the off-chip connections does not affect the signal quality. The value of the active feedback is controlled tightly over supply and temperature changes through a Control Block with active feedback circuitry.

Gain control is proportional with the external resistor, so the lowest value of R_{GAIN} will produce the -6dB gain adjustment and the highest value will produce the $+6\text{dB}$ gain adjustment. Please consult the specification table for the required R_{GAIN} values.

Buffer

This stage buffers the differential signal from the TIA to the V_{OUT} pins and refers the signal to the internal reference voltage. A balanced current feedback amplifier is used for this purpose to achieve high slew rate and fast settling.

The buffer is designed to drive high capacitive loads. The maximum load is 50pF bulk. The actual load is typically a flexible printed circuit (FPC) that acts like a transmission line. This presents a distributed capacitive load plus inductance and resistance. In this case care should be taken to match the characteristic impedance of the line at the far end to avoid standing waves and ringing. The buffer is designed to drive $1\text{k}\Omega$ to ground. However, this resistor can be adjusted in value to accommodate the characteristic impedance of the signal trace. The output buffer amplifier is designed to be stable without load and with loads up to 50pF lumped capacitance.

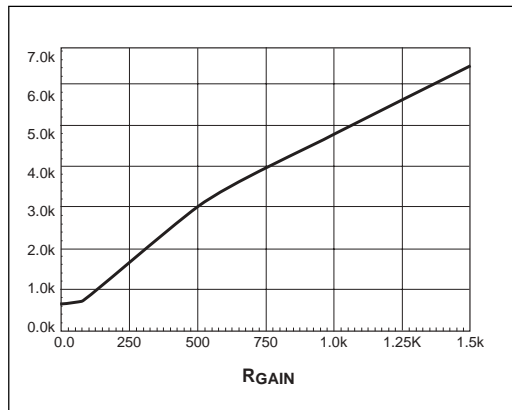

Figure 2. Sensitivity versus R_{GAIN}

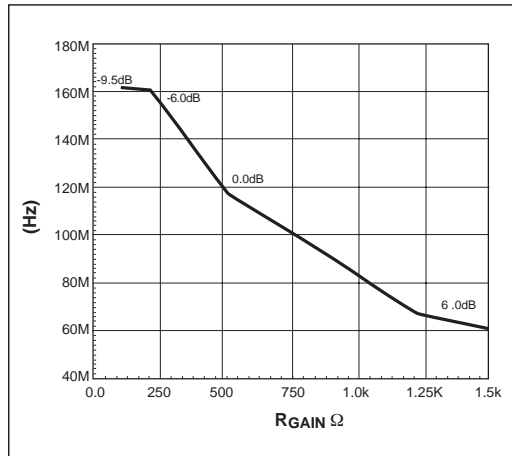

Figure 3. Bandwidth versus R_{GAIN}

TABLE 1: APC SYSTEM TARGET GAIN SET POINTS.

$V_{\text{OUTP}} - V_{\text{OUTN}} = 2V_{\text{P-P}}$, $V_{\text{CC}} = 5\text{V}$, $T = 27^\circ\text{C}$

Gain (dB)	Sensitivity (V/W)	R_{GAIN} (Ω)	T_s 1% (nS)	BW (MHz)	Pin (μW)
+6	6000	1230	12	68	335
0	3000	510	7	119	666
-6	1500	225	5.5	160	1331

LAYOUT AND ROUTING CONSIDERATIONS

A major consideration in developing the optical pick-up head system is the extremely small form factor, which is additionally aggravated by the physical locations required by the light path.

Special care must be taken when designing the Flex or PCB for this part. The output peak current requirement is in the order of 12.5mA when driving 50pF of capacitive load with a slew rate of 250V/ μ s. Therefore care must be taken to provide low inductance, low resistance paths for power and ground and output traces.

Supply coupling is also very important. Good supply decoupling is important to ensure the high frequency performance of the system by eliminating supply lead inductance effects. The decoupling capacitor C1, as shown in Figure 5, should be as close to the part as possible. This

capacitor should be 0.1 μ F ceramic. C2 is optional to improve decoupling and is recommended to be 1 μ F tantalum. The layout of the PCB is pictured here. Note the wide and short traces on the supply lines.

The traces for the gain resistors R_{GAIN1} and R_{GAIN2} are kept as short as possible to avoid excessive parasitics. Any parasitics on these nodes will limit the performance of the system. R_{GAIN1} and R_{GAIN2} are subminiature potentiometers in the application. This is a single layer board using FR4 material.

In order to minimize coupling capacitance into the gain setting resistor nodes, it is also critical that V_{OUT+} and V_{OUT-} are routed away from the traces associated with the gain-setting resistors.

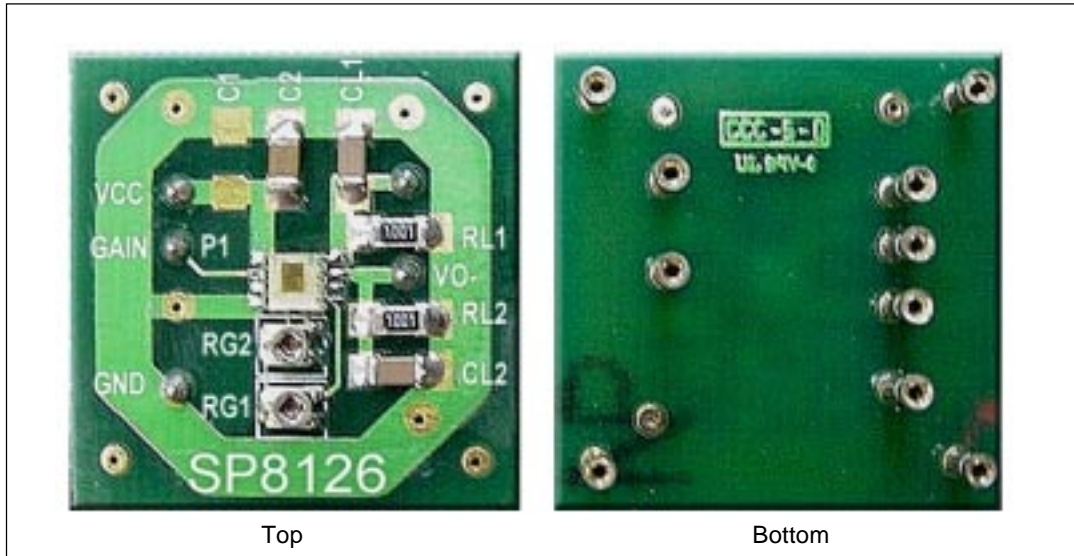

Figure 4. Test and Evaluation PCB Layout for COB 8 Lead Package

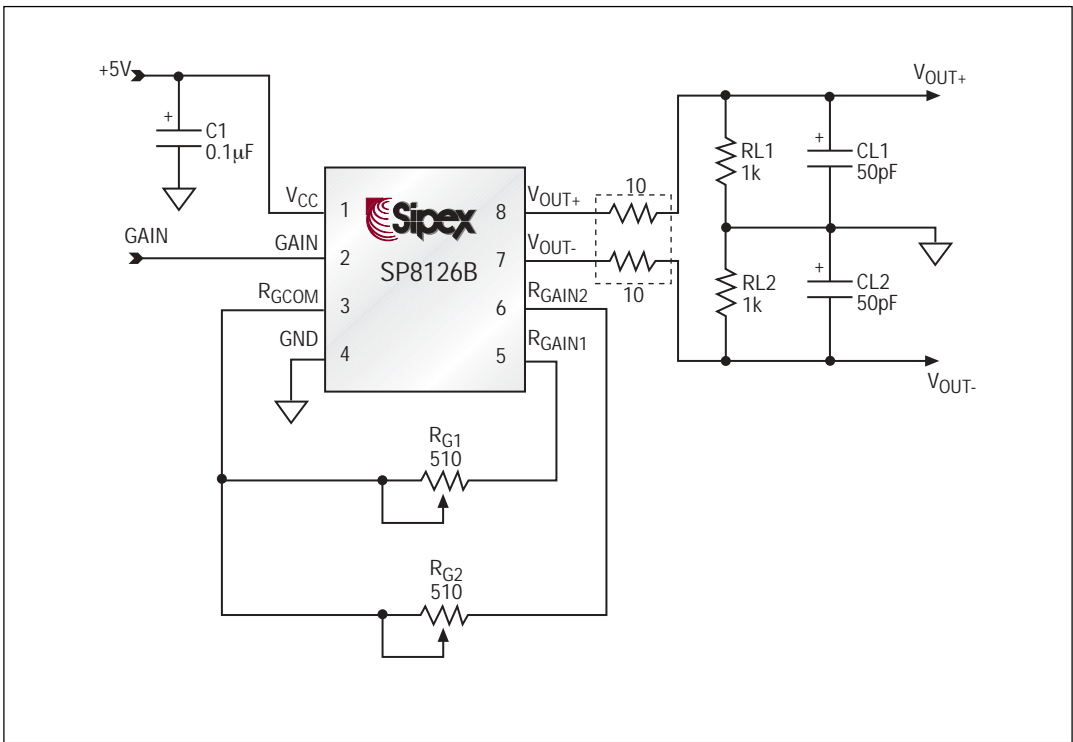
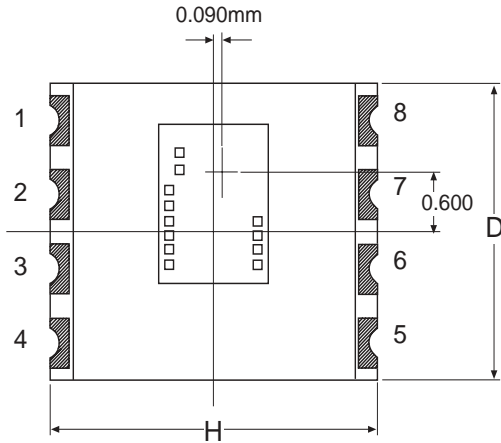
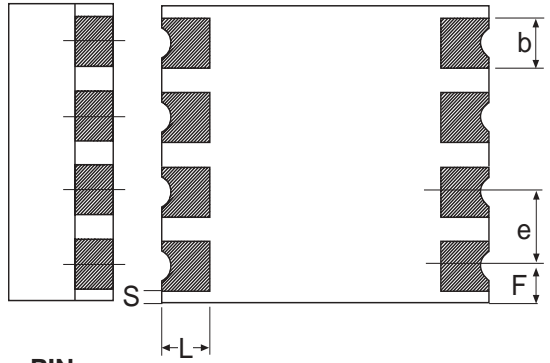

Figure 5. Test and Evaluation Schematic



TOP VIEW



PIN SIDE VIEW

BOTTOM VIEW

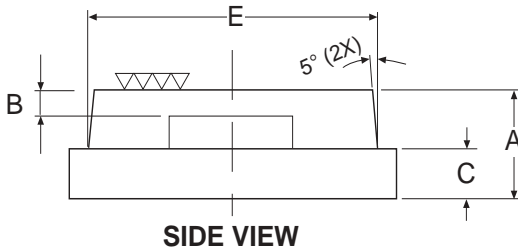

SIDE VIEW

DETECTOR SIZE

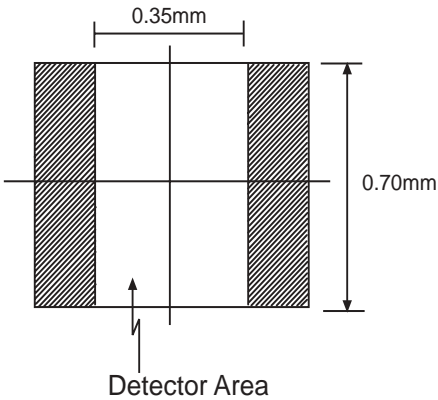

DIMENSIONS in mm Min/Max	8-PIN COB
A	0.90/1.10
B	0.127/0.33
b	0.30/0.50
C	0.50 nom
D	2.90/3.10
E	3.00/3.20
e	0.75 nom
H	3.40/3.60
L	0.40/0.60
F	0.28/0.48
S	0.075/0.275

**8 PIN COB
(3.0mm X 3.5mm)**

ORDERING INFORMATION

Part Number	Temperature Range	Package Type
SP8126CB-3	-20°C to +85°C	8 lead COB (3.0mm x 3.5mm)



ANALOG EXCELLENCE

Sipex Corporation

**Headquarters and
Sales Office**
233 South Hillview Drive
Milpitas, CA 95035
TEL: (408) 934-7500
FAX: (408) 935-7600

Sales Office
22 Linnell Circle
Billerica, MA 01821
TEL: (978) 667-8700
FAX: (978) 670-9001
e-mail: sales@sipex.com

Sipex Corporation reserves the right to make changes to any products described herein. Sipex does not assume any liability arising out of the application or use of any product or circuit described herein; neither does it convey any license under its patent rights nor the rights of others.