



Obsolescence Notice

This product is obsolete.

This information is available for your convenience only.

For more information on Zarlink's obsolete products and replacement product lists, please visit http://products.zarlink.com/obsolete_products/



SP1658BC

T-50-15

VOLTAGE-CONTROLLED MULTIVIBRATOR (CONFORMS TO MIL-STD-883C CLASS B)

The SP1658 is a voltage-controlled multivibrator which provides appropriate level shifting to produce an output compatible with ECL III and ECL 10,000 logic levels. Frequency control is accomplished through the use of voltage-variable current sources which control the slew rate of a single external capacitor.

The bias filter may be used to help eliminate ripple on the output voltage levels at high frequencies and the input filter may be used to decouple noise from the analog input signal.

The SP1658 is useful in frequency modulation, phase-locked loops, frequency synthesiser and clock signal generation applications for instrumentation, communication and computer systems.

FEATURES

- MIL-M-38510 Change Notification Observed
- Full Quality Conformance Inspection
- Operating temperature range: -30°C to +85°C
- Supply Voltages -5.2V, 0V
- Oscillator Frequency Range 0.1 - 100MHz
- Voltage Controlled

CHANGE NOTIFICATION

The change notification requirements of MIL-M-38510 will be implemented on this device type. Known customers will be notified of any changes since last buy when ordering further parts if significant changes have been made.

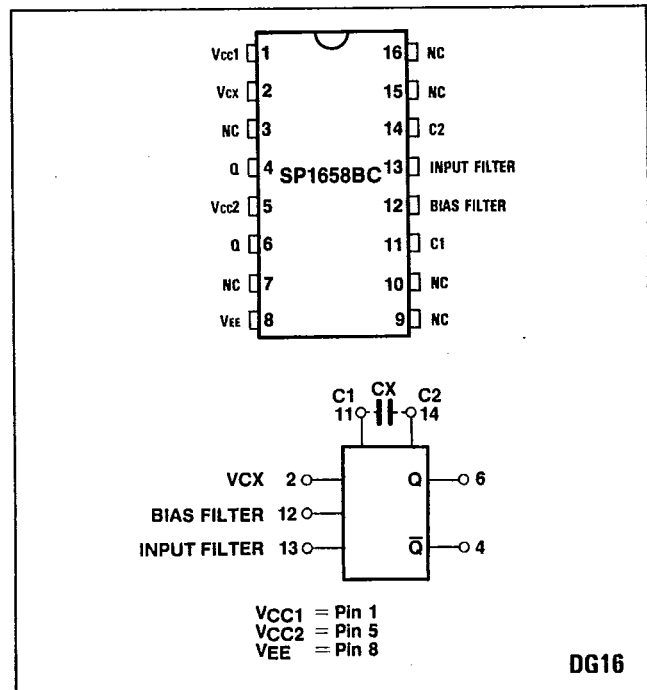

Fig.1 Pin connections (top view) and block diagram

ORDERING INFORMATION

SP1658BC DG (Commercial - ceramic package)

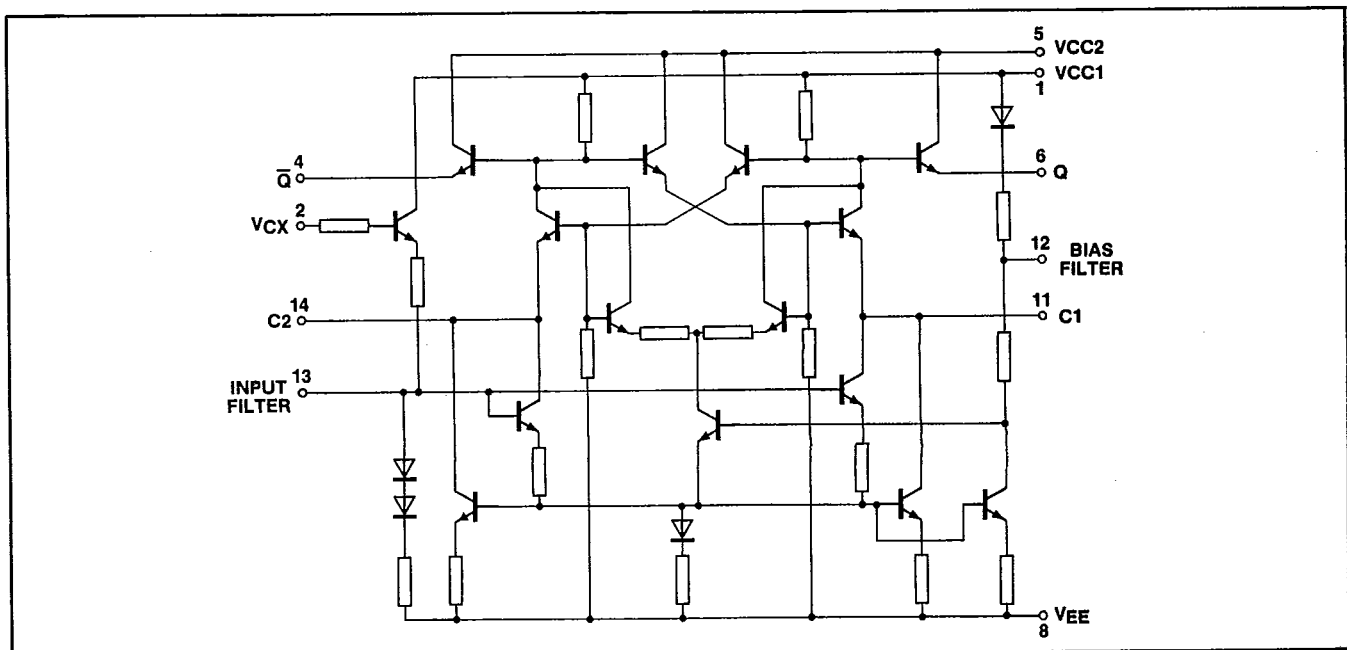

Fig.2 Circuit diagram

Rev.	A		
Date	1 Feb 87		

ELECTRICAL CHARACTERISTICS

Test conditions (unless otherwise stated):

$V_{CC1} = V_{CC2} = 0V$; $V_{EE} = -5.2V \pm 0.01V$

Parameter	Symbol	Value		Sub group	Notes	Method/Conditions/Temp.
		Min.	Max.			
Supply current	I_{EE}		32mA	1,2,3	1	
Control input current	I_{CX}		350 μ A		1	$V_{CX} = 0V$
		-0.5 μ A			1	$V_{CX} = -2V$
Logic high output voltage	V_{OH}	-0.960V	-0.810V	1	1	$T_{amb} = +25^{\circ}C$
		-0.890V	-0.700V	2	1	$T_{amb} = +85^{\circ}C$
		-1.045V	-0.875V	3	1	$T_{amb} = -30^{\circ}C$
Logic low output voltage	V_{OL}	-1.850V	-1.620V	1	1	$T_{amb} = +25^{\circ}C$
		-1.830V	-1.575V	2	1	$T_{amb} = +80^{\circ}C$
		-1.890V	-1.650V	3	1	$T_{amb} = -30^{\circ}C$
Oscillator frequency	f_{osc}	78MHz	120MHz	4	2	$C_x = 10pF$ $T_{amb} = +25^{\circ}C$ $V_{CX} = V_{CC}$
				5,6	2	$C_x = 10pF$ $T_{amb} = -30^{\circ}C$ to $+85^{\circ}C$ $V_{CX} = V_{CC}$
Timing ratio test	TR	3.1	-	4,5,6	2,3	$C_x = 10pF$ $T_{amb} = -30^{\circ}C$ to $+85^{\circ}C$
Function test		-	-	7,8	4	

NOTES

1. The static tests are carried out with a Germanium diode connected between pins 11 and 14; anode to 11 gives Q high, cathode to 11 gives Q low.
2. The test configuration for dynamic testing is shown in Fig.3.
3. The Tuning Ratio is defined as (output frequency at $V_{CX} = V_{CC}$)/(output frequency at $V_{CX} = V_{CC} - 2V$).
4. The Function Test is performed in conjunction with the Oscillator Frequency tests (sub group 4,5 or 6).
5. Sub groups 9,10,11 are not required.

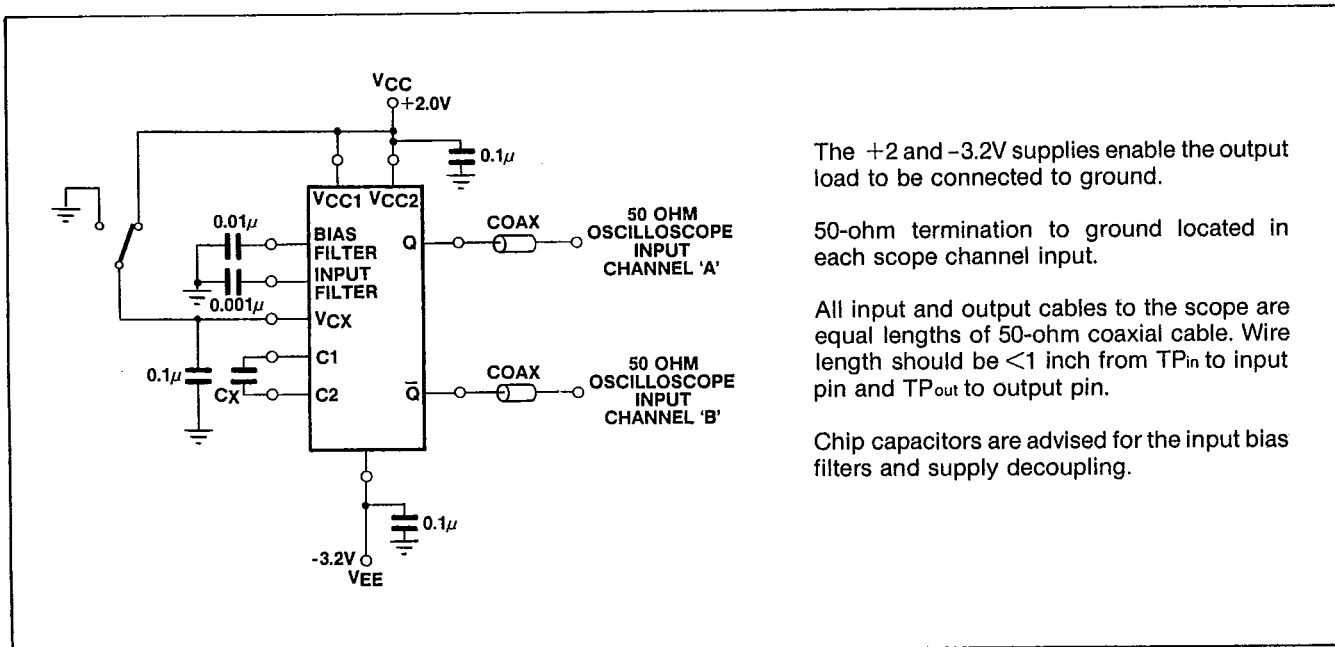

Fig.3 Dynamic test circuit

The +2 and -3.2V supplies enable the output load to be connected to ground.

50-ohm termination to ground located in each scope channel input.

All input and output cables to the scope are equal lengths of 50-ohm coaxial cable. Wire length should be <1 inch from TP_{in} to input pin and TP_{out} to output pin.

Chip capacitors are advised for the input bias filters and supply decoupling.

ABSOLUTE MAXIMUM RATINGS

Power supply	$ V_{CC} - V_{CC} $ 8V
Output source current	<15mA
V _{CX} input	-2.5V to 0V w.r.t. V _{CC}
Storage temperature range	-55°C to +150°C

Operating junction temperature
Thermal characteristics DG16

<175°C
 $\theta_{JA} = 120^{\circ}C/W$
 $\theta_{JC} = 40^{\circ}C/W$

T-50-15

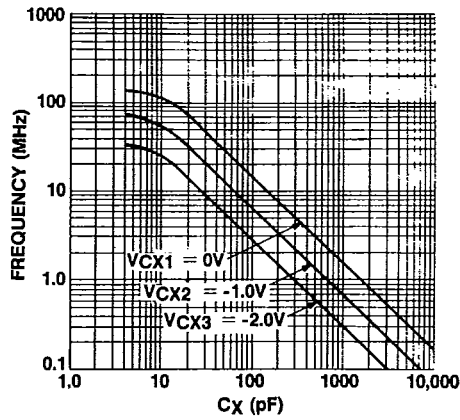

Fig.4 Output frequency v. capacitance for three values of input voltage

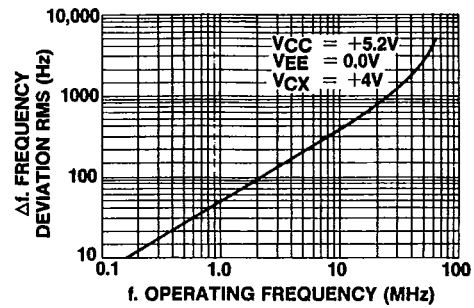

Fig.5 RMS noise deviation v. operating frequency

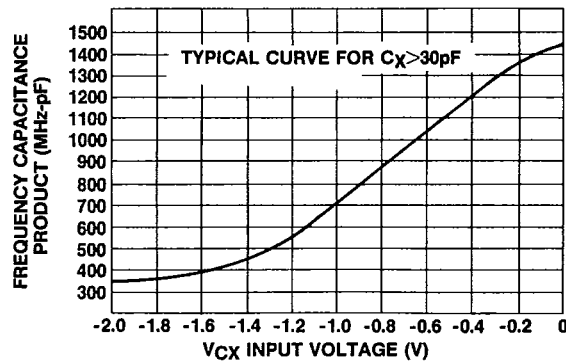
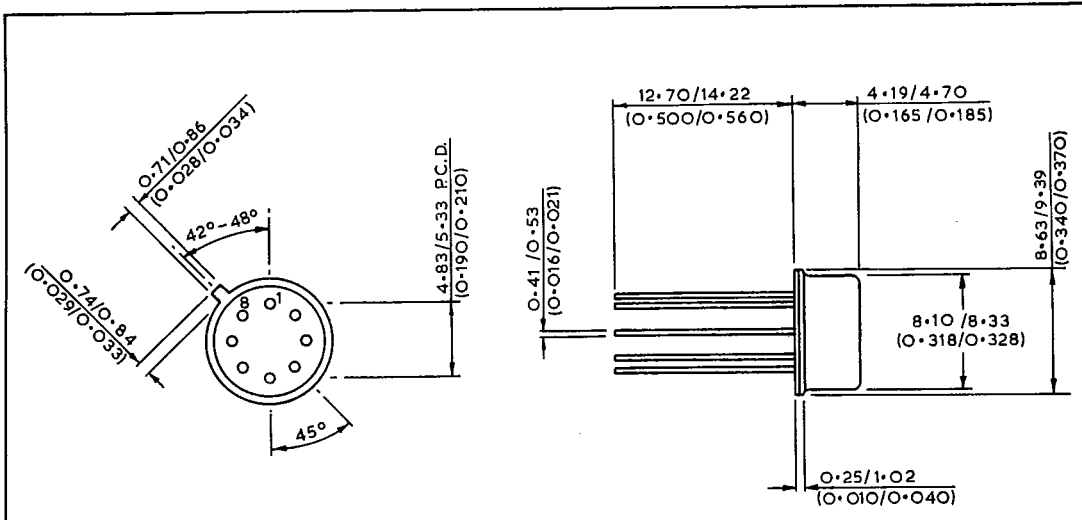

Fig.6 Frequency-capacitance product v. control voltage V_{cx}

T-90-20



NOTE: This package does not have 'standoff' and therefore does not conform fully to MIL-M-38510F case outline A-1.

8-LEAD METAL CAN

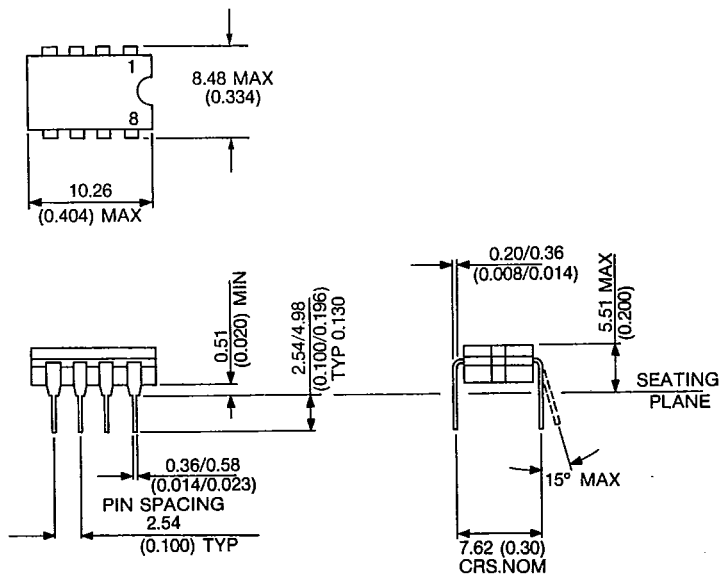

8 LEAD CERAMIC DIL CERDIP - DG8

T-90-20

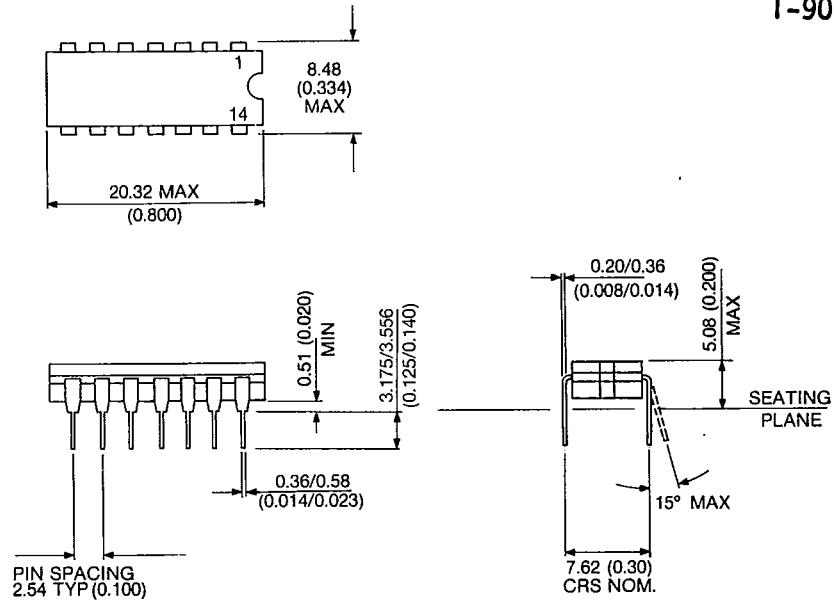

14 LEAD CERAMIC DIL CERDIP - DG14

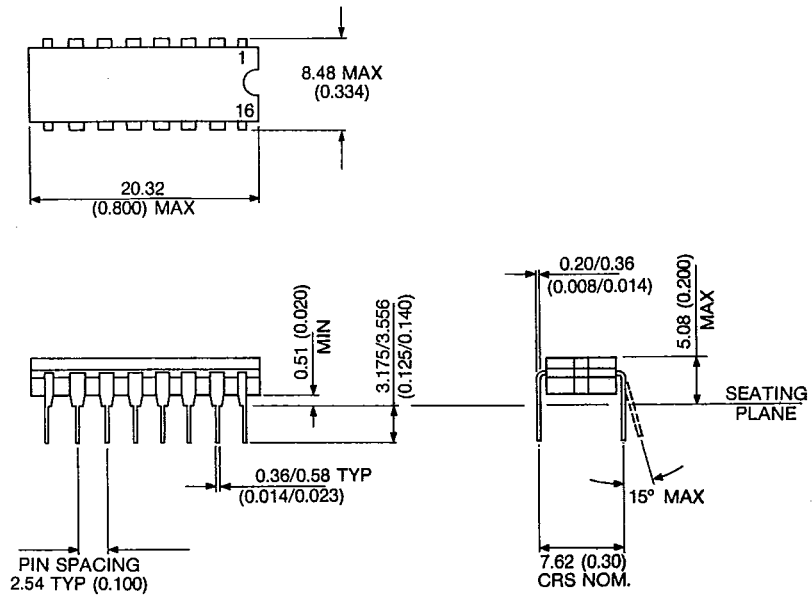

16 LEAD CERAMIC DIL CERDIP - DG16

