

2.5×5 Rectangular Bicolor LED

SML10060 Series

External Dimensions

(Unit: mm)

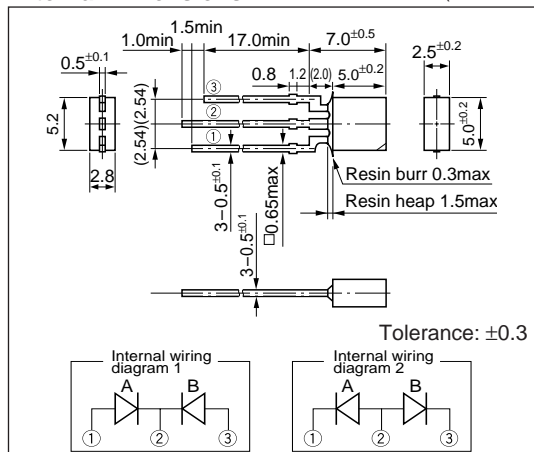

Directivity (Typical)

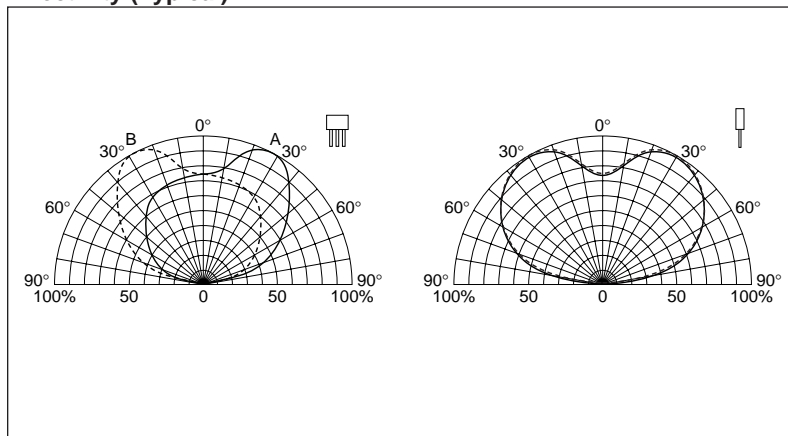

Absolute maximum ratings (Ta=25°C)

Symbol	Unit	Rating	Condition
I _F	mA	30	
ΔI _F	mA/°C	-0.45	Above 25°C
I _{FP}	mA	100	f=1kHz, tw≤100μs
V _R	V	4	
Top	°C	-30 to +85	
Tstg	°C	-30 to +100	

Electrical Optical characteristics (Ta=25°C)

●Common cathode (Internal wiring diagram 1)

Emitting color	Part Number	Lens color	Forward voltage			Reverse current		Intensity		Peak wavelength		Spectrum half width		Chip material
			V _F (V)		Condition I _F (mA)	I _R (μA)	Condition V _R (V)	I _v (mcd)	Condition I _F (mA)	λ _P (nm)	Condition I _F (mA)	Δλ (nm)	Condition I _F (mA)	
			typ	max										
A Red	SML12460C	Clear	1.9	2.5	10	10	4	10	20	630	10	35	10	GaAsP
B Green			2.0	2.5	10	10	4	25	20	560	10	20	10	GaP
A Orange	SML19460C	Clear	1.9	2.5	10	10	4	15	20	587	10	35	10	GaAsP
B Green			2.0	2.5	10	10	4	25	20	560	10	20	10	GaP

●Common anode (Internal wiring diagram 2)

Emitting color	Part Number	Lens color	Forward voltage			Reverse current		Intensity		Peak wavelength		Spectrum half width		Chip material
			V _F (V)		Condition I _F (mA)	I _R (μA)	Condition V _R (V)	I _v (mcd)	Condition I _F (mA)	λ _P (nm)	Condition I _F (mA)	Δλ (nm)	Condition I _F (mA)	
			typ	max										
A High-intensity red	SML16760CN	Clear	1.7	2.2	10	10	4	30	20	660	10	30	10	GaAlAs
B Yellow			2.4	3.0	10	10	4	40	20	570	10	30	10	GaP