

20W TO-263 HIGH POWER SURFACE MOUNT RESISTORS

Features

- Non-Inductive, Small, 20 Watt high power resistor.
- TO-263 surface mount package offering a very low thermal resistance.
- Small thin package for high density PCB installation.
- RoHS compliant.
- Suitable for board mounting with either solder or clip.

Applications

- High frequency emitter resistors in switching power supplies.
- High precision CRT color video amplifiers.
- High frequency snubber and pulse handling circuits.
- Pulse generator load resistors.
- In-rush current protection
- Bleeder Resistors



Specification

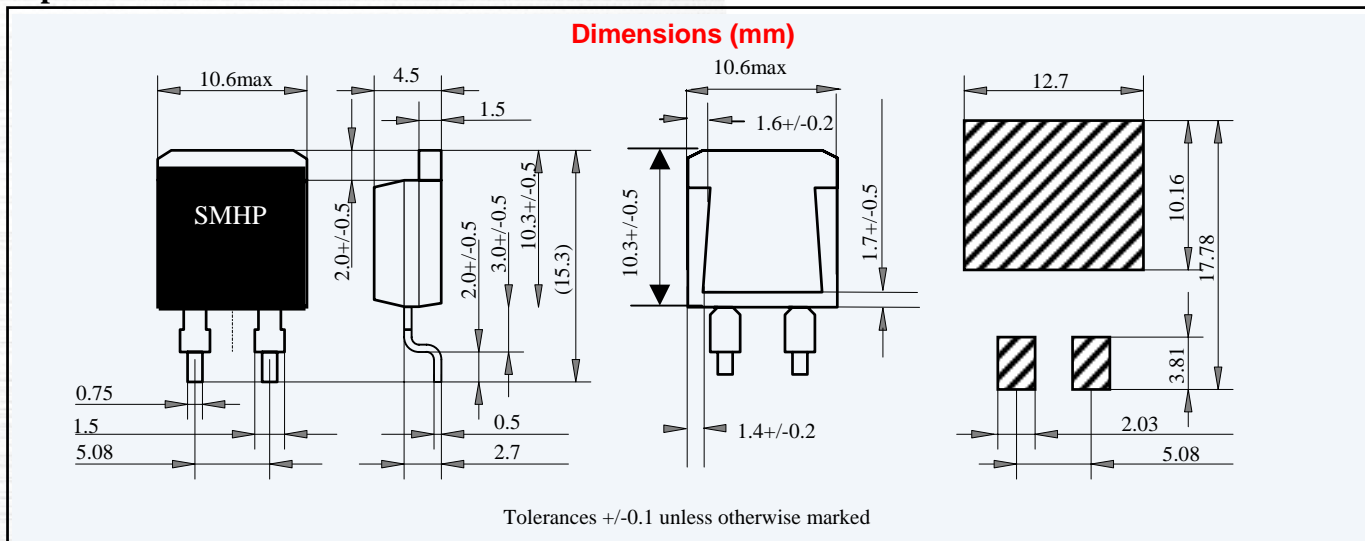

Specifications subject to change without notice

Items	Specification			Test Conditions
Power Rating	20 Watt			-55°C to 25°C flange temperature
Power Rating	2.25 Watt			Without heatsink
Thermal Resistance	3.3°C/W			Resistor hot spot to flange
Resistance Range	0.01-0.09 Ω	0.1-9.1 Ω	10-220 Ω	Up to 51KΩ also available
Nominal Resistance Series	E6	E12	E24	Including 2.5Ω and 5.0 Ω
TCR(ppm/°C)	250	100	50	For -55°C to +155 °C
Tolerance	+/-5%	+/-1% & +/-5%	+/-1%	
Operation Temp. Range	-55°C to +155°C			
Max. Operating Voltage	500V or $\sqrt{P \cdot R}$			
Dielectric Withstanding Voltage.	2000 V DC			60 seconds.
Load Life	ΔR +/- (1.0% + 0.05 Ω)			25°C, 90 min.ON, 30min.OFF, 1000hours.
Humidity	ΔR +/- (1.0% + 0.05 Ω)			40°C, 90-95%RH, DC 0.1W, 1000 hours.
Temp. Cycle	ΔR +/- (0.25% + 0.05 Ω)			-55°C,30 min.,+155°C,30 min., 5cycles
Soldering Heat (Max)	ΔR +/- (0.1%+0.05 Ω)			250+/-5°C, 3seconds,
Solderability	Min. 90% coverage			230+/-5°C, 3seconds.
Insulation Resistance	Over 1,000 Meg Ω			Between terminals and tab.
Vibration	ΔR +/- (0.25% + 0.05 Ω)			

Notes:

1. Electrically isolated metal tab.
2. Contact factory for custom products, non-standard values and tolerances.
3. Current rating: 25A maximum.

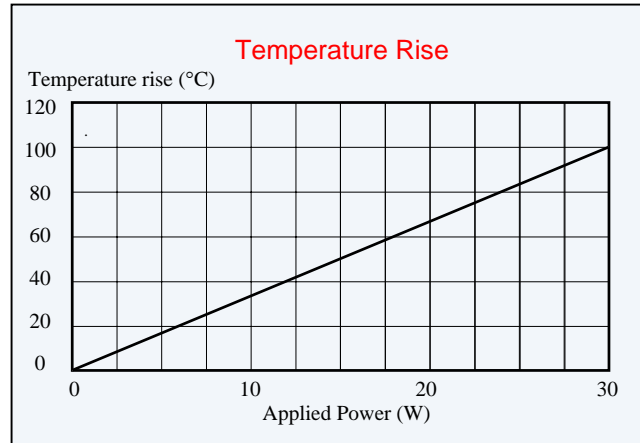
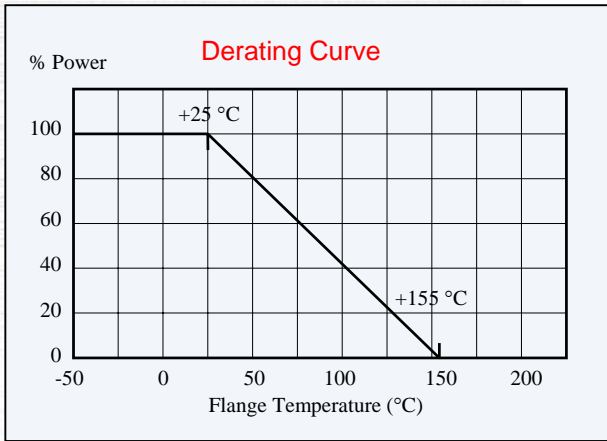

Tape Dimensions and Orientation

Reel Dimension:
 Outer Diameter: 300 mm
 Inner Diameter: 100 mm
 Width: 23.9 mm min. 27.4 mm max
 Quantity: 500pcs/reel

Reel Orientation:
 Units to be orientated with Pins facing Sprocket Holes

FR4 Thermal PCB Characterisation

Pad Dimensions (x,y mm)	P _{90°C, 35µm} (W)
50, 40	4.5
45, 35	4
40, 30	3.5
35, 25	3
20, 10	2

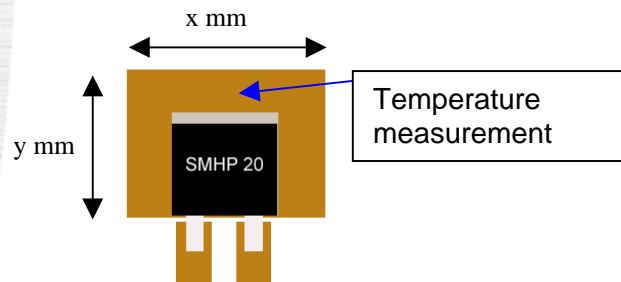

Notes: Characterisation carried out using 35µm PCB copper pad weights, with the temperature of 90°C used as a maximum reference on the PCB. P_{90°C, 35µm} (W) is power when the measurement point reaches 90 °C

Ordering Information

SMHP 20	500	F
Model	Resistance Code	Tolerance
0.1Ω : 0R100	50 Ω : 500 First two digits significant, last digit: number of trailing zeros	J = 5% Tol F = 1% Tol