

OVERVIEW

The SM6781BV is a quick charge control IC for Nickel Metal Hydride (NiMH) and Nickel-Cadmium (NiCd) rechargeable batteries. Quick charging ends in response to negative delta voltage detection ($-\Delta V$) and maximum charging time detection functions. Also, quick charge mode is placed on hold if the battery voltage becomes abnormal, until normal conditions are restored. The SM6781BV requires few external components to realize a high-stability quick charge battery charger.

FEATURES

- Ni-MH/Ni-Cd battery quick charge control
- $-\Delta V$ and maximum charge time cutoffs
- 15min (typ) $-\Delta V$ detection invalid time
- $-4mV$ (typ) $-\Delta V$ detection accuracy
- Inhibit function
- Charge condition LED indicator output (on, pulsed, off)
- Low power dissipation standby mode ($< 1\mu A$)
- 8-pin VSOP package

ORDERING INFORMATION

Device	Package
SM6781BV	8-pin VSOP

PINOUT

(Top view)

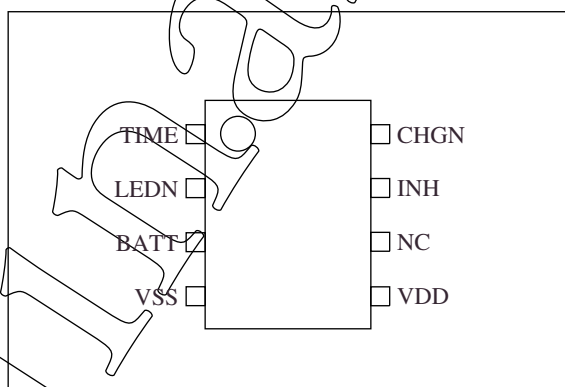

PACKAGE DIMENSIONS

(Unit: mm)

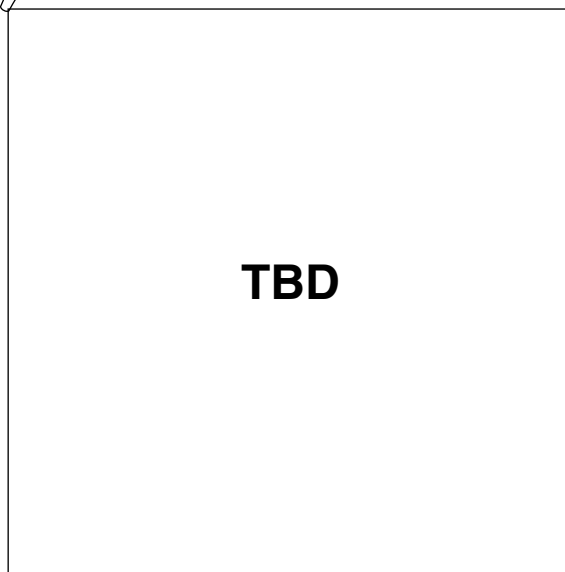

Pre-Release

BLOCK DIAGRAM

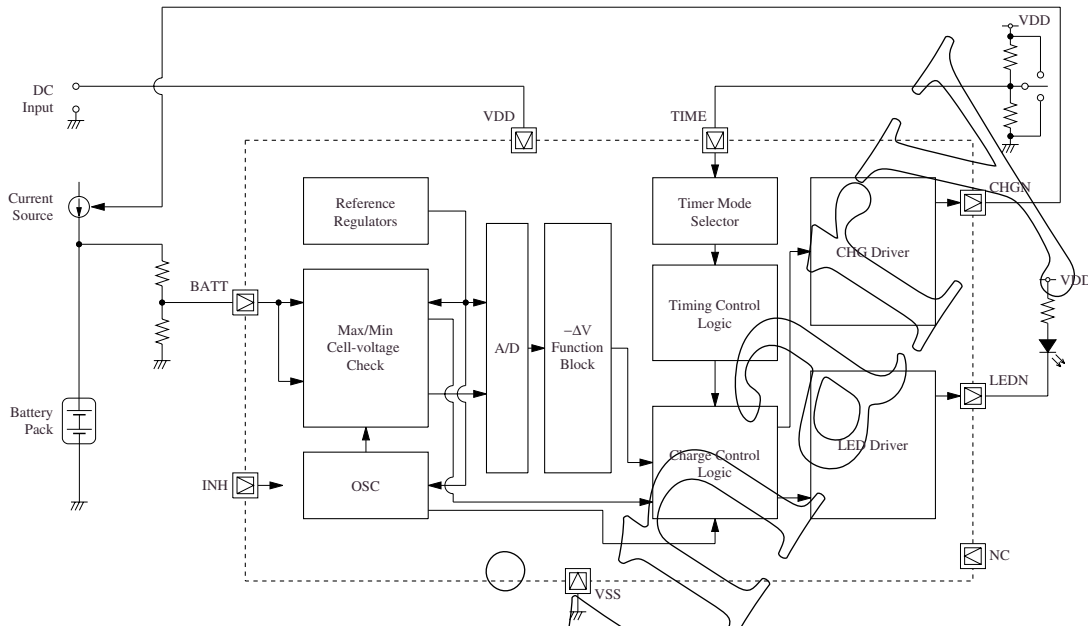

PIN DESCRIPTION

Number	Name	I/O	Description
1	TIME	I	Timer mode select input (3-level). HIGH and LOW levels applied using pull-up and pull-down, respectively. MID-level is applied using a voltage divider resistor network with voltage VDD/2.
2	LEDN	O	Charge status display LED driver output (open-drain output). LOW-level output in quick-charge mode. 1Hz pulse output when abnormal battery voltage is detected during quick charge. High impedance when charging finishes.
3	BATT	I	Battery voltage detector input. Connect a high-impedance resistor voltage divider between the poles of the battery for voltage detection.
4	VSS	-	Ground
5	VDD	-	Supply
6	NC	-	No connection (must be open)
7	INH	I	Inhibit input. Charging operation is stopped when HIGH. Charging recommences with the same charging parameters when INH goes LOW again.
8	CHGN	O	Charge control (open-drain output). High impedance output when charging current is flowing. LOW-level output when charging current stops.

SPECIFICATIONS

Absolute Maximum Ratings

$$V_{SS} = 0V$$

Parameter	Symbol	Condition	Rating	Unit
Supply voltage range	V_{DD}		-0.3 to 7.0	V
Input voltage range	V_{IN}		-0.3 to 7.0	V
Storage temperature range	T_{stg}		-55 to 125	°C
Operating temperature range	T_{opr}		-25 to 85	°C
Power dissipation	P_D		150	mW

DC Characteristics 1

$$V_{DD} = 4.0 \text{ to } 5.5V, V_{SS} = 0V, T_a = 25^\circ C$$

Parameter	Symbol	Condition	Rating	Variation	Unit
Minimum battery voltage	V_{MNV}	$V_{BATT} < V_{MNV}$ charge cutoff or prohibition	0.6	± 0.2	V
Maximum battery voltage	V_{MXV}	$V_{BATT} > V_{MXV}$ charge cutoff or prohibition	2.0	± 0.1	V

DC Characteristics 2

$$V_{DD} = 4.0 \text{ to } 5.5V, V_{SS} = 0V, T_a = 0 \text{ to } 85^\circ C \text{ unless otherwise noted}$$

Parameter	Symbol	Condition	Rating			Unit
			min	typ	max	
VDD supply voltage	V_{DD}		4.0	5.0	5.5	V
BATT input voltage	V_{BATT}		0	-	V_{DD}	V
INH HIGH-level input voltage	V_{IH1}		0.7	-	-	V
INH LOW-level input voltage	V_{IL1}		-	-	0.1	V
TIME HIGH-level input voltage	V_{IH2}		$V_{DD} - 0.5$	-	-	V
TIME MID-level input voltage	V_{IM}		$(V_{DD}/2) - 0.5$	-	$(V_{DD}/2) + 0.5$	V
TIME LOW-level input voltage	V_{IL2}		-	-	0.5	V
BATT $-\Delta V$ detection voltage range	V_{DET}		1	-	2	V
LEDN output pulse frequency	f_{LED}		-	1	-	Hz
BATT standby voltage	V_{STB}		$V_{DD} - 1.5$	-	$V_{DD} - 0.5$	V
VDD current consumption	I_{DD}	$V_{DD} = 5V$, no load	-	-	0.5	mA
VDD standby current	I_{STB}	$V_{DD} = 5V$, $V_{BATT} = V_{DD}$, no load	-	-	1	μA
LEDN, CHGN sink current	I_{OL}	$V_{OL} = V_{SS} + 0.8V$	10	-	-	mA
INH, TIME input leakage current	I_L	$V_{INH} = V_{TIME} = V_{SS} \text{ to } V_{DD}$	-	-	± 1	μA
LEDN, CHGN output leakage current	I_{OZ}		-5	-	-	μA

Maximum Quick Charging Time $V_{DD} = 5V, T_a = 25^\circ C$

TIME pin	min	typ	max	Unit
HIGH	192	240	288	min
MIDDLE	96	120	144	min
LOW	64	80	96	min

– ΔV Detection Voltage $V_{DD} = 5V, T_a = 25^\circ C$

	min	typ	max	Unit
– ΔV detection voltage	–	–4	–	mV

– ΔV detection prohibit time $V_{DD} = 5V, T_a = 25^\circ C$

	min	typ	max	Unit
– ΔV detection prohibit time	720	900	1080	sec

Preliminary

FUNCTIONAL DESCRIPTION

Charging Flowchart

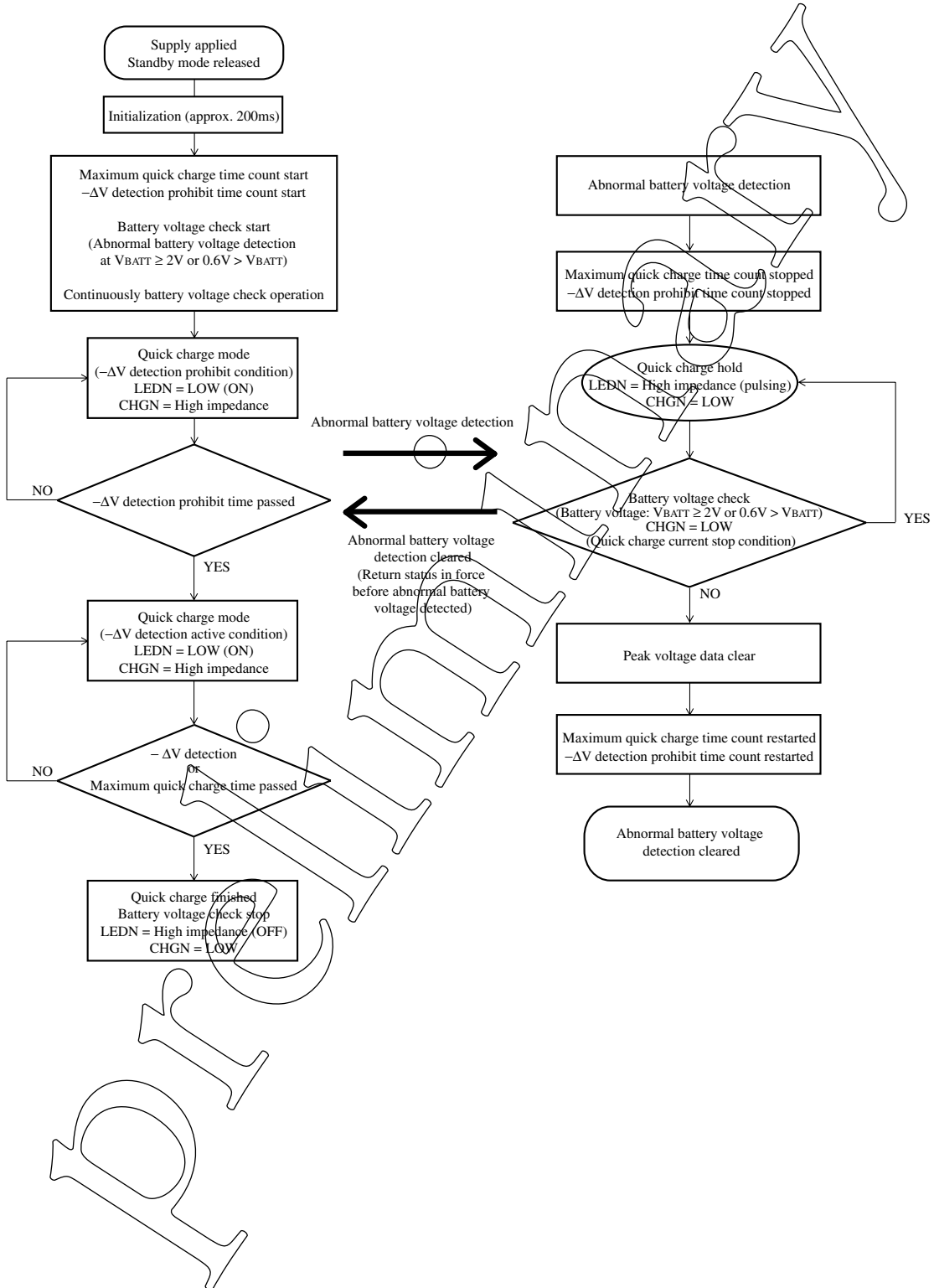

Initialization

The SM6781BV charging operation commences when power is applied or when a battery is inserted (standby mode released). Approximately 200ms are required when operation starts to initialize all internal circuits. When initialization finishes, the charging mode is determined by the BATT input voltage and the timer mode.

Battery Voltage Check

When the BATT input voltage is outside the permitted range, quick charge stops. At this point, the maximum quick charge time count and $-\Delta V$ prohibit time counters also stop. When the BATT input voltage comes back within the permitted range, quick charge and timer stop conditions are released. When quick charge mode is restarted, the saved peak voltage data is reset (cleared to 0V).

$-\Delta V$ Detection Prohibit Time

$-\Delta V$ detection is not performed for approximately 15 minutes from when quick charge commences (quick charge cumulative time).

CHGN Output

CHGN becomes high impedance during quick charge. CHGN goes LOW when quick charge mode finishes or when abnormal battery voltage is detected.

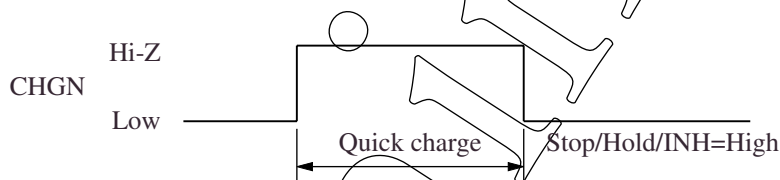

Figure 1. CHGN state

LEDN Output

LEDN is LOW during quick charge (LED is ON), and high impedance after quick charge finishes (LED is OFF). When an abnormal battery voltage is detected before quick charge finishes, a pulse of approximately 1Hz is output (LED flashes). Also, a 1Hz pulse is output when INH is HIGH.

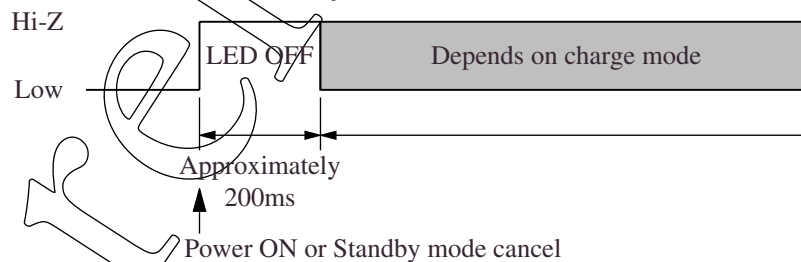

Figure 2. LEDN output

Quick Charge Termination

Quick charge finishes when either $-\Delta V$ voltage is detected or the maximum charging time has elapsed.

– ΔV Detection Function

A – ΔV condition is detected when the BATT voltage (V_{BATT}) falls 4mV (typ) or more below the peak battery voltage, at which point the battery is deemed to be fully charged and quick charge finishes (valid for $1V < V_{BATT} < 2V$).

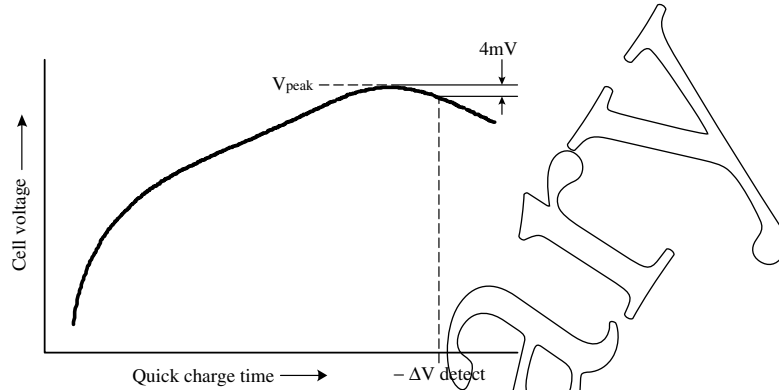

Figure 3. Battery voltage change

– ΔV Detection A/D Converter

The A/D converter employs double integration A/D conversion, and converts samples taken approximately every 1.17 seconds.

– ΔV Detection Timing

The – ΔV detection and peak voltage detection are determined by the average value of 16 A/D converted samples. Consequently, – ΔV detection timing occurs approximately every 18 seconds (16-sample length).

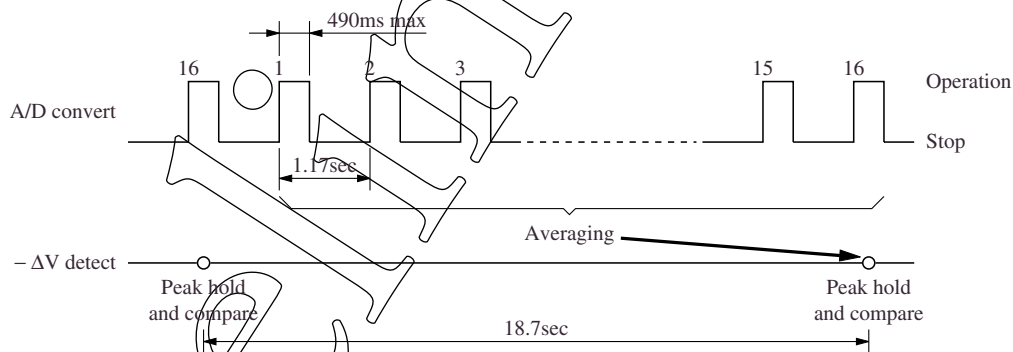

Figure 4. – ΔV detection and A/D convert

Standby Mode

When the BATT input voltage exceeds the standby voltage V_{STB} , the device enters standby mode.

In this mode, the maximum charging time timer, – ΔV detection prohibit timer, and peak voltage data are all reset to zero. At this time, the CHGN and LEDN outputs both become high impedance.

Charge Inhibit (INH)

When INH goes HIGH, charge mode operation stops. While INH is HIGH, the internal timer stops, CHGN goes LOW and LEDN outputs 1Hz pulse (LEDN flashes). When INH goes LOW, the SM6781BV is restored to the previous state and the internal timer restarts. If INH is connected to temperature switch (NPC SM6611), it realizes simple temperature control.

BATT Input

The voltage applied to the BATT input, used for battery voltage detection, is a voltage potential, derived by a voltage divider resistor network (100kΩ or higher recommended) or other means, that represents the voltage of a single battery cell during charging. If a single cell only is under charge, a current limiting resistor (100kΩ or higher is recommended) should be connected between the battery and BATT input.

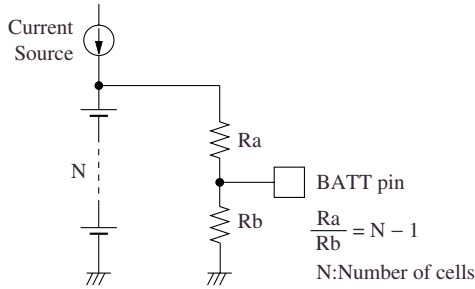

Figure 5. BATT connection example (multiple)

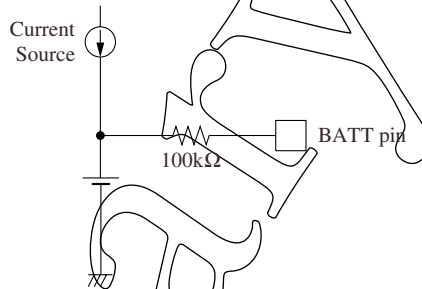
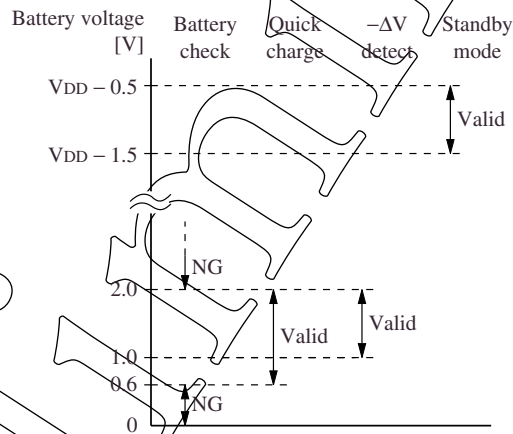

Figure 6. BATT connection example (single)

Operating Mode vs. BATT Input Voltage



Charging Operating Status

Charging status	Conditions		CHGN output	LEDN output	Internal timer
	INH	Battery check OK			
Quick charge	LOW	Yes	High impedance	LOW (ON)	Count
Quick charge hold	LOW	No	LOW	1Hz (pulsing)	Hold
Quick charge inhibit	HIGH	—	LOW	1Hz (pulsing)	Hold
Quick charge finish	LOW	Yes	LOW	High impedance (OFF)	Reset
Standby	—	—	High impedance	High impedance (OFF)	Reset

TYPICAL APPLICATION CIRCUIT

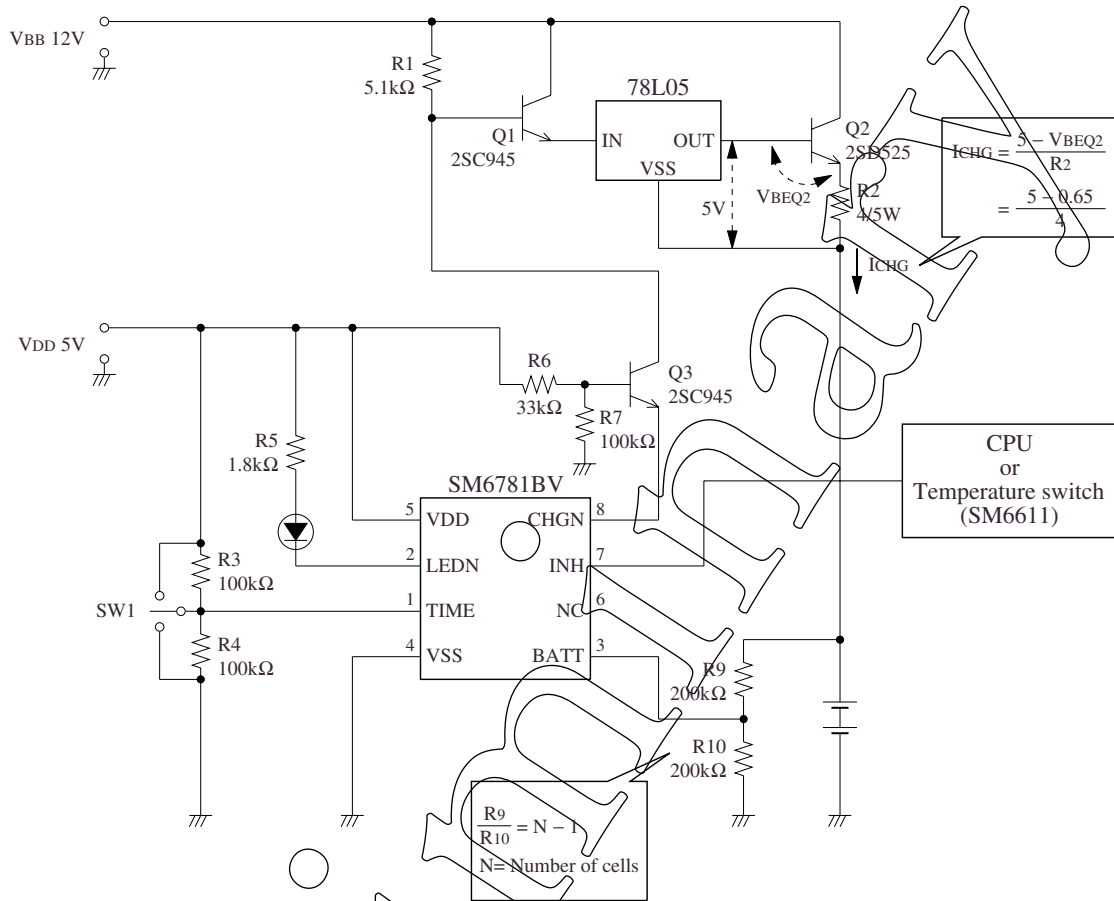

Note that the above circuit is an example circuit to demonstrate the connections for device functions. Battery charger operation is not guaranteed.

PRELIMINARY

Preliminary

NIPPON PRECISION CIRCUITS INC. reserves the right to make changes to the products described in this data sheet in order to improve the design or performance and to supply the best possible products. Nippon Precision Circuits Inc. assumes no responsibility for the use of any circuits shown in this data sheet, conveys no license under any patent or other rights, and makes no claim that the circuits are free from patent infringement. Applications for any devices shown in this data sheet are for illustration only and Nippon Precision Circuits Inc. makes no claim or warranty that such applications will be suitable for the use specified without further testing or modification. The products described in this data sheet are not intended to use for the apparatus which influence human lives due to the failure or malfunction of the products. Customers are requested to comply with applicable laws and regulations in effect now and hereinafter, including compliance with export controls on the distribution or dissemination of the products. Customers shall not export, directly or indirectly, any products without first obtaining required licenses and approvals from appropriate government agencies.

NPC
NIPPON PRECISION CIRCUITS INC.

NIPPON PRECISION CIRCUITS INC.

4-3, Fukuzumi 2-chome
Koto-ku, Tokyo 135-8430, Japan
Telephone: +81-3-3642-6661
Facsimile: +81-3-3642-6698
<http://www.npc.co.jp/>
Email: sales@npc.co.jp

NP0026AE 2001.01