



DC COMPONENTS CO., LTD.

RECTIFIER SPECIALISTS

**SM4933
THRU
SM4937**

TECHNICAL SPECIFICATIONS OF SURFACE MOUNT FAST RECOVERY RECTIFIER

VOLTAGE RANGE - 50 to 600 Volts

CURRENT -1.0 Ampere

FEATURES

- * Ideal for surface mounted applications
- * Low leakage current
- * Fast switching
- * Glass passivated junction

MECHANICAL DATA

- * Case: Molded plastic
- * Epoxy: UL 94V-0 rate flame retardant
- * Terminals: Solder plated solderable per MIL-STD-202E, Method 208 guaranteed
- * Polarity: Color band denotes cathode end
- * Mounting position: Any
- * Weight: 0.12 gram

MAXIMUM RATINGS AND ELECTRICAL CHARACTERISTICS

Ratings at 25 °C ambient temperature unless otherwise specified.
Single phase, half wave, 60 Hz, resistive or inductive load.
For capacitive load, derate current by 20%.



SM-1(DO-213AB)

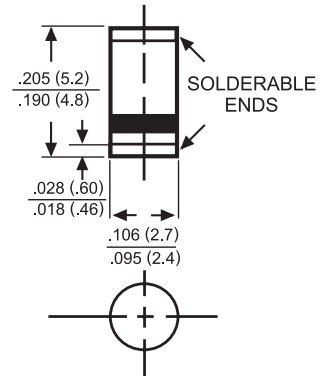

Dimensions in inches and (millimeters)

	SYMBOL	SM4933	SM4934	SM4935	SM4936	SM4937	UNITS
Maximum Recurrent Peak Reverse Voltage	VRRM	50	100	200	400	600	Volts
Maximum RMS Voltage	VRMS	35	70	140	280	420	Volts
Maximum DC Blocking Voltage	Vdc	50	100	200	400	600	Volts
Maximum Average Forward Rectified Current TA = 55°C	Io	1.0					Amps
Peak Forward Surge Current IFM (surge): 8.3 ms single half sine-wave superimposed on rated load (JEDEC Method)	IFSM	30					Amps
Maximum Forward Voltage at 1.0A DC	VF	1.3					Volts
Maximum DC Reverse Current at @TA = 25°C	IR	5.0					uAmps
Rated DC Blocking Voltage @TA = 125°C		100					
Maximum Reverse Recovery Time (Note 3)	trr	150				250	nSec
Maximum Thermal Resistance (Note 2)	RθJL	30					°C/W
Typical Junction Capacitance (Note 1)	Cj	15					pF
Operating and Storage Temperature Range	TJ, TSTG	-65 to + 175					°C

- NOTES : 1. Measured at 1.0 MHz and applied reverse voltage of 4.0VDC
 2. Thermal resistance (Junction to Ambient) .24in² (6.0mm²) copper pads to each terminal.
 3. Test Conditions: IF = 0.5A, IR=1.0A, IRR=0.25A

RATING AND CHARACTERISTIC CURVES (SM4933 THRU SM4937)

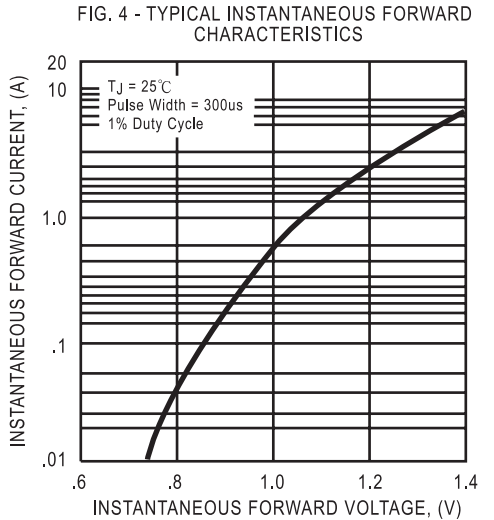
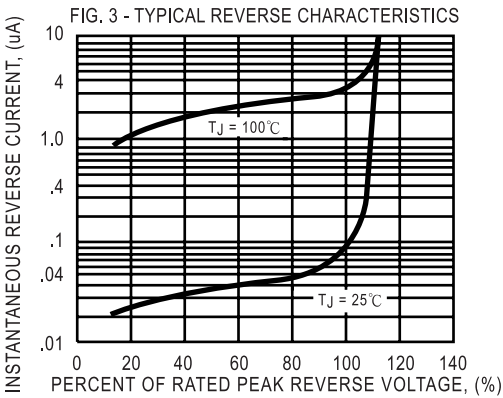
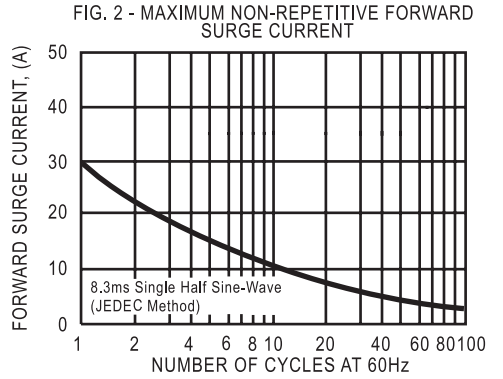
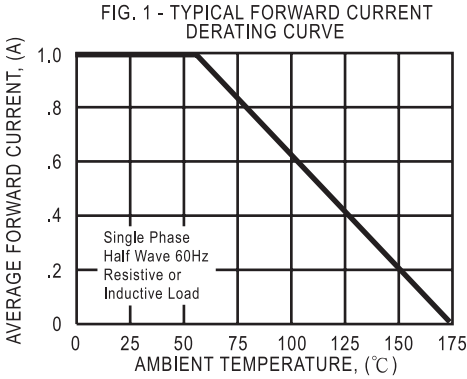

FIG. 5 - TEST CIRCUIT DIAGRAM AND REVERSE RECOVERY TIME CHARACTERISTIC

