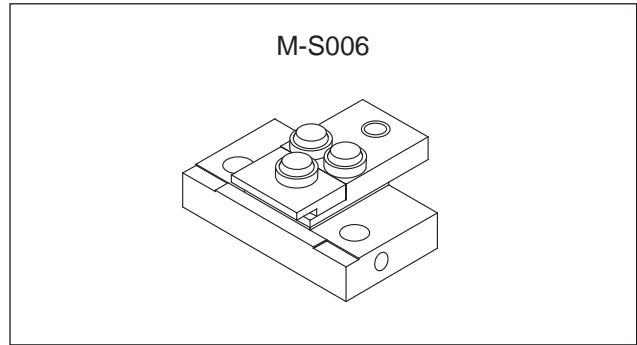

20W Array Laser Diode*Preliminary***Description**

The SLD402S is a high power laser diode with an array structure, which achieves 20W high power.

Features

- High power
Recommended optical power output: $P_o = 20W$
- Array structure
- Open package

**Applications**

Solid state laser excitation

Structure

GaAIAs quantum well structure laser diode

Operating Lifetime

MTTF 10,000H (effective value) at $P_o = 20W$, $T_c = 25^\circ C$

Absolute Maximum Ratings ($T_c = 25^\circ C$)

- | | | | |
|------------------------|-----------|----|---|
| • Optical power output | P_o | 22 | W |
| • Reverse voltage | V_{RLD} | 2 | V |

Warranty

This warranty period shall be 90 days after receipt of the product or 1,000 hours operation time whichever is shorter.

Sony Quality Assurance Department shall analyze any product that fails during said warranty period, and if the analysis results show that the product failed due to material or manufacturing defects on the part of Sony, the product shall be replaced free of charge.

Laser diodes naturally have differing lifetimes which follow a Weibull distribution.

Special warranties are also available.

Sony reserves the right to change products and specifications without prior notice. This information does not convey any license by any implication or otherwise under any patents or other right. Application circuits shown, if any, are typical examples illustrating the operation of the devices. Sony cannot assume responsibility for any problems arising out of the use of these circuits.

Optical and Electrical Characteristics

(T_c = 25°C)

Item	Symbol	Conditions	Min.	Typ.	Max.	Unit	
Threshold current	I _{th}			6	15	A	
Operating current	I _{op}	P _o = 20W		25	30	A	
Operating voltage	V _{op}	P _o = 20W		1.9	3.0	V	
Wavelength	λ _P	P _o = 20W	790		840	nm	
Radiation angle	Perpendicular	θ _⊥	P _o = 20W		33	40	degree
	Parallel	θ _{//}	P _o = 20W		8	15	degree
Positional accuracy	Position	ΔX, ΔY	P _o = 20W			±300	μm
	Angle	Δφ _⊥				±5	degree
		Δφ _{//}				±4	degree
Differential efficiency	η _D	P _o = 20W	0.5	1.0	1.5	W/A	

Handling Precautions

Eye protection against laser beams

The optical output of laser diodes ranges from several mW to 3W. However the optical power density of the laser beam at the diode chip reaches 1MW/cm². Unlike gas lasers, since laser diode beams are divergent, uncollimated laser diode beams are fairly safe at a laser diode. For observing laser beams, ALWAYS use safety goggles that block infrared rays. Usage of IR scopes, IR cameras and fluorescent plates is also recommended for monitoring laser beams safely.

In addition, the laser diode array of this product is not protected by window glass or other covering (open package product), so special care is necessary when handling.

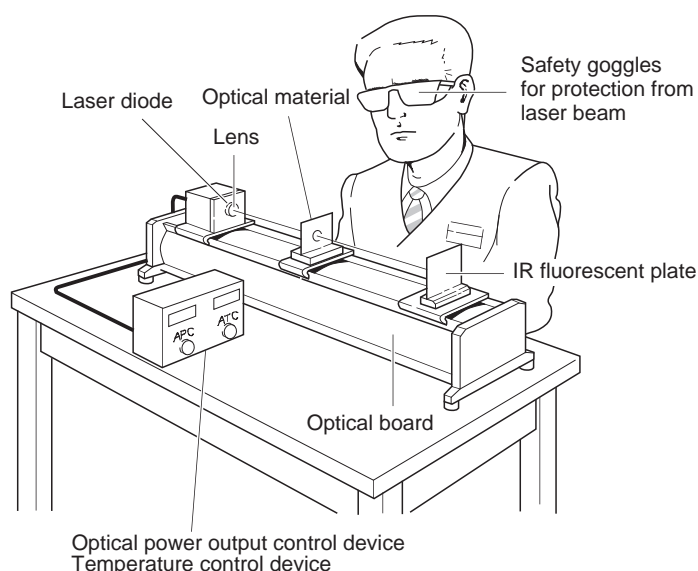

Package Outline

Unit: mm

M-S006

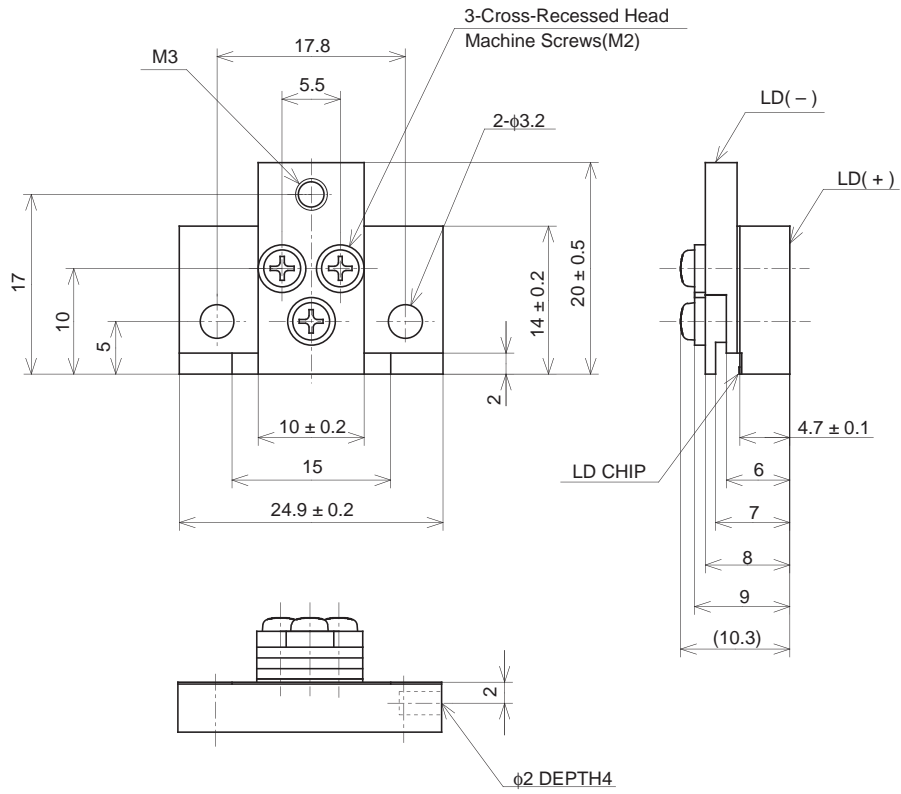

SONY CODE	M-S006
EIAJ CODE	_____
JEDEC CODE	_____

PACKAGE WEIGHT	18.36g
----------------	--------