

**Description**

- The SL1027P is a monolithic integrated circuit consisting of two independent preamplifier with two built-in ALC, and it has quick stabilization during power supply input.

**Features**

- High voltage gain
- Excellent channel separation
- Low noise
- Direct motor drive obtained through SEPP output stage.
- Good ALC channel balance
- Operating supply voltage range :  $V_{CC} = 5V \sim 13V$
- Load resistance :  $R_L > 680\Omega$

**Application**

- Stereo radio cassettes

**Ordering Information**

Type NO.	Marking	Package Code
SL1027P	SL1027	DIP14

**Outline Dimensions**

**unit : mm**

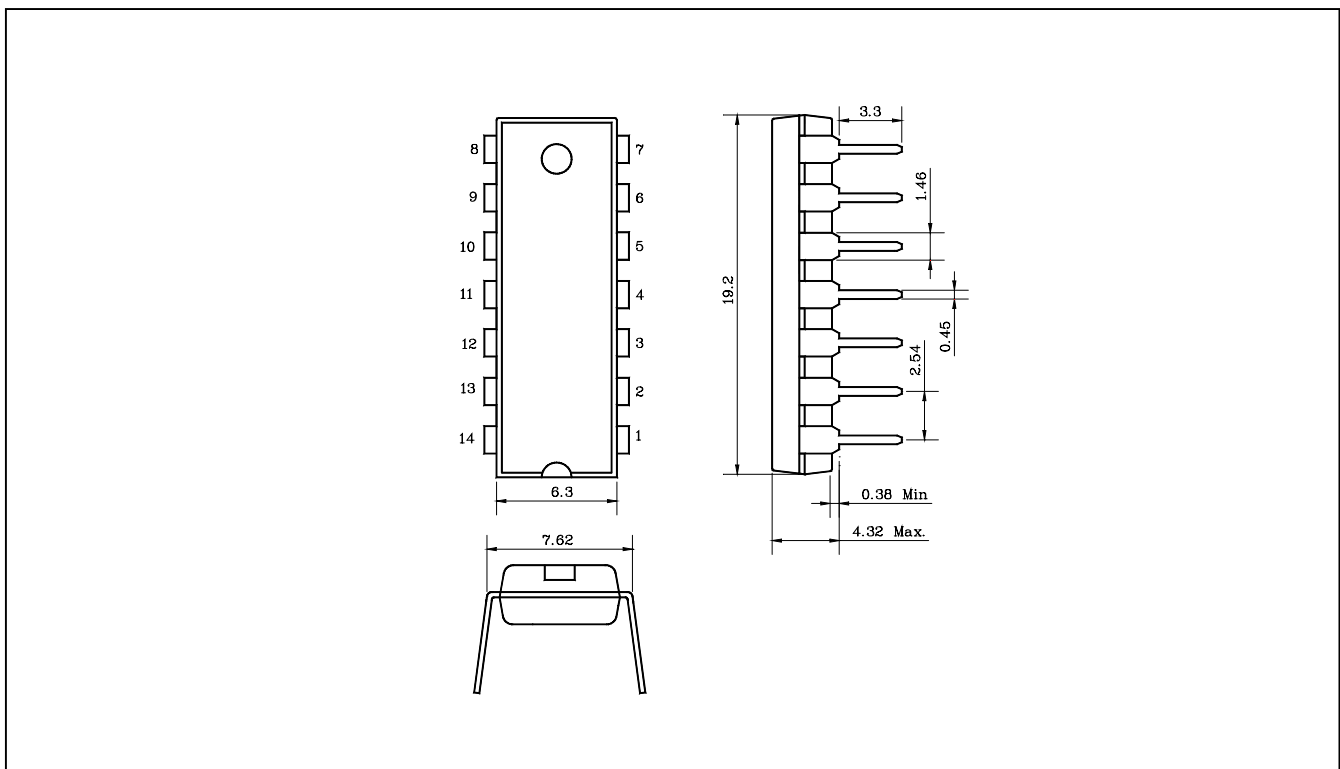

**Maximum Ratings** ( $T_a = 25^\circ\text{C}$ )

Characteristics	Symbol	Rating	Unit
Supply Voltage	$V_{CC}$	14	V
Power Dissipation	$P_D$	600	mW
Operating Temperature	$T_{opr}$	- 25 ~ + 75	$^\circ\text{C}$
Storage Temperature	$T_{stg}$	- 40 ~ + 125	$^\circ\text{C}$

**Electrical Characteristics**(Unless otherwise specified,  $T_a=25^\circ\text{C}$ ,  $V_{CC}=5\text{V}$ ,  $f=1\text{KHz}$ ,  $R_L = 10\text{K}\Omega$  (PLAY),  $R_L = 680\Omega$  (REC))

Characteristics	Symbol	Test Condition	Min.	Typ.	Max.	Unit
Quiescent Supply Current	$I_{CCQ}$	-	-	4.5	10	mA
Open-loop Voltage Gain	$G_{VO}$	-	-	85	-	dB
Closed-loop Voltage Gain	$G_V$	PLAY	-	40	-	dB
		REC	-	58	-	dB
Maximum Output Voltage	$V_{OM}$	THD = 1%, PLAY	0.9	1.2	-	V
Total Harmonic Distortion	THD	$V_O = 0.5\text{V}$ , PLAY	-	0.1	1	%
Input Resistance	$R_{IN}$	-	21	30	-	$\text{K}\Omega$
Equivalent Input Noise Voltage	$V_{NI}$	B.P.F = 20Hz ~ 20KHz $R_g = 2.2\text{k}\Omega$ , PLAY	-	1	2	$\mu\text{V}$
Channel Separation	$CH_{SEP}$	$R_g=2.2\text{k}\Omega$ $V_O= 0\text{dBm}$ ,PLAY	40	50	-	dB
ALC Channel Balance	ACB	$V_{IN}=-20\text{dBm}$ ,REC.	-	0	2	dB
ALC Width	AW	$V_{IN}=-60\text{dBm}$ ,REC.	35	45	-	dB
ALC Distortion	AD	$V_{IN}=-20\text{dBm}$ ,REC.	-	0.5	2	%

Block Diagram

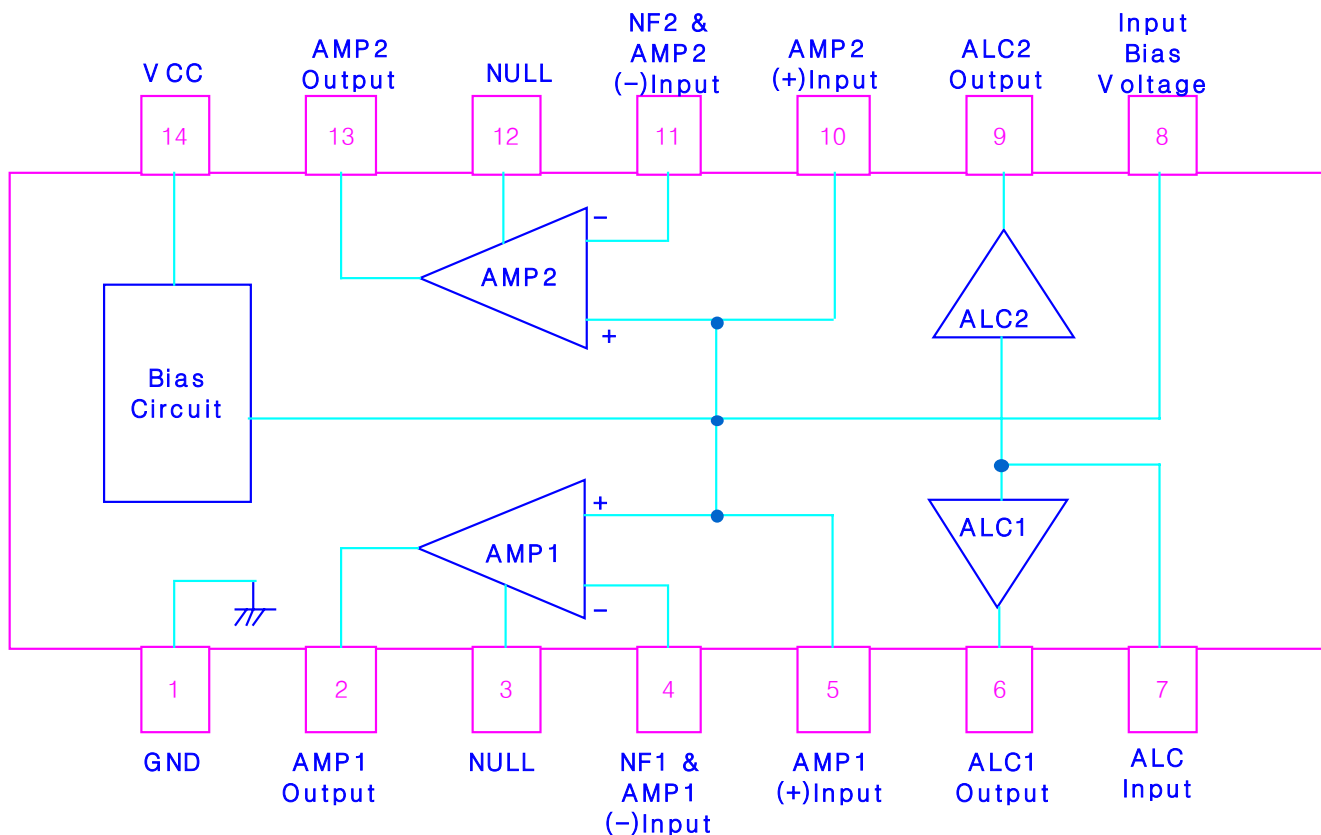

Test Circuit

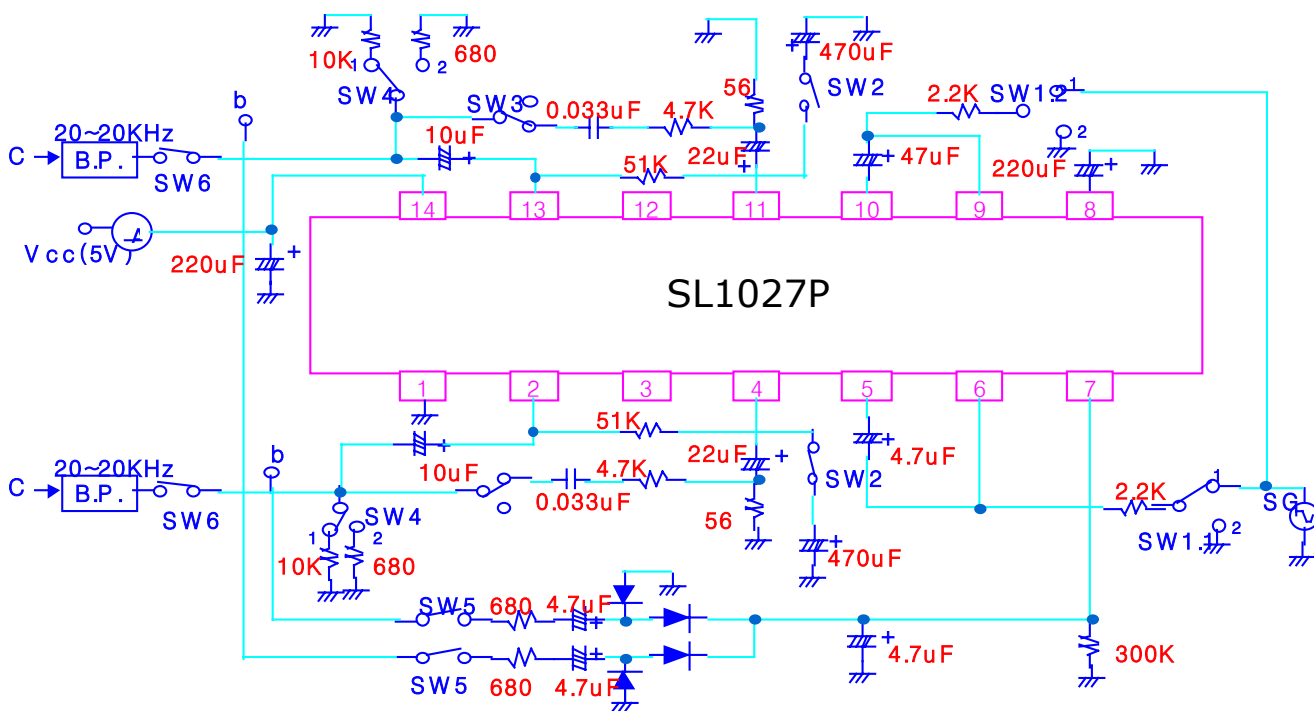

## Test Method

Symbol	Switch Position						Measurement Location	Test Method
	SW 1	SW 2	SW 3	SW 4	SW 5	SW 6		
$I_{CCO}$	2	OFF	OFF	1	OFF	OFF	-	Read ammeter
$G_{VO}$	1	ON	OFF	1	OFF	OFF	a, b	$G_{VO} = 20\log(V_O / V_{IN})$ [dB]
$G_V$	1	OFF	ON	1	OFF	OFF	a, b	$G_V = 20\log(V_O / V_{IN})$ [dB]
$V_{OM}$	1	OFF	ON	1	OFF	OFF	b	Measure output voltage( $V_O$ ) at THD=1%
THD	1	OFF	ON	1	OFF	OFF	b	Measure distortion factor at $V_O=0.5V$
$CH_{SEP}$	SW1-1 1→2 SW1-2 2→1	OFF	ON	1	OFF	OFF	b	Measure crosstalk of amp 1,2 at output voltage $V_O = 0dBm$
$V_{NI}$	2	OFF	ON	1	OFF	ON	c	Convert output noise voltage at 1KHz gain when $R_g = 2.2K\Omega$
AW	1	OFF	OFF	2	ON	OFF	b	Input voltage range from when input voltage $V_{IN} = -60dBm$ until output voltage $V_O$ goes up 3dB
ACB	1	OFF	OFF	2	ON	OFF	b	Output voltage $V_O$ level difference of amp 1,2 when input voltage $V_{IN} = -20dBm$ is applied.
AD	1	OFF	OFF	2	ON	OFF	b	Measure distortion factor when input voltage $V_{IN} = -20dBm$ is applied.

## Information of Operating

### 1. ALC Circuit

The ALC circuit is consist of Q1, Q2 and some external components. The output level of amplifier is rectified by external circuits and this rectified DC level is applied to the ALC input terminal(Pin 7).

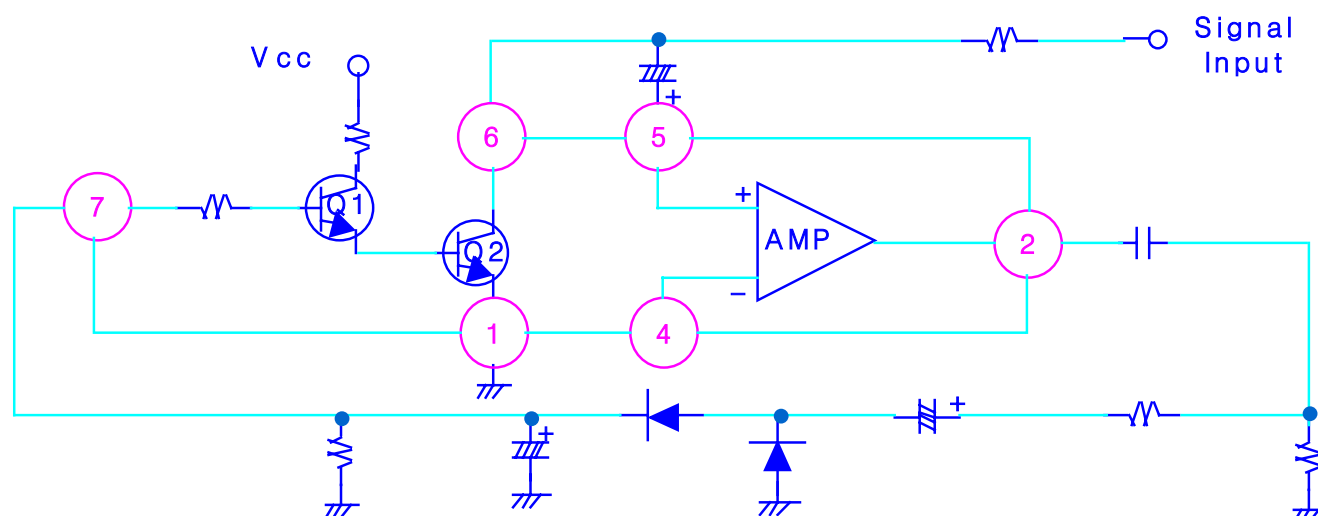

2. Closed-loop Gain (f=1kHz)

- Closed loop voltage gain  
 $G_v = 20 \log(Z1/Z3)$  (dB)
- Playback amplifier gain  
 $G_v = 20 \log(R1/R3)$  (dB)  
 in low frequency  
 $G_v = 20 \log(Z1/Z3)$  (dB)  
 in high frequency
- Recording amplifier gain  
 $G_v = 20 \log(R1/R3)$  (dB)

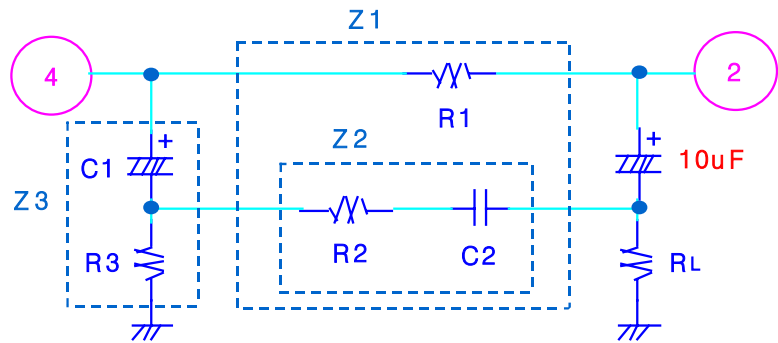

3. Oscillation

When the closed-loop gain of amplifier is lowered, oscillation with occur. So the circuit should be compensated by connecting of 10pF between pin 3 and pin 2, and 0.03  $\mu$ F in series with 10  $\Omega$  to the load end.

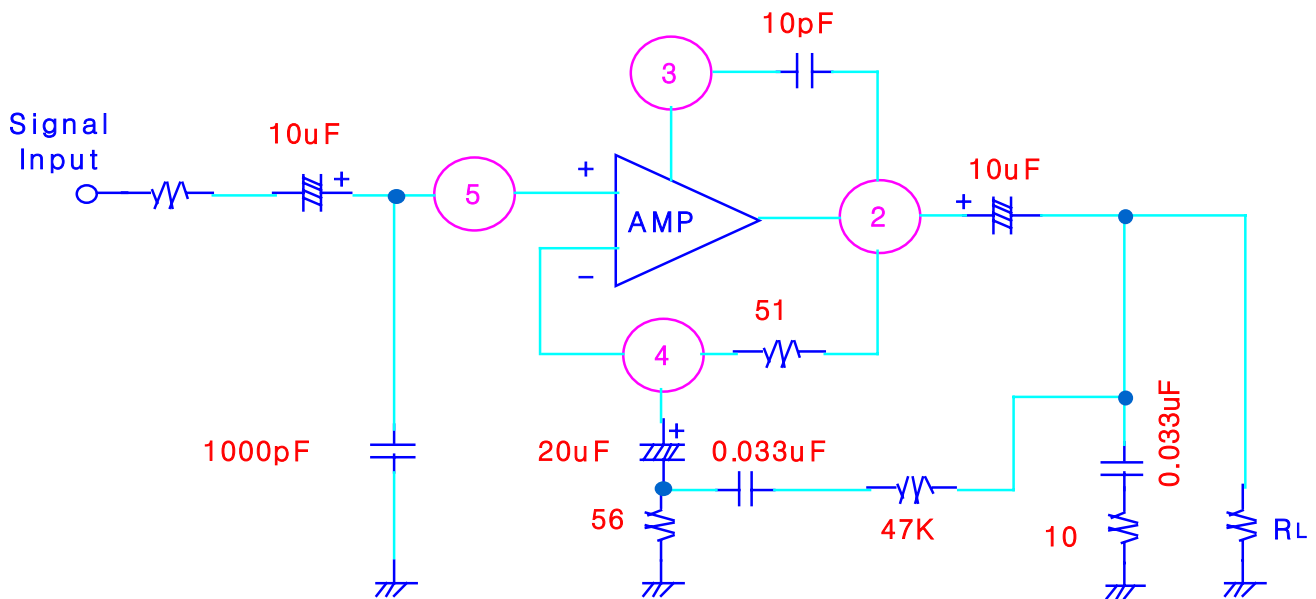

Typical Performance Characteristics

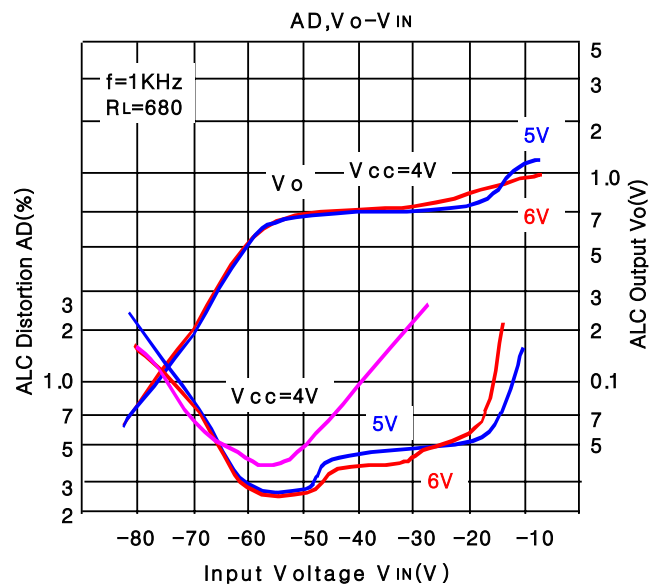
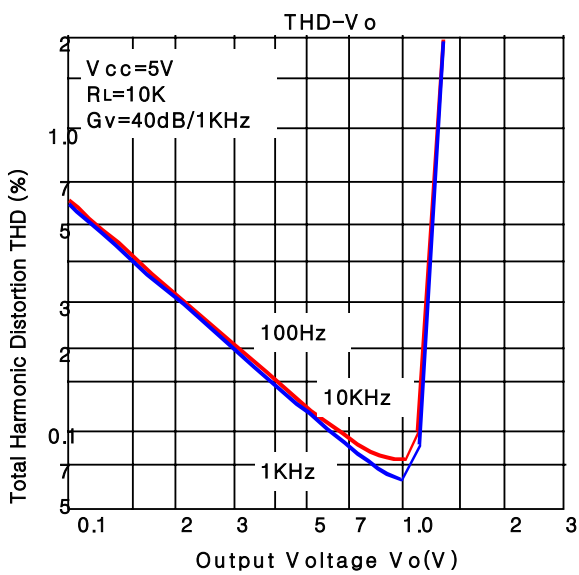
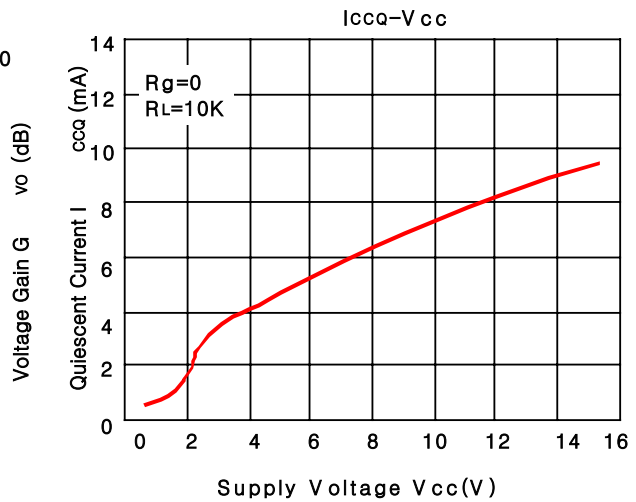
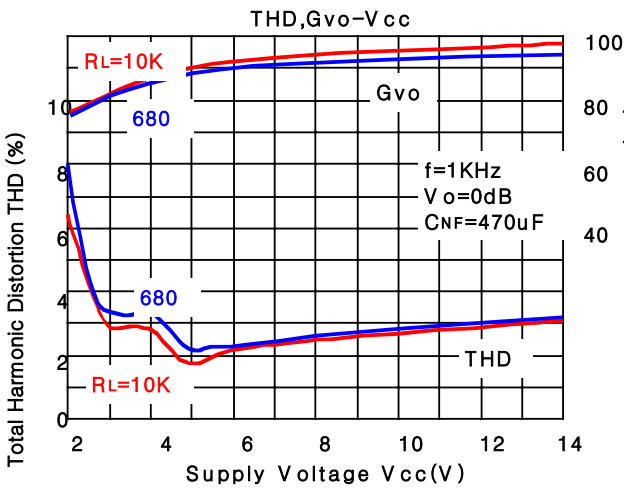
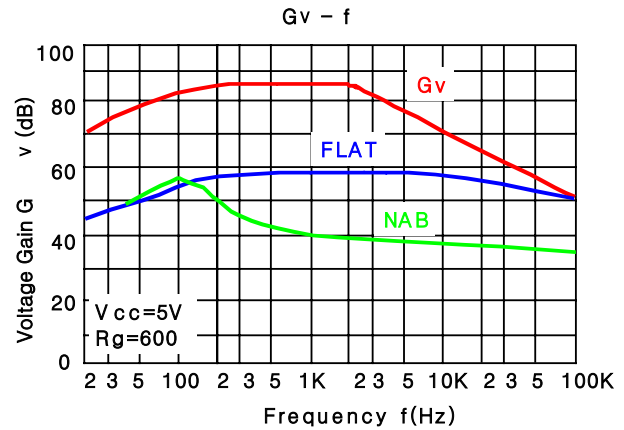
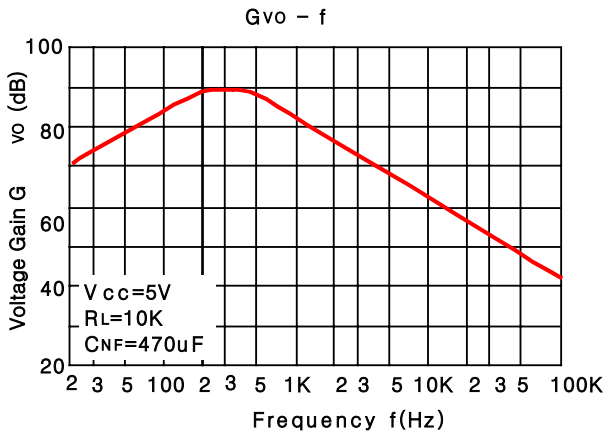

Application Circuit

