

**Applications**

- Gigabit-Ethernet systems, test equipment and modules
- OC-24 fibre optic modules and line termination
- Fibre Channel optical systems

**Features**

- Single +3.3 V power supply
- Power dissipation = 110 mW (typ)
- Input noise current = 180 nA rms when used with a 0.7 pF detector
- Transimpedance gain = 4.0 k $\Omega$  into a 50  $\Omega$  load (differential)
- On-chip automatic gain control gives input current overload of 2.6 mA pk and max output voltage swing of 300 mV pk-pk
- Differential 50  $\Omega$  outputs
- Bandwidth (-3 dB) = 1.2 GHz
- Wide data rate range = 50 Mb/s to 1.25 Gb/s
- Constant photodiode reverse bias voltage = 1.5 V (anode to input, cathode to VCC)
- Minimal external components, supply decoupling only
- Operating junction temperature range = -40 $^{\circ}$ C to +125 $^{\circ}$ C

**Product Description**

SiGe Semiconductor offers a portfolio of optical networking ICs for use in high-performance optical transmitter and receiver functions, from 155 Mb/s up to 12.5 Gb/s.

SiGe Semiconductor's SE1020W is a fully integrated, silicon bipolar transimpedance amplifier; providing wideband, low noise preamplification of signal current from a photodetector. It features differential outputs and incorporates an automatic gain control mechanism to increase dynamic range, allowing input signals up to 2.6 mA peak. A decoupling capacitor on the supply is the only external circuitry required. A system block diagram is shown after the functional description, on page 3.

**Ordering Information**

Type	Package	Remark
SE1020W	Bare Die	None

**Functional Block Diagram**

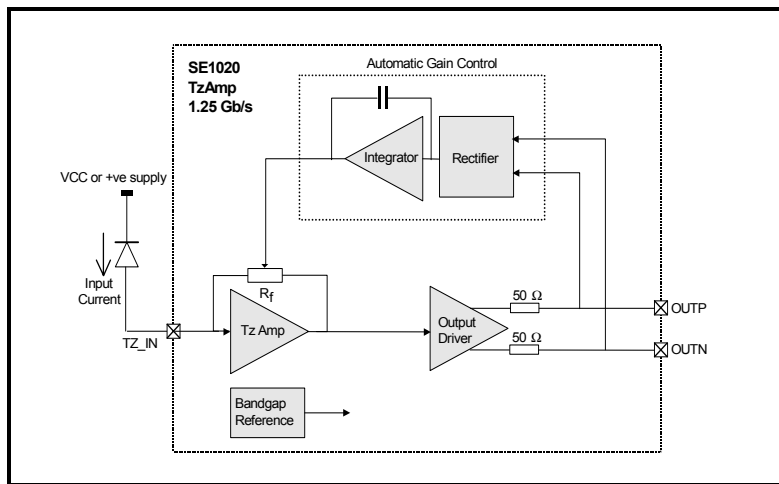

**Bondpad Diagram**

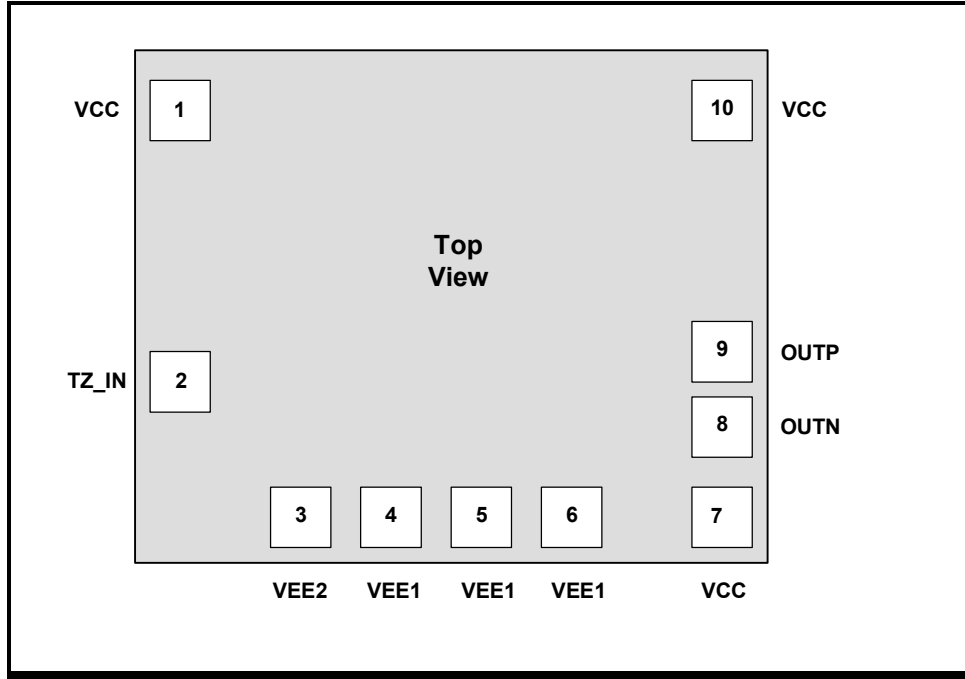

**Bondpad Description**

Pad No.	Name	Description
1	VCC	Positive supply (+3.3 V), pads 1, 7 & 10 are connected on chip. Only one pad needs to be bonded.
2	TZ_IN	Input pad (connect to photodetector anode).
3	VEE2	Negative supply (0V) – Note this is separate ground for the input stage, which is AC coupled on chip. There is no DC current through this pad.
4	VEE1	Negative supply (0V), pads 4, 5 & 6 are connected on chip. Only one pad needs to be bonded.
5	VEE1	Negative supply (0V), pads 4, 5 & 6 are connected on chip. Only one pad needs to be bonded.
6	VEE1	Negative supply (0V), pads 4, 5 & 6 are connected on chip. Only one pad needs to be bonded.
7	VCC	Positive supply (+3.3 V), pads 1, 7 & 10 are connected on chip. Only one pad needs to be bonded.
8	OUTN	Negative differential voltage output.
9	OUTP	Positive differential voltage output.
10	VCC	Positive supply (+3.3 V), pads 1, 7 & 10 are connected on chip. Only one pad needs to be bonded.

## Functional Description

### Amplifier front-end

The transimpedance front-end amplifies an input current from a photodetector, at pin TZ\_IN, to produce an output voltage with the feedback resistor  $R_f$  determining the level of amplification (see the functional block diagram on page 1). An automatic gain control loop varies this resistor, to ensure that the output from the front-end does not saturate the output driver stage that follows. This gain control allows input signals of up to 2.6 mA peak.

The input pin TZ\_IN is biased at 1.5 V below the supply voltage VCC, allowing a photodetector to have a constant reverse bias by connecting the cathode to 3.3 V. This enables full single rail operation.

The front-end stage has its own supply ground connection (VEE2) to achieve optimum noise performance and maintain integrity of the high-speed signal path. The front-end shares the VCC

(+3.3 V) connection with the remainder of the circuitry, which has a separate ground (VEE1).

### Output driver stage

The output driver acts as a buffer stage, capable of swinging up to 300 mVpk-pk differential into a 100  $\Omega$  load. The small output swings allow ease of use with low voltage post amplifiers (e.g. 3.3 V parts). Increasing optical input level gives a positive-going output signal on the OUTP pin.

### Automatic Gain Control (AGC)

The AGC circuit monitors the voltages from the output driver and compares them to an internal reference level produced via the on-chip bandgap reference circuit. When this level is exceeded, the gain of the front-end is reduced by controlling the feedback resistor  $R_f$ .

A long time-constant integrator is used within the control loop of the AGC with a typical low frequency cut-off of 10 kHz.

## System Block Diagram

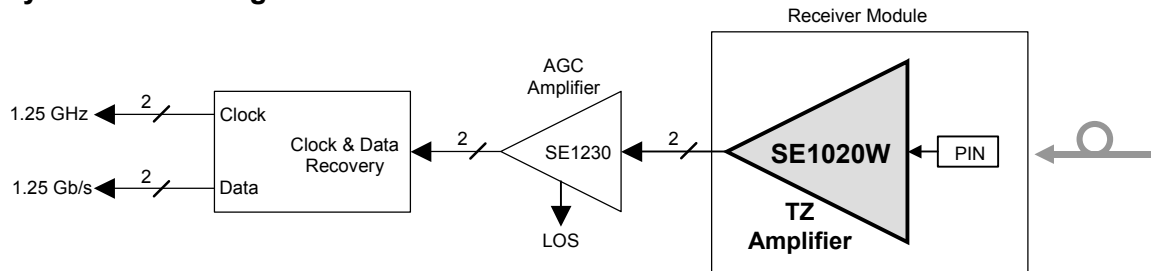

## Electrical Specifications

### Absolute Maximum Ratings

These are stress ratings only. Exposure to stresses beyond these maximum ratings may cause permanent damage to, or affect the reliability of the device. Avoid operating the device outside the recommended operating conditions defined below.

Symbol	Parameter	Min	Max	Unit
VCC	Supply Voltage	-0.7	6.0	V
V <sub>IO</sub>	Voltage at any input or output	-0.5	VCC+0.5	V
I <sub>IO</sub>	Current sourced into any input or output except TZ_IN	-20	+20	mA
I <sub>IO</sub>	Current sourced into pin TZ_IN	-5	+5	mA
V <sub>ESD</sub>	Electrostatic Discharge (100 pF, 1.5 kΩ) except TZ_IN	-2	2	kV
V <sub>ESD</sub>	Electrostatic Discharge (100 pF, 1.5 kΩ) pin TZ_IN	-0.25	0.25	kV
T <sub>stg</sub>	Storage Temperature	-65	150	°C

### Recommended Operating Conditions

Symbol	Parameter	Min	Typ	Max	Unit
VCC	Supply Voltage	3.1	3.3	3.5	V
T <sub>j</sub>	Operating Junction Temperature	-40		125	°C

### DC Electrical Characteristics

Symbol	Parameter	Min	Typ	Max	Unit
I <sub>CC max</sub>	Supply Current (max input current)		41	65	mA
I <sub>CC zero</sub>	Supply Current (zero input current)		33	52	mA
I <sub>agc</sub>	AGC Threshold	24			μA pk-pk
V <sub>in</sub>	Input Bias Voltage	VCC-1.57	VCC-1.52	VCC-1.47	V
V <sub>out</sub>	Output Bias Voltage		VCC-0.15		V
R <sub>out</sub>	Output Resistance	35	50	65	Ω

**AC Electrical Characteristics**

Symbol	Parameter	Min	Typ	Max	Unit
BW (3dB)	Small Signal Bandwidth at -3dB point	0.95	1.2		GHz
Tz	Differential Transimpedance (50 Ω on each output, f = 100 MHz)	2.9	4.0	5.4	kΩ
Dri	Input Data Rate	50		1250	Mb/s
Voutmax	Maximum Differential Output Voltage			300	mV pk-pk
Fif	Low Frequency Cut-off		10	20	kHz
I <sub>OL</sub>	Input Current before overload (1.25 Gb/s NRZ data)	2600			μA pk-pk
Pol	Optical Overload	+3.3			dBm
Nrms	Input Noise Current (in 1 GHz)		180	255	nA rms

DC and AC electrical characteristics are specified under the following conditions:

Supply Voltage (VCC) ..... 3.1 V to 3.5 V  
 Junction Temperature (Tj) ..... -40°C to 125°C  
 Load Resistor (R<sub>L</sub>) ..... 50 Ω AC coupled via 220 nF, for each output  
 Photodetector Capacitance (Cd) ..... 0.7 pF  
 Input bond wire inductance ..... 1 nH  
 Photodetector responsivity ..... 0.6 A/W  
 Transimpedance (Tz) measured with 4 μA mean photocurrent

### Bondpad Configuration

The diagram below shows the bondpad configuration of the SE1020W Transimpedance Amplifier: Note that the diagram is not to scale. Bondpad openings are 82  $\mu\text{m}$  x 82  $\mu\text{m}$ . There are three VCC and three VEE1 pads respectively are connected on-chip and only one pad of each type is required to be bonded out.

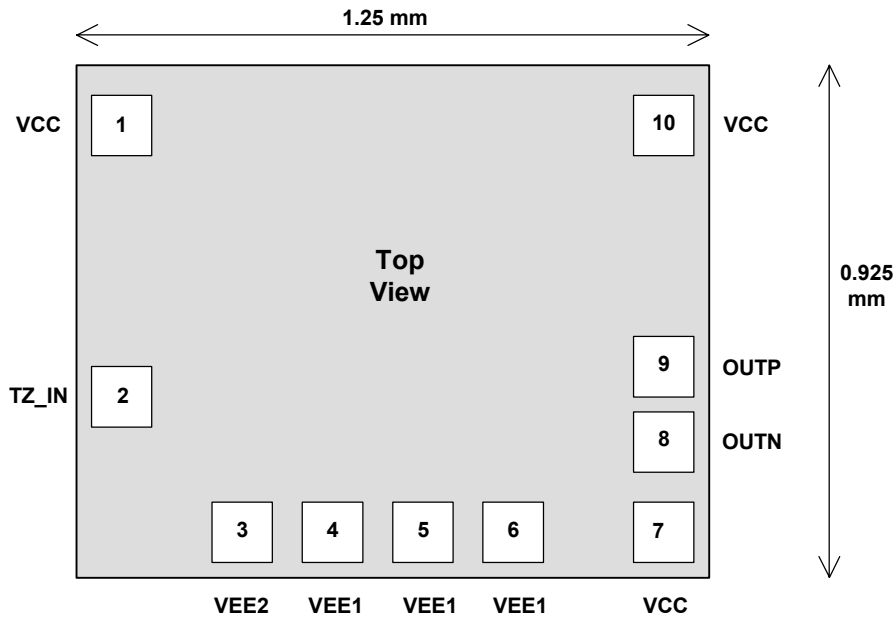

### Applications Information

For optimum performance it is recommended that the device be configured as in the circuit shown in the diagram below.

Note that all VCC pads (1, 7, 10) are connected on-chip, as are the VEE1 pads (4, 5, 6), and only one pad of each type is required to be bonded out. However, in order to minimize inductance for optimum high speed performance, it is recommended that all power pads are wire bonded. The VEE2 pad is not connected on chip to VEE1 and must be bonded out separately.

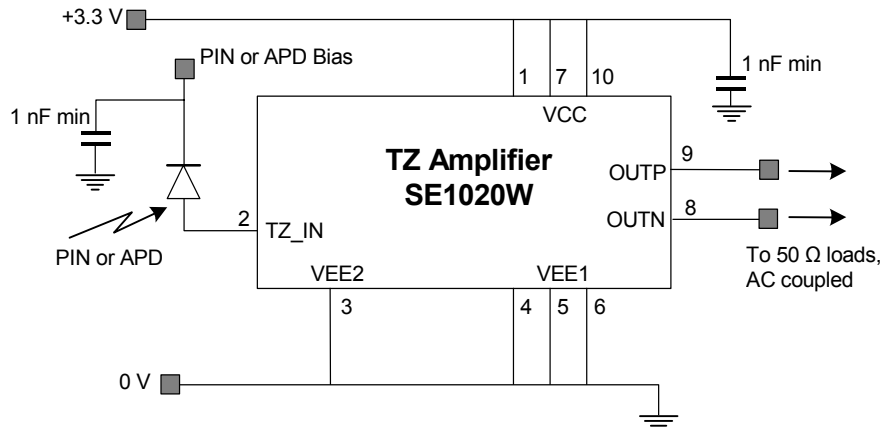

<http://www.sige.com>

**Headquarters: Canada**

Phone: +1 613 820 9244

Fax: +1 613 820 4933

2680 Queensview Drive

Ottawa ON K2B 8J9 Canada

[sales@sige.com](mailto:sales@sige.com)

**U.S.A.**

1150 North First Street  
San Jose, CA  
USA 95112

Phone: +1 408 998 5060

Fax: +1 408 998 5062

**United Kingdom**

1010 Cambourne Business Park  
Cambourne  
Cambridge CB3 6DP

Phone: +44 1223 598 444

Fax: +44 1223 598 035

Product Preview

The datasheet contains information from the product concept specification. SiGe Semiconductor reserves the right to change information at any time without notification.

Preliminary

The datasheet contains information from the design target specification. SiGe Semiconductor reserves the right to change information at any time without notification.

Final

The datasheet contains information from the final product specification. SiGe Semiconductor reserves the right to change information at any time without notification. Production testing may not include testing of all parameters.

Information furnished is believed to be accurate and reliable and is provided on an "as is" basis. SiGe Semiconductor Inc. assumes no responsibility or liability for the direct or indirect consequences of use of such information nor for any infringement of patents or other rights of third parties, which may result from its use. No license or indemnity is granted by implication or otherwise under any patent or other intellectual property rights of SiGe Semiconductor Inc. or third parties. Specifications mentioned in this publication are subject to change without notice. This publication supersedes and replaces all information previously supplied. SiGe Semiconductor Inc. products are NOT authorized for use in implantation or life support applications or systems without express written approval from SiGe Semiconductor Inc.

Copyright 2002 SiGe Semiconductor  
All Rights Reserved