

**DESCRIPTION**

The SD1144 is a 12.5 V Class C epitaxial silicon NPN planar transistor designed primarily for UHF communications. This device utilizes improved metallization to achieve infinite VSWR at rated operating conditions.

**IMPORTANT:** For the most current data, consult MICROSEMI's website: <http://www.microsemi.com>

**KEY FEATURES**

- 470 MHz
- 12.5 Volts
- Common Emitter
- Collector Efficiency 60%
- $P_{OUT} = 2.0$  W Min.
- $G_p = 9$  dB Gain

**APPLICATIONS/BENEFITS**

- UHF Mobile Applications

**ABSOLUTE MAXIMUM RATINGS (T<sub>CASE</sub> = 25°C)**

Symbol	Parameter	Value	Unit
$V_{CBO}$	Collector-Base Voltage	36	V
$V_{CEO}$	Collector-Emitter Voltage	16	V
$V_{CES}$	Collector-Emitter Voltage	36	V
$V_{EBO}$	Emitter-Base Voltage	4.0	V
$I_C$	Device Current	0.4	A
$P_{DISS}$	Power Dissipation	5.0	W
$T_J$	Junction Temperature	+200	°C
$T_{STG}$	Storage Temperature	-65 to +150	°C

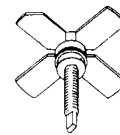

.280 4L STUD (M122)  
epoxy sealed

**THERMAL DATA**

$R_{TH(j-c)}$	Junction-Case Thermal Resistance	35	°C/W
---------------	----------------------------------	----	------

**PIN CONNECTION**

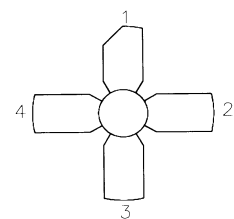

1. Collector      3. Base  
2. Emitter        4. Emitter

**STATIC ELECTRICAL SPECIFICATIONS (T<sub>CASE</sub> = 25°C)**

Symbol	Test Conditions	SD1144			Units
		Min.	Typ.	Max.	
<b>BV<sub>CES</sub></b>	<b>I<sub>C</sub> = 50 mA</b> <b>V<sub>BE</sub> = 0 V</b>	36	—	—	V
<b>BV<sub>CEO</sub></b>	<b>I<sub>C</sub> = 50 mA</b> <b>I<sub>B</sub> = 0 mA</b>	16	—	—	V
<b>BV<sub>EBO</sub></b>	<b>I<sub>E</sub> = 1 mA</b> <b>I<sub>C</sub> = 0 mA</b>	4.0	—	—	V
<b>I<sub>CBO</sub></b>	<b>V<sub>CB</sub> = 15 V</b> <b>I<sub>E</sub> = 0 mA</b>	—	—	1.0	mA
<b>h<sub>FE</sub></b>	<b>V<sub>CE</sub> = 5 V</b> <b>I<sub>C</sub> = 100 mA</b>	20	—	200	—

**DYNAMIC ELECTRICAL SPECIFICATIONS (T<sub>CASE</sub> = 25°C)**

Symbol	Test Conditions	SD1144			Units
		Min.	Typ.	Max.	
<b>P<sub>OUT</sub></b>	<b>f = 470 MHz</b> <b>P<sub>IN</sub> = 0.25 W</b> <b>V<sub>CE</sub> = 12.5 V</b>	2.0	—	—	W
<b>G<sub>P</sub></b>	<b>f = 470 MHz</b> <b>P<sub>IN</sub> = 0.25 W</b> <b>V<sub>CE</sub> = 12.5 V</b>	9.0	—	—	dB
<b>η<sub>C</sub></b>	<b>f = 175 MHz</b> <b>P<sub>IN</sub> = 0.25 W</b> <b>V<sub>CE</sub> = 12.5 V</b>	60	—	—	%
<b>C<sub>OB</sub></b>	<b>f = 1 MHz</b> <b>V<sub>CB</sub> = 12.5 V</b>	—	—	15	pF

**IMPEDANCE DATA**

Freq.	Z <sub>IN</sub> (Ω)	Z <sub>CL</sub> (Ω)
470 MHz	2.24 + j 6.5	13.0 - j 8.65

PACKAGE STYLE M122

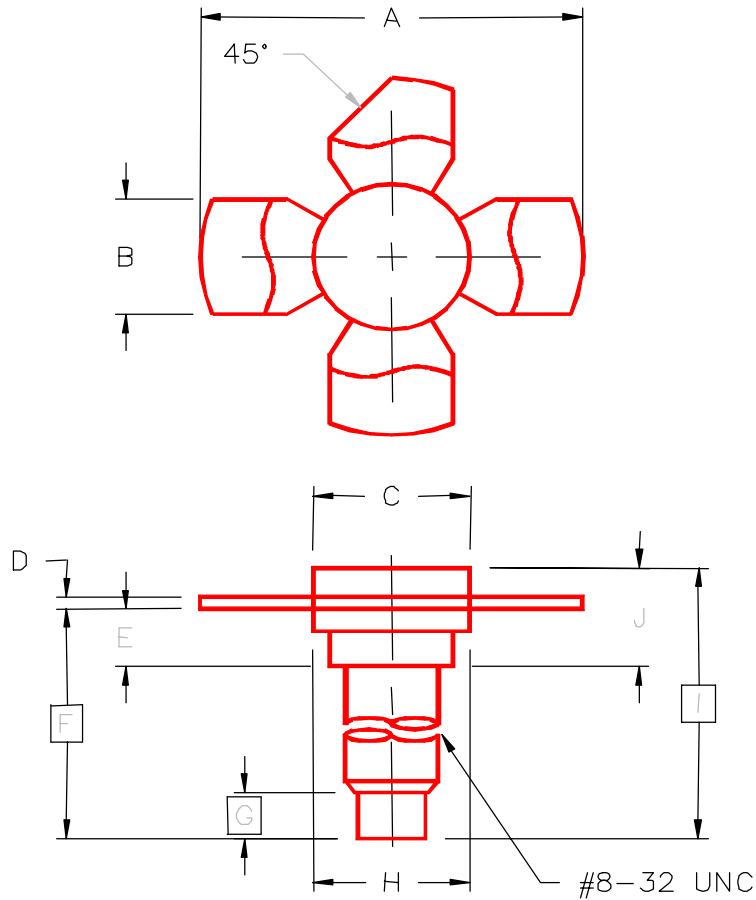

	MINIMUM INCHES/MM	MAXIMUM INCHES/MM		MINIMUM INCHES/MM	MAXIMUM INCHES/MM
A	1.010/25,65	1.055/26,80	I	.640/16,26	
B	.220/5,59	.230/5,84	J	.175/4,45	.217/5,51
C	.270/6,86	.285/7,24			
D	.003/0,08	.007/0,18			
E	.117/2,97	.137/3,48			
F	.572/14,53				
G	.130/3,30				
H	.275/6,99	.285/7,24			



SD1144

**RF & MICROWAVE TRANSISTORS**

**PRODUCT PREVIEW**

www.Microsemi.com

NOTES