

SBR735 THRU SBR760

CURRENT 7.5Amperes
VOLTAGE 35 to 60 Volts

Features

- Plastic Package has Underwriters Laboratory Flammability Classification 94V-0
- Metal silicon junction, majority carrier conduction
- Guard ring for overvoltage protection
- Low power loss, high efficiency
- High current capability, Low forward voltage drop
- Single rectifier construction
- High surge capability
- For use in low voltage, high frequency inverters, free wheeling, and polarity protection applications
- High temperature soldering guaranteed : 250 °C /10 seconds, 0.25"(6.35mm) from case

TO-220A

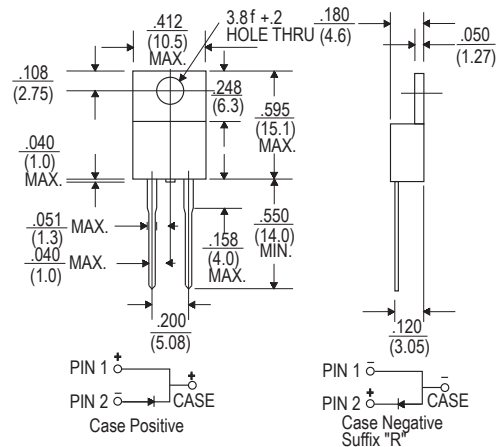

Dimensions in inches and (millimeters)

Mechanical Data

- Case : JEDEC TO-220A molded plastic body
- Terminals : Lead solderable per MIL-STD -750, Method 2026
- Polarity : As marked
- Mounting Position : Any
- Weight : 0.08 ounce, 2.24 gram

Maximum Ratings and Electrical Characteristics

(Ratings at 25 °C ambient temperature unless otherwise specified, single phase, half wave, resistive or inductive load. For capacitive load, derate by 20%)

	Symbols	SBR735	SBR745	SBR750	SBR760	Units
Maximum repetitive peak reverse voltage	V _{RRM}	35	45	50	60	Volts
Maximum RMS voltage	V _{RMS}	25	32	35	42	Volts
Maximum DC blocking voltage	V _{DC}	35	45	50	60	Volts
Maximum average forward rectified current (see Fig. 1)	I _(AV)	7.5				Amps
Repetitive peak forward current(square wavr, 20KHZ) at T _C =105 °C	I _{FRM}	15.0				Amps
Peak forward surge current 8.3ms single half sine-wave superimposed on rated load (JEDEC method)	I _{FSM}	150.0				Amps
Maximum instantaneous forward voltage at 7.5A (Note 1)	V _F	0.65		0.75		Volts
Maximum instantaneous reverse current at rated DC blocking voltage (Note1)	T _A =25 °C	1.0				mA
	T _A =125 °C	15		50		
Typical thermal resistance (Note 2)	R _{θJC}	2.5				°C /W
Operating junction temperature range	T _J	-65 to +125				°C
Storage temperature range	T _{STG}	-65 to +150				°C

Notes:

- (1) Pulse test: 300µS pulse width, 1% duty cycle
- (2) Thermal resistance from junction to case



RATINGS AND CHARACTERISTIC CURVES SBR735 THRU SBR760

FIG.1-FORWARD CURRENT DERATING CURVE

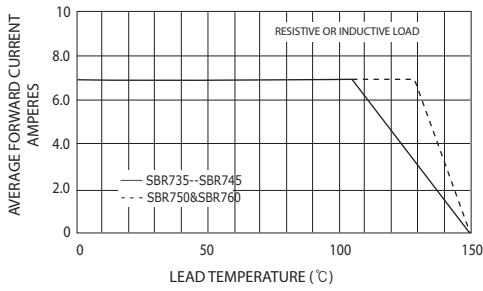

FIG.2-MAXIMUM NON-REPETITIVE PEAK FORWARD SURGE CURRENT

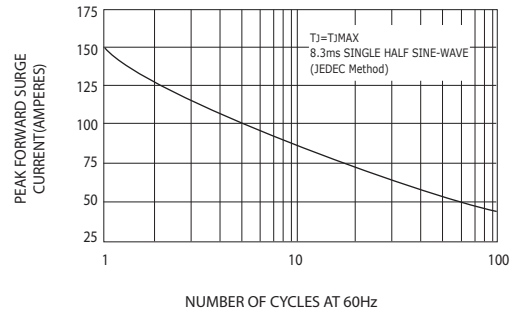

FIG.3-TYPICAL INSTANTANEOUS FORWARD CHARACTERISTICS

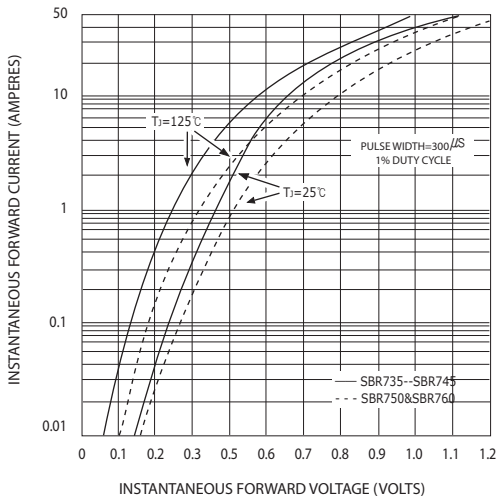

FIG.4-TYPICAL REVERSE CHARACTERISTICS

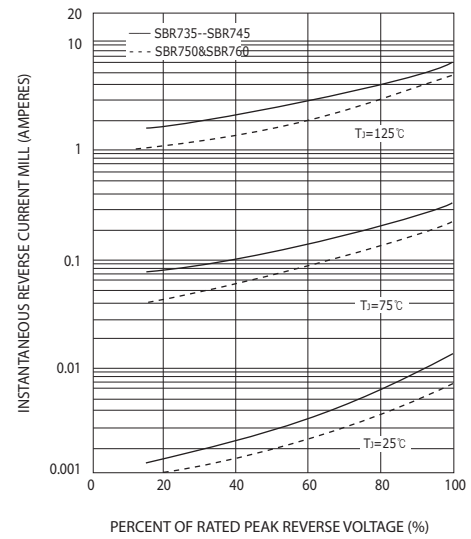

FIG.5-TYPICAL JUNCTION CAPACITANCE

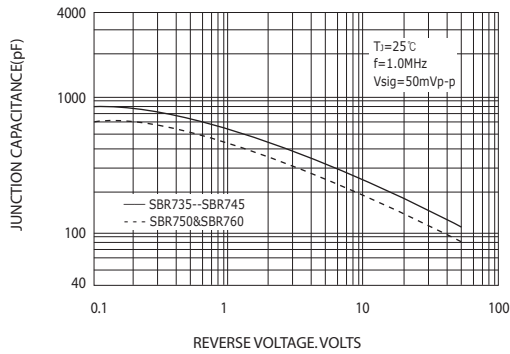

FIG.6-TYPICAL TRANSIENT THERMAL IMPEDANCE

