

**Features**

- Blue colored transparency lens type
- $\phi 3\text{mm}$ (T-1) all plastic mold type

**Outline Dimensions**

unit : mm

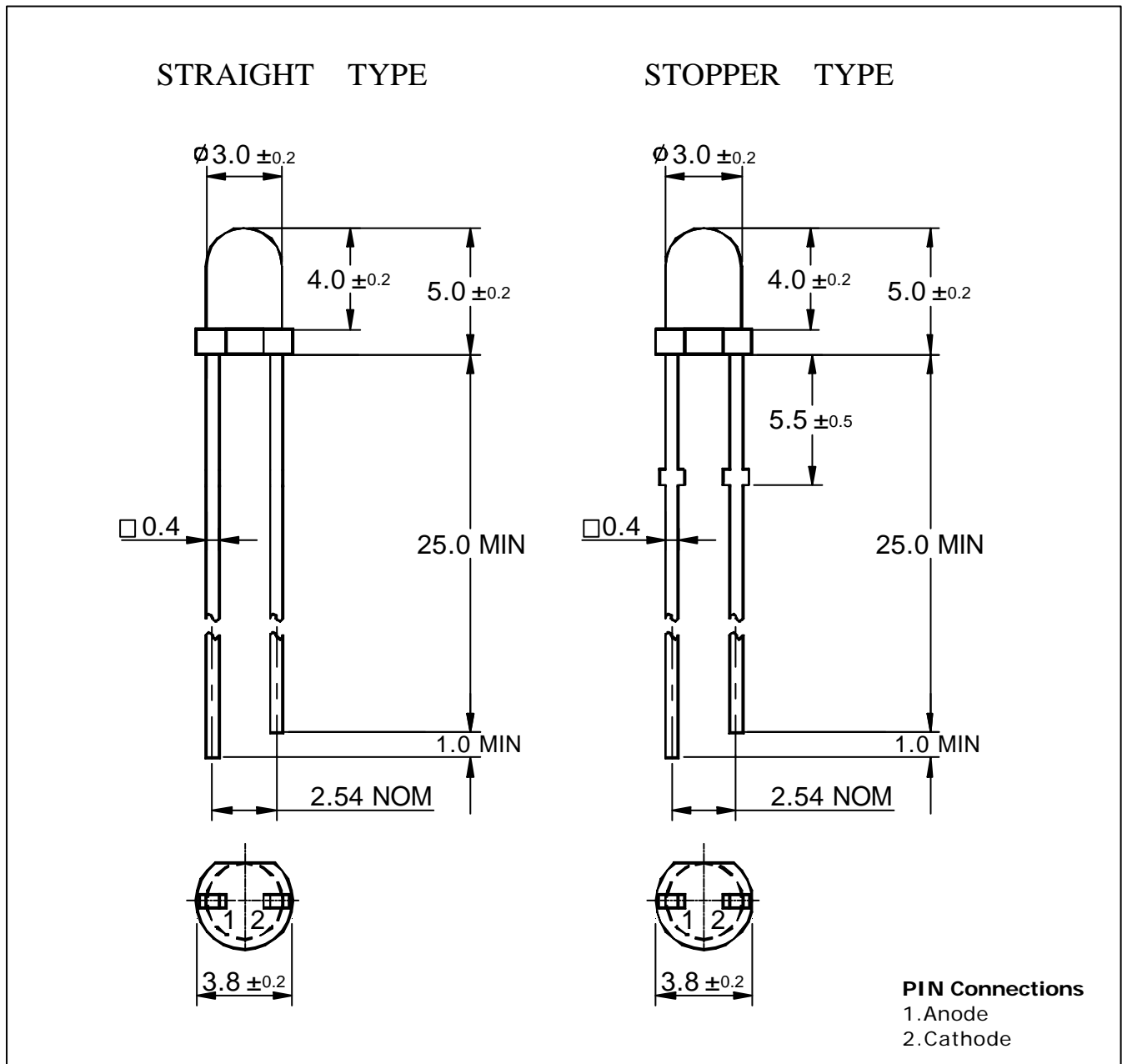

**Absolute maximum ratings**

Characteristic	Symbol	Ratings	Unit
Power Dissipation	$P_D$	85	mW
Forward Current	$I_F$	20	mA
* <sup>1</sup> Peak Forward Current	$I_{FP}$	50	mA
Reverse Voltage	$V_R$	4	V
Operating Temperature	$T_{opr}$	-25 85	
Storage Temperature	$T_{stg}$	-30 100	
* <sup>2</sup> Soldering Temperature	$T_{sol}$	260 for 5 seconds	

\*1. Duty ratio = 1/16, Pulse width = 0.1ms

\*2. Keep the distance more than 2.0mm from PCB to the bottom of LED package

**Electrical Characteristics**

Characteristic	Symbol	Test Condition	Min.	Typ.	Max.	Unit
Forward Voltage	$V_F$	$I_F = 10\text{mA}$	-	3.7	4.2	V
Luminous Intensity	$I_V$	$I_F = 10\text{mA}$	10	30	-	mcd
Peak Wavelength	$\lambda_p$	$I_F = 10\text{mA}$	-	435	-	nm
Spectrum Bandwidth		$I_F = 10\text{mA}$	-	60	-	nm
Reverse Current	$I_R$	$V_R = 4\text{V}$	-	-	10	$\mu\text{A}$
* <sup>3</sup> Half angle	$\theta_{1/2}$	$I_F = 10\text{mA}$	-	$\pm 17$	-	deg

\*3.  $\theta_{1/2}$  is the off-axis angle where the luminous intensity is 1/2 the peak intensity

Characteristic Diagrams

Fig. 1  $I_F - V_F$

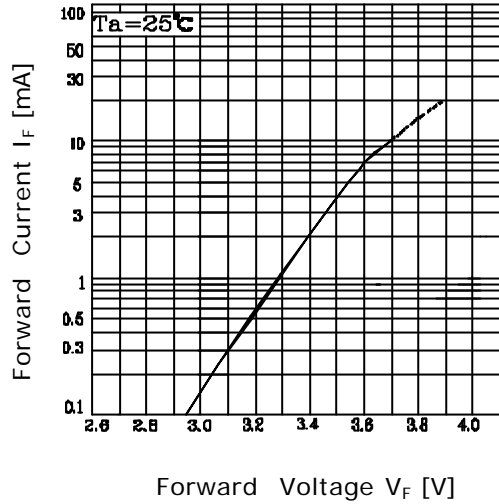

Fig. 2  $I_V - I_F$

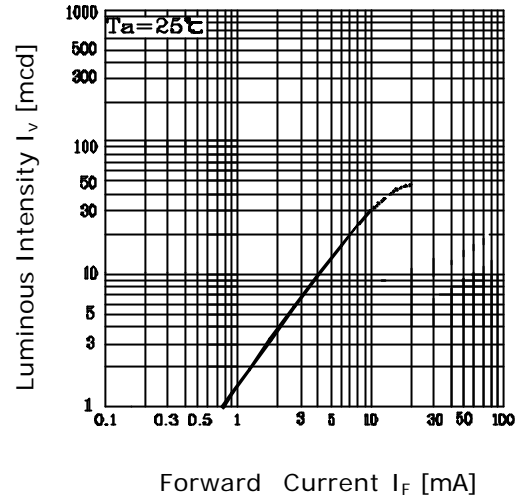

Fig. 3  $I_F - T_a$

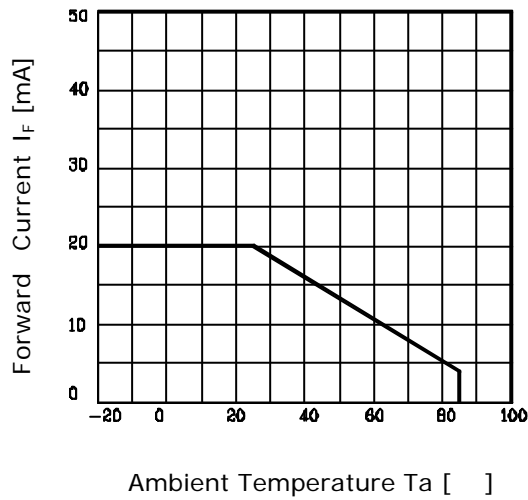

Fig.4 Spectrum Distribution

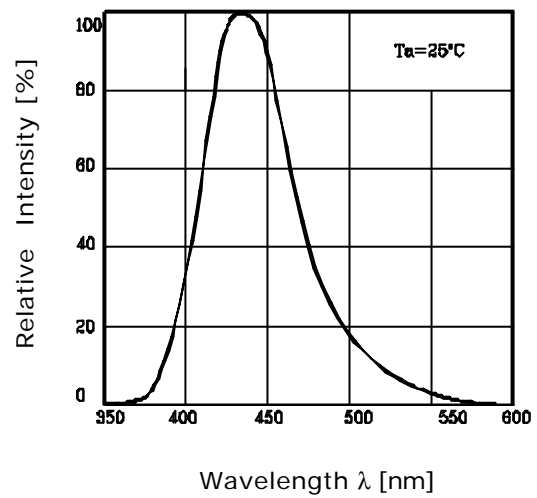

Fig. 5 Radiation Diagram

