

Switching Power Supply

S82D

Powerful Yet Compact 300 W or 600 W Power Supplies

- 5 V, 12 V, or 24 V output voltages available.
- 85 to 132 VAC or 170 to 264 VAC switchable input voltage for international use.
- Equipped with overvoltage and overload protection and remote sensing and control functions.
- Fan alarm signal warns of impending fan malfunction.
- Parallel connection of two power supplies possible for loads drawing high current.
- Two pairs of output terminals simplify wiring of two loads (300 W).
- Optional multiple output terminal available (600 W).

RC

Ordering Information

Rated input voltage	Power ratings	Output		Model
		Voltage	Current	
100/200VAC	300 W	5 VDC	60 A	S82D-3005
		12 VDC	27 A	S82D-3012
		24 VDC	14 A	S82D-3024
	600 W	5 VDC	120 A	S82D-6005
		12 VDC	53 A	S82D-6012
		24 VDC	27 A	S82D-6024

Model Number Legend:

S82D - -

1 2

1. Power Ratings
 30: 300 W
 60: 600 W

2. Output Voltage
 05: 5 V
 12: 12 V
 24: 24 V

■ Accessories (Order Separately)

Mounting Brackets

Item	Bottom-mounting		Side-mounting	
Model	S82Y-D30B (300 W)	S82Y-D60B (600 W)	S82Y-D30S (300 W)	S82Y-D60S (600 W)
Applicable Power Supply Unit	S82D-30□□	S82D-60□□	S82D-30□□	S82D-60□□

Terminal Expansion Bracket

Model	S82Y-D60T
Applicable Power Supply Unit	S82D-60□□

Connection Kit

Model	S82Y-D30A	S82Y-D60A
Applicable Power Supply Unit	S82D-30□□	S82D-60□□

Specifications

■ Ratings/Characteristics

Item		300 W	600 W	
Efficiency (typical)		74% to 84% (depending on types)		
Life expectancy		10 yrs. min. (Used at 40°C at the rated input with a 50% load. The life expectancy of the fan is lower.)		
Input	Voltage (AC only)	Switchable between 100 V (85 to 132 V) and 200 V (170 to 264 V)		
	Frequency	47 to 450 Hz		
	Current (with rated I/O)	100 V input	8 A max.	14 A max.
		200 V input	4 A max.	7 A max.
	Leakage current (with rated I/O)	100 V input	0.5 mA max.	
		200 V input	1 mA max.	
	Inrush current (with rated I/O)	100 V input	25 A max.	30 A max.
		200 V input	50 A max.	60 A max.
Noise filter	Yes			
Output	Voltage fluctuation	3% max. (combined input, load, and temperature variations)		
	Voltage adjustment range	±10% (adjustable with variable resistor (V.ADJ))		
	Ripple	2% (p-p) max.		
	Input variation influence	0.4% max. (85 to 132 VAC/170 to 264 VAC input, 100% load)		
	Load variation influence	0.8% max. (rated input, 0% to 100% load)		
	Temperature variation influence	0.04%/°C max. (0° to 50°C, with rated input and output)		
	Rise time	300 ms max. (output voltage rise to 90%, with rated input and output)		
	Hold time	20 ms min.		
Additional functions	Overload protection	105% min. of rated load current, inverted L drop, automatic reset (output shut off after 5 s, reset by input reset)		
	Overvoltage protection	120% of rated output voltage (typical), shut-off type, reset by input reset		
	Fan alarm	Relay output, connector SPST, 250 VAC, 1 A load resistance, but switching capacity is 125 VA		
	Remote sensing	Yes		
	Remote control	Yes		
Parallel connection	Yes			
Other	Ambient temperature	Operating: See the derating curve in the "Engineering Data" section Storage: -25° to 85°C		
	Ambient humidity	Operating: 25% to 85% Storage: 20% to 95%		
	Dielectric strength	2000 VAC, 50/60Hz for 1 min (between all inputs and outputs/housing) 500 VDC for 1 min (between all inputs and outputs and the housing)		
	Insulation resistance	100 MΩ min. at 500 VDC (between all inputs and outputs/housing)		
	Vibration resistance	Malfunction: 10 to 55 Hz, 0.75-mm double amplitude (approx. 4.5G) each in X, Y, and Z directions for 2 hours.		
	Shock resistance	Malfunction: 294 m/s ² (30G), 3 times each in ±X, ±Y, and ±Z directions		
	Output indicator	Yes (red)		
	Electromagnetic interference	Meets FCC class A standards		
	Approved standards	UL 1012, CSA E.B. 1402C		
	Weight	2.5 kg max.	4 kg max.	

Note: Be sure to remove short bar attached between FC and ACG terminals before performing dielectric strength test or insulation resistance test for surge absorber is connected across input lines.

Engineering Data

■ Derating Curve

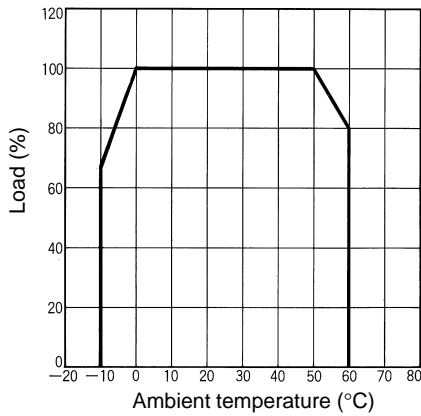

Note: The derating curve differs depending on the mounting direction of the Power Supply. The curve above was obtained with the Power Supply mounted in the standard position.

■ Overload Protection

The protective function prevents damage to the load as well as the Power Supply itself due to overload. If the load current rises above the overload set value (105% of the rated load current), the protective function will engage and the voltage will be reduced. Reset is automatic, so the Power Supply will return to normal operation when the overload condition is corrected.

If an overload condition continues for more than 5 s, the output will be shut off. In this situation, reset is not automatic. The input power must be turned off for at least 30 s, and then turned on again to reset the Power Supply.

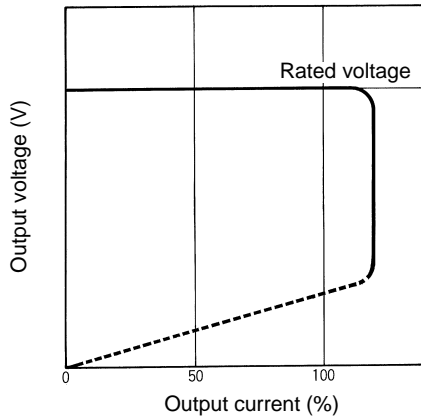

Output shut off after 5 s

■ Overvoltage Protection

The protective function prevents damage to the load as well as the Power Supply itself due to overvoltage. The output is shut off if the output voltage rises above about 120% of the rated voltage. The input power must be turned off for at least 30 s, and then turned on again to reset the Power Supply.

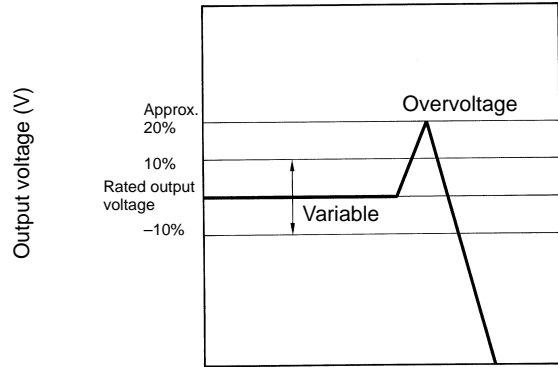

■ Inrush Current, Rise Time, Hold Time

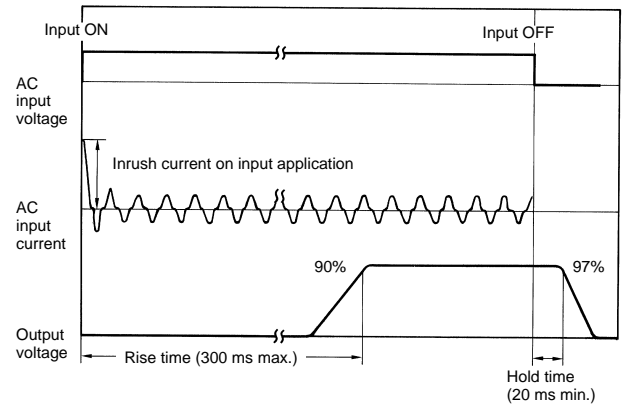

Operation

Remote Sensing Function

This function corrects a voltage drop in the load wiring. When using the remote sensing function, remove the short bars from the remote sensing terminals as shown in the following diagram.

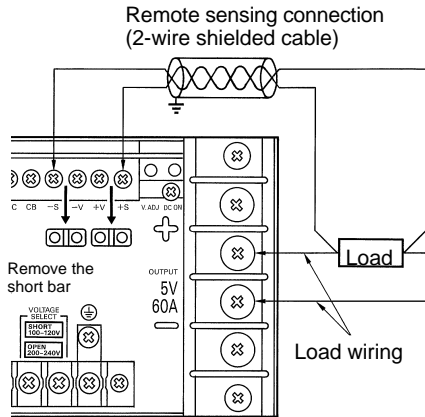

- Note:**
1. When the voltage drop in the load wiring is large, the overvoltage protection function might engage just from the increase in voltage to correct the voltage drop, so be sure to use high capacity wiring.
 2. If the +S and +V terminals are left unconnected, the high voltage protection function will engage and the output voltage will be cut off. If the -S and -V terminals are left unconnected, the output voltage will increase about 5%.

Remote Control Function

This function allows the output voltage to be turned on and off with an external signal (as long as the input voltage is being applied). When using the remote control function, remove the short bar (attached at ex-factory condition) from the remote control terminals and connect a switch or transistor as shown in the diagram below.

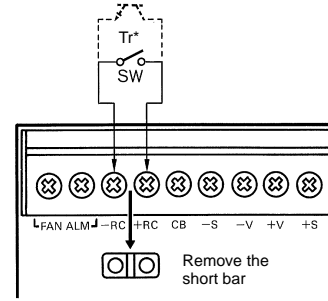

Level	Output voltage
L (0.8 V max.)	ON
H (2 V min.)	OFF

Note: The remote control circuit is insulated from input, output, and GR.

Fan Alarm

When the speed of the internal fan drops, the fan alarm output (SPST-NO) will turn ON (shorted).

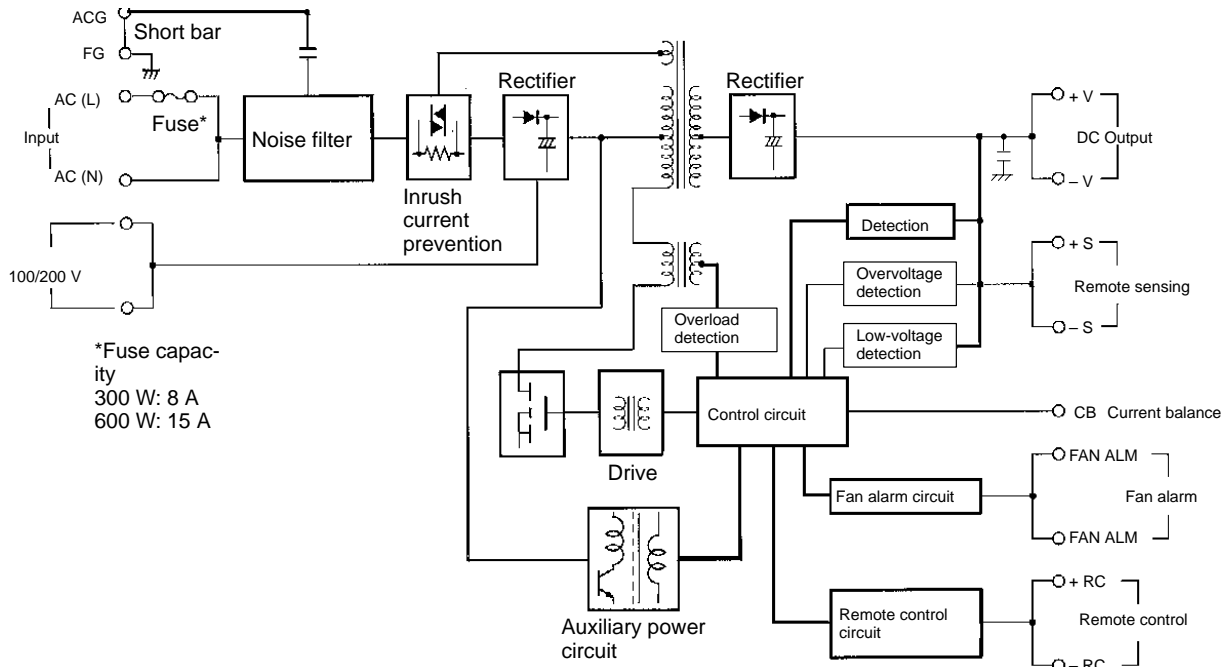
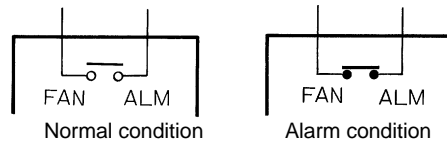

Dimensions

Note: All units are in millimeters unless otherwise indicated.

S82D-30□□ (300 W)

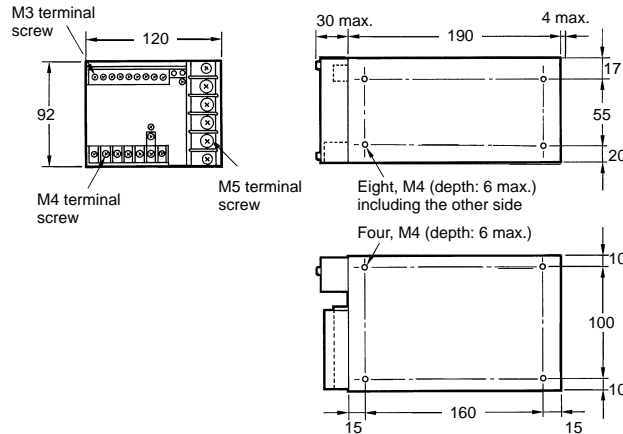
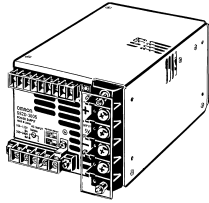

Mounting Holes Side View

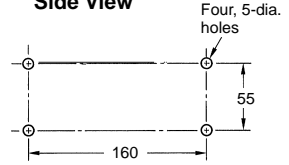

Bottom View

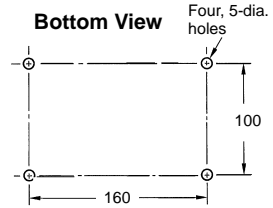

S82D-60□□ (600 W)

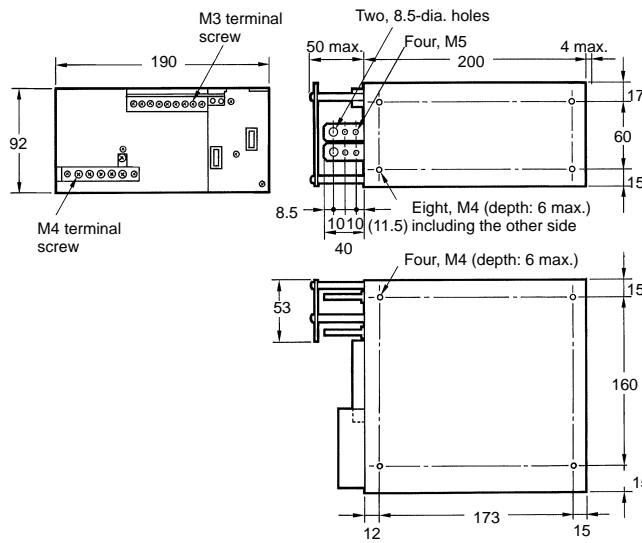
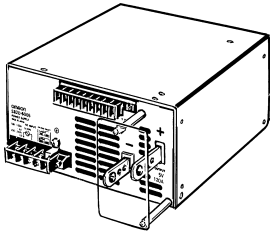

Mounting Holes Side View

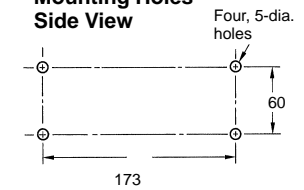

Bottom View

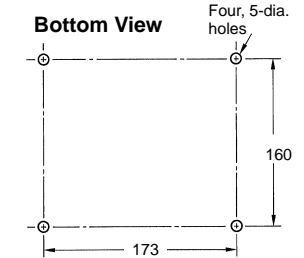

Mounting Bracket S82Y-D30B (300 W)

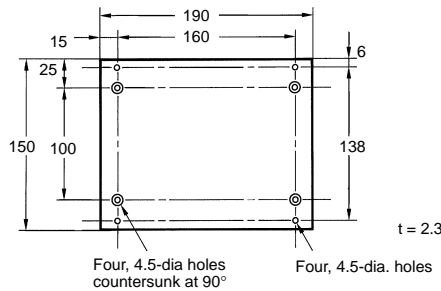
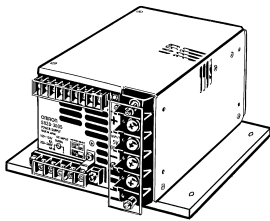

Mounting Holes

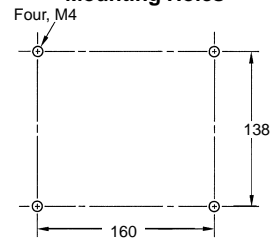

S82Y-D60B (600 W)

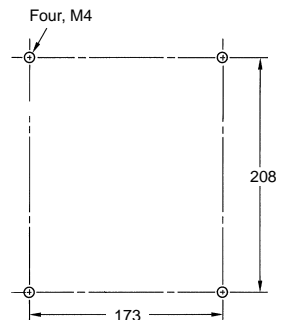
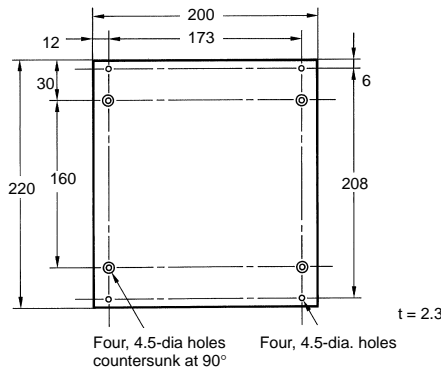
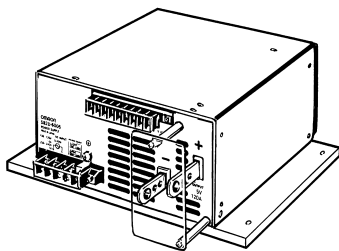

**Mounting Bracket
S82Y-D30S (300 W)**

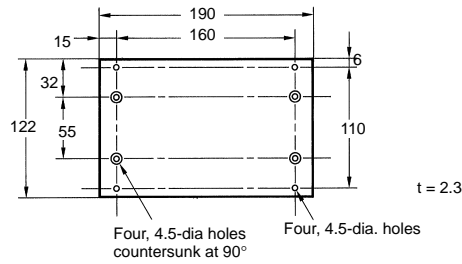
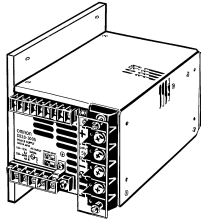

Mounting Holes

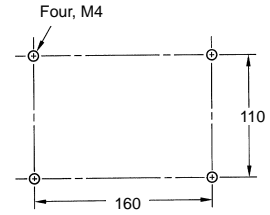

S82Y-D60S (600 W)

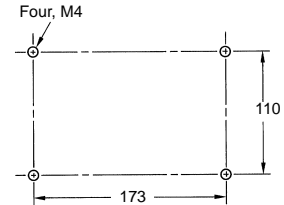
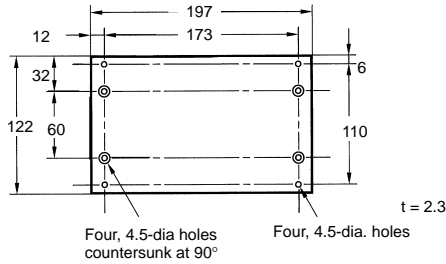
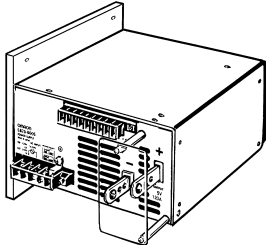

Installation

■ **Terminal Arrangement**

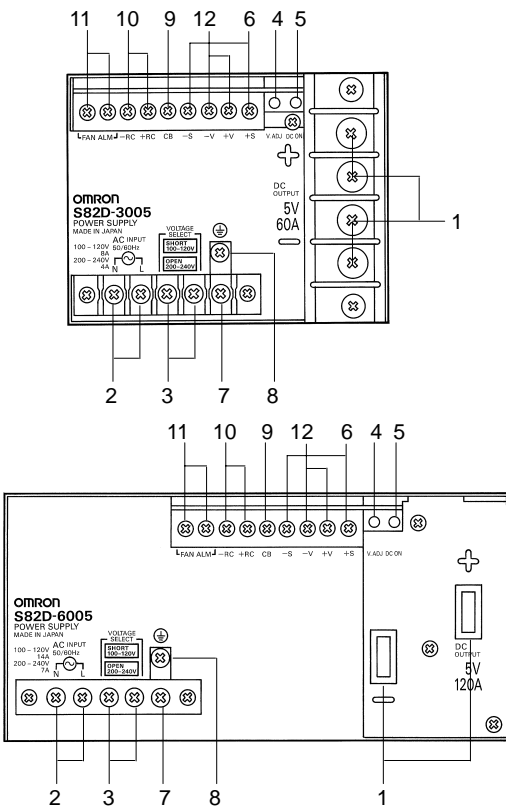

1. **DC Output Terminals:** Connect load wiring.
2. **Input Terminals:** Connect input wiring.
3. **Voltage Select Terminals:** Switch the input voltage by connecting or removing the short bar.
(short circuited: 100 to 120 V; open: 200 to 240 V)
4. **V. ADJ Adjustor:** Use to adjust the output voltage.
5. **Output LED Indicator:** Lights when DC current is being output.
6. **Remote Sensing Terminals:** Corrects the voltage drop in the load lines.
7. **ACG Terminal:** The intermediate point of the input filter. Shorted to FG terminal for normal operation.
8. **FG Terminal:** Shorted to the housing, and connected to a ground line.
9. **Current Balance Terminal:** Connected to the CB terminal of another Power Supply wired in parallel.
10. **Remote Control Terminals:** Connected to an external device to enable remote control of the output while the input voltage is being applied.
11. **Fan Alarm Output:** Turns ON (shorted) when the speed of the internal fan drops.
12. **Output Voltage Monitoring Terminals:** Take-off from the DC output terminals. Connected to the remote sensing terminals (+S and -S) when the remote sensing function is not used.

Precautions

Mounting

Providing adequate cooling when installing the Power Supply will extend its long-term reliability.

When installing two or more Power Supplies side-by-side, allow at least 10 mm spacing between them, as shown in the diagram below.

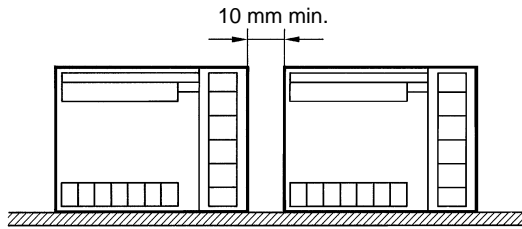

The Power Supply is cooled by air forced through it by the internal fan. Don't obstruct the ventilation holes in the front and back surfaces of the unit.

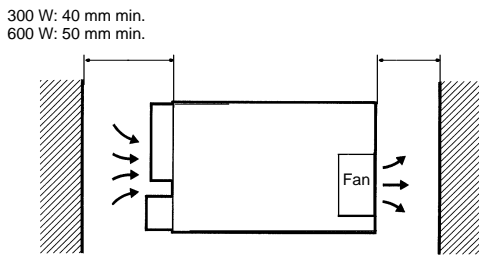

Take care to minimize dirt, dust, and other air-borne debris which could interfere with the passage of cooling air.

Switching the Input Voltage between 100 to 120 and 200 to 240 V

Select 100 to 120 or 200 to 240 V input voltage by shorting or opening the input voltage switching terminals, as shown in the diagram below. (Factory set to 200 to 240 V operation.)

100 to 120 V Input

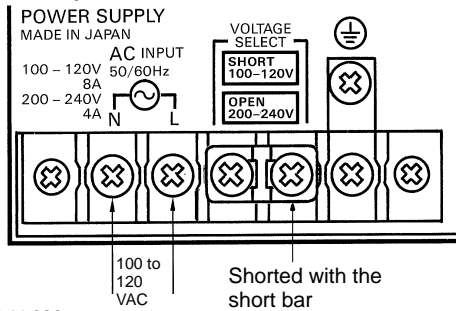

200 to 240 V Input

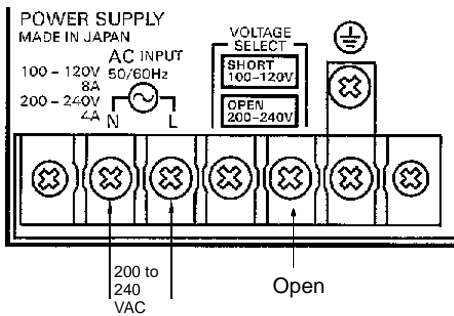

Terminal Expansion Bracket

A terminal expansion bracket is available for use with the 600 W Power Supply when several loads need to be connected.

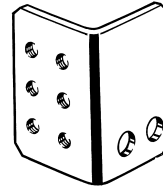

S82Y-D60T

- Brackets: 2
- M4 x 8 terminal screws: 12
- M5 x 12 terminal screws: 4

Replacing the Fan

It is necessary to replace the internal fan when the fan alarm output goes ON. Replacement fans can be ordered through your dealer. To replace the fan, remove the back cover as shown in the diagram below.

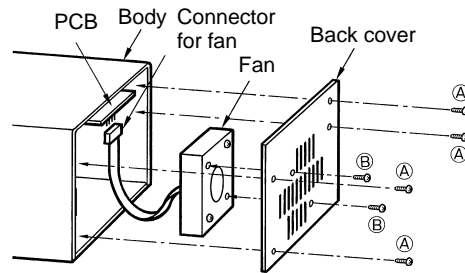

Generating Output Voltages (±)

S82D Power Supplies may be connected to provide floating output voltages (±) as shown below.

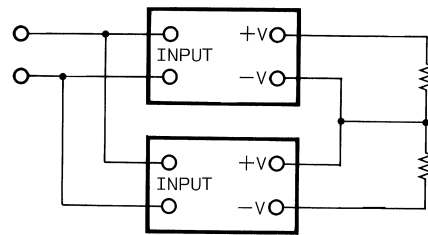

Series Connection

The output of two Power Supplies can be combined in series to double the output voltage as shown below.

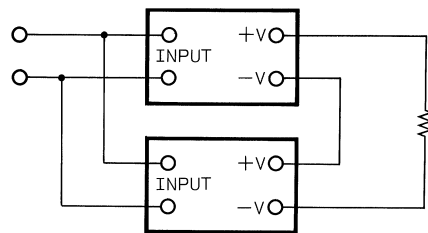

Parallel Connection (Master/Slave Operation)

The model S82D Power Supply has a built-in current balance function, allowing two units to be connected in parallel (master/slave operation) increasing the output current.

Master/Slave Operation

When connecting two Power Supplies for master/slave operation, use shielded wire to connect the current balance (CB) and -S terminals as shown below.

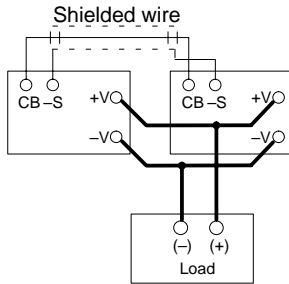

In master/slave operation, the Power Supply with the lower voltage adjustment set value (controlled by V. ADJ) is the master unit, and the Power Supply with the higher voltage adjustment set value is the slave unit.

NOTICE

A maximum of two units can be connected in parallel.

Block Diagram

To ensure that the voltage drop is the same between each Power Supply and load, the length and cross sectional area of the wires used should be uniform, and the system should be wired as in figure below.

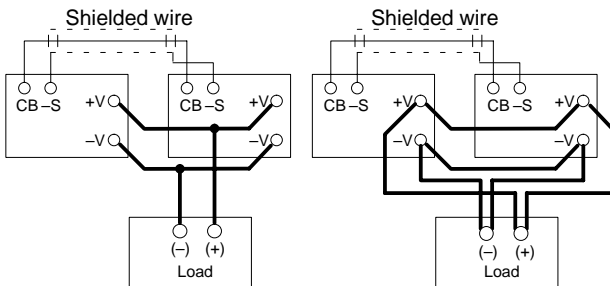

Do not wire the Power Supplies as shown below. It will cause output voltage imbalance, so that one of the units will supply exceeding current, causing the overload protection to engage, resulting in an unstable current and reducing product life expectancy.

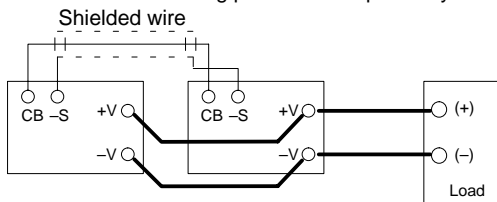

ALL DIMENSIONS SHOWN ARE IN MILLIMETERS.

To convert millimeters into inches, multiply by 0.03937. To convert grams into ounces, multiply by 0.03527.

Wiring

Use high capacity wiring between the Power Supplies and the load in order to minimize voltage drops due to wire resistance. A parallel connection kit (sold separately) is available. The kit includes a bar to connect the outputs, and shielded wire to connect the current balance and -S terminals.

Power Supply	Connection kit
S82D-300 W	S82Y-D30A
S82D-600 W	S82Y-D60A

When using lead wires, the wires should meet the specifications in the following table.

Model	Cross sectional area	Length
S82D-3005	14 mm ² min.	30 cm max.
	8 mm ² min.	20 cm max.
S82D-3012	8 mm ² min.	30 cm max.
	5.5 mm ² min.	20 cm max.
S82D-3024	8 mm ² min.	50 cm max.
	5.5 mm ² min.	30 cm max.
S82D-6005	20 mm ² min.	30 cm max.
	14 mm ² min. (2 wires min.)	30 cm max.
S82D-6012	14 mm ² min.	30 cm max.
	8 mm ² min. (2 wires min.)	30 cm max.
S82D-6024	8 mm ² min.	30 cm max.
	5.5 mm ² min. (2 wires min.)	30 cm max.

Adjusting the Output Voltage

Follow the procedure below when adjusting the output voltage of a master/slave system.

1. Connect the two Power Supplies in parallel and decide which unit will be the master.
2. Turn the voltage adjuster (V. ADJ) of the slave unit all the way clockwise.
3. Adjust the voltage adjuster (V. ADJ) of the master unit to the desired voltage.
4. Slowly turn the voltage adjuster (V. ADJ) of the slave unit counterclockwise and set value just before output voltage drop.

NOTICE

1. It is recommended to set equal output voltages to both Power Supplies for safety reasons. If the master Power Supply stops operation by input failure or breakage, the set output value of the slave Power Supply will be output.
2. Even if one Power Supply fails to operate, both output LED indicators may be lit if the other Power Supply is in operation.