

Typical Applications

- 3V CDMA/AMPS Cellular Handsets
- Spread-Spectrum Systems

Product Description

The RF3105 is a high-power, high-efficiency linear amplifier IC targeting 3V handheld systems. The device is manufactured on an advanced Gallium Arsenide Hetero-junction Bipolar Transistor (HBT) process, and has been designed for use as the final RF amplifier in dual-mode 3V CDMA/AMPS handheld digital cellular equipment, spread-spectrum systems, and other applications in the 824MHz to 849MHz band. The RF3105 has a digital bias control voltage for low current in standby mode. The device is self-contained with 50Ω input and output that is matched to obtain optimum power, efficiency, and linearity characteristics. The module is an ultra-small 6mmx6mm land grid array with backside ground.

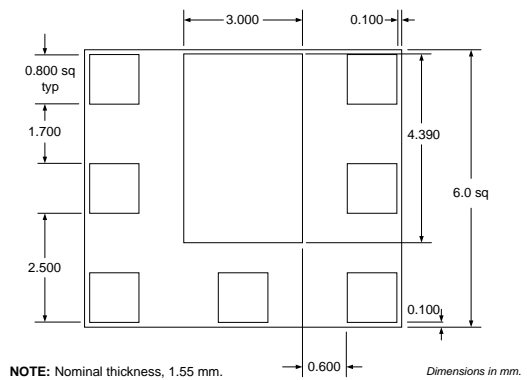

Optimum Technology Matching® Applied

- | | | |
|-------------------------------------|--|--------------------------------------|
| <input type="checkbox"/> Si BJT | <input checked="" type="checkbox"/> GaAs HBT | <input type="checkbox"/> GaAs MESFET |
| <input type="checkbox"/> Si Bi-CMOS | <input type="checkbox"/> SiGe HBT | <input type="checkbox"/> Si CMOS |

Package Style: LGM (6mmx6mm)

Features

- Input/Output Internally Matched @ 50Ω
- Single 3V Supply
- 29dBm Linear Output Power
- 28dB Linear Gain
- 35% Linear Efficiency

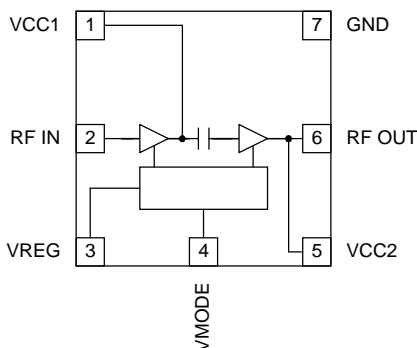

Functional Block Diagram

Ordering Information

- | | |
|-------------|-----------------------------------|
| RF3105 | 3V 900MHz Linear Amplifier Module |
| RF3105 PCBA | Fully Assembled Evaluation Board |

RF Micro Devices, Inc.
7625 Thorndike Road
Greensboro, NC 27409, USA

Tel (336) 664 1233
Fax (336) 664 0454
<http://www.rfmd.com>

Absolute Maximum Ratings

Parameter	Rating	Unit
Supply Voltage (RF off)	+8.0	V _{DC}
Supply Voltage (P _{OUT} ≤31 dBm)	+4.5	V _{DC}
Control Voltage (V _{REG})	+4.2	V _{DC}
Input RF Power	+10	dBm
Mode Voltage (V _{MODE})	+3.5	V _{DC}
Operating Ambient Temperature	-30 to +85	°C
Storage Temperature	-30 to +150	°C



Caution! ESD sensitive device.

RF Micro Devices believes the furnished information is correct and accurate at the time of this printing. However, RF Micro Devices reserves the right to make changes to its products without notice. RF Micro Devices does not assume responsibility for the use of the described product(s).

Parameter	Specification			Unit	Condition
	Min.	Typ.	Max.		
Overall					T=25°C Ambient, V _{CC} =3.4V, V _{REG} =2.75V, V _{MODE} =0, Freq=824MHz to 849MHz unless otherwise specified
Frequency Range	824		849	MHz	
Linear Gain	27	29	32.5	dB	
Second Harmonic			-30	dBc	
Third Harmonic			-40	dBc	
Maximum Linear Output Power (CDMA Modulation)	28	29		dBm	
Total Linear Efficiency	32	35		%	
Adjacent Channel Power Rejection			-44	dBc	ACPR @ 885kHz
		-58	-56	dBc	ACPR @1980kHz
Input VSWR		<2:1			
Output VSWR			10:1		No damage.
			6:1		No oscillations.
Noise Figure			8	dB	
Noise Power			-89	dBm/30kHz	At 45MHz offset.
FM Mode					
Frequency Range	824		849	MHz	
Second Harmonic			-30	dBc	
Third Harmonic			-40	dBc	
Max CW Output Power		31.5	32	dBm	
Total Efficiency (AMPS)		45		%	V _{CC} =3.4V, P _{OUT} =31.5dBm
Large Signal Gain	27			dB	
Input VSWR		<2:1			
Output VSWR		10:1			No damage.
		6:1			No oscillations.
Power Supply					
Power Supply Voltage	3.2	3.4	4.5	V	
Quiescent Current		100		mA	
V _{REG} Current			8	mA	Pin 3, V _{REG} =2.75V
Turn On/Off time			40	µs	
Total Current (Power down)			10	µA	V _{REG} =Low
V _{REG} "Low" Voltage		0	0.2	V	
V _{REG} "High" Voltage	2.65	2.75	2.85	V	

Pin	Function	Description	Interface Schematic
1	VCC1	First stage collector supply. A low frequency decoupling capacitor (e.g., 4.7 μ F) is required.	
2	RF IN	RF input internally matched to 50 Ω . This input is internally AC coupled.	
3	VREG	Regulated voltage supply for amplifier bias.	
4	VMODE	For nominal operation, V _{MODE} is set to LOW. When set HIGH: V _{MODE} will increase the bias current by approximately 50%; and, large signal gain is increased by approximately 1.5dB.	
5	VCC2	Output stage collector supply. A low frequency decoupling capacitor (e.g., 4.7 μ F) is required.	
6	RF OUT	RF output internally matched to 50 Ω . This output is internally AC coupled.	
7	GND	Ground connection. Connect to package base ground. For best performance, keep traces physically short and connect immediately to ground plane.	
Pkg Base	GND	Ground connection. The backside of the package should be soldered to a top side ground pad which is connected to the ground plane with multiple vias. The pad should have a short thermal path to the ground plane.	

Evaluation Board Schematic

(Download [Bill of Materials](http://www.rfmd.com) from www.rfmd.com.)

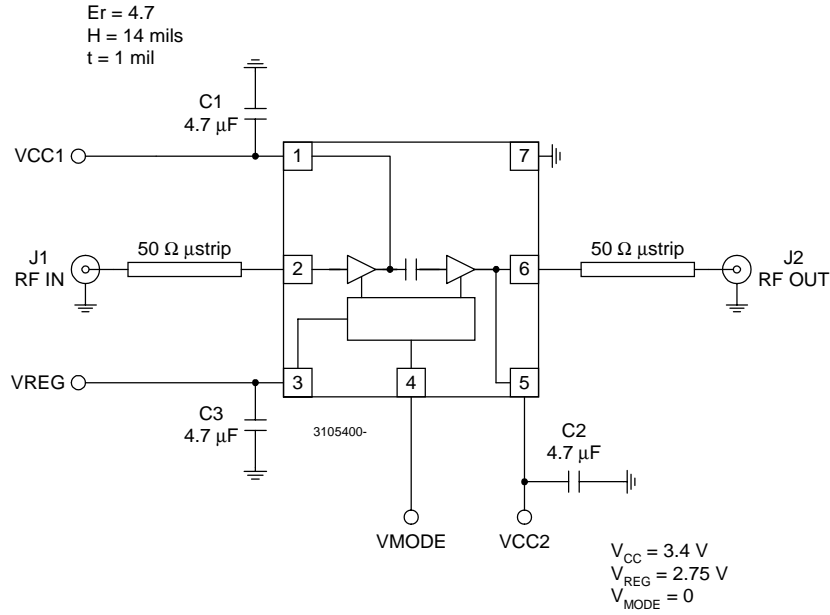

Evaluation Board Layout Board Size 2.0" x 2.0"

Board Thickness 0.028", Board Material FR-4, Multi-Layer
Assembly Top

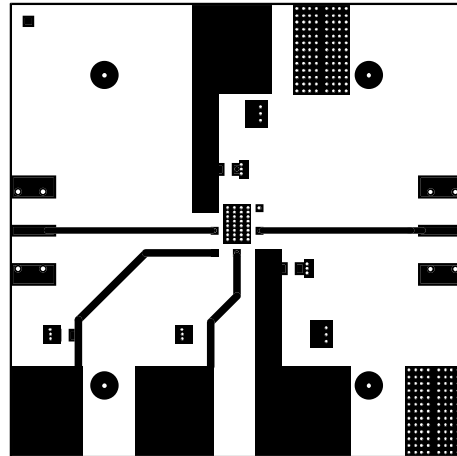
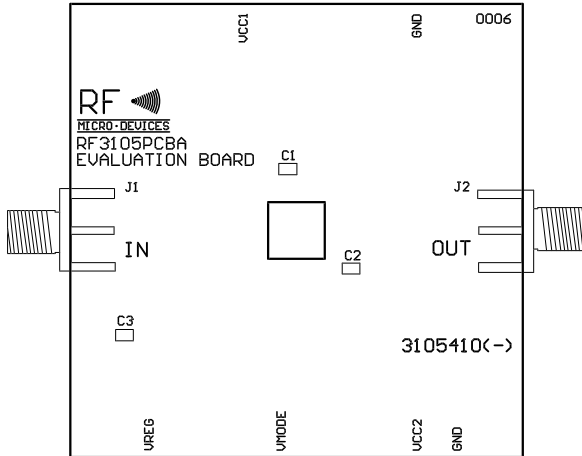

Inner 1

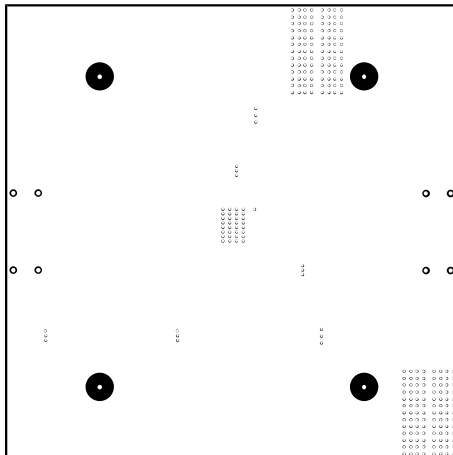

Back

