

PT481/PT481F/ PT483F1

■ Features

1. Epoxy resin package
2. Narrow acceptance ($\Delta\theta$: Typ. $\pm 13^\circ$)
3. High sensitivity

(I_c : MIN. 1.5mA at $E_e = 0.1\text{mW}/\text{cm}^2$) :

PT481/PT483F1

(I_c : MIN. 0.9mA at $E_e = 0.1\text{mW}/\text{cm}^2$) :

PT481F

4. Visible light cut-off type : **PT481F/PT483F1**
5. Long lead pin type : **PT483F1**

■ Applications

1. VCRs, cassette tape recorders
2. Floppy disk drives
3. Optoelectronic switches
4. Automatic stroboscopes

■ Absolute Maximum Ratings (Ta = 25°C)

Parameter	Symbol	Rating	Unit
Collector-emitter voltage	V_{CEO}	35	V
Emitter-collector voltage	V_{ECO}	6	V
Collector current	I_c	50	mA
Collector power dissipation	P_c	75	mW
Operating temperature	T_{opr}	-25 to +85	°C
Storage temperature	T_{stg}	-40 to +85	°C
*Soldering temperature	T_{sol}	260	°C

*1 For 3 seconds at the position of 1.4mm from the bottom face of resin package

Narrow Acceptance High Sensitivity Phototransistor

■ Outline Dimensions

(Unit : mm)

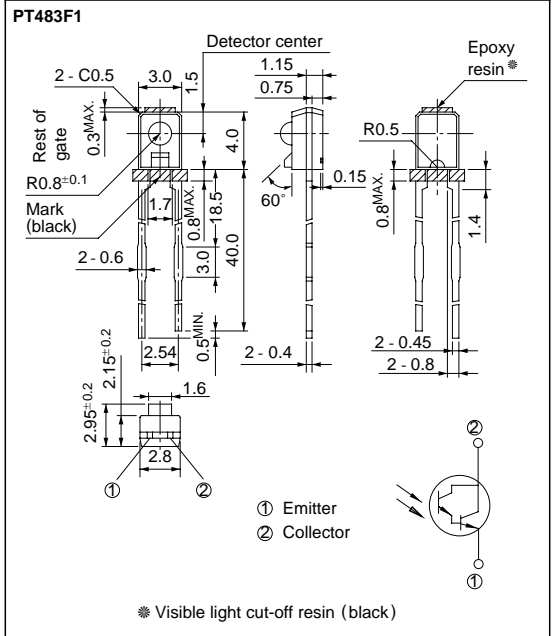
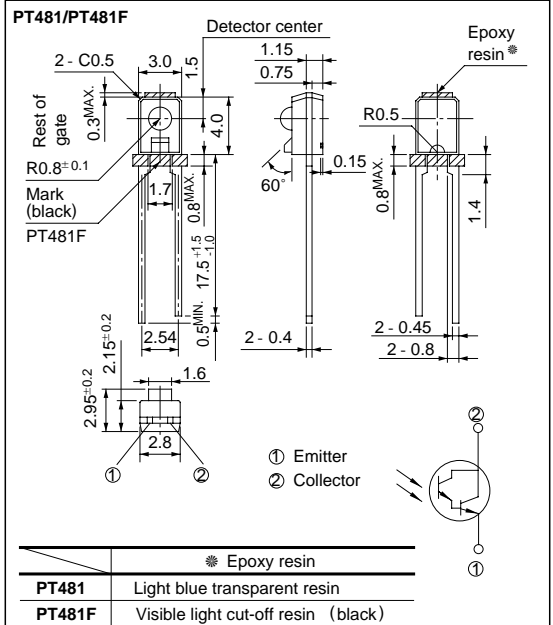

Electro-optical Characteristics

($T_a = 25^\circ\text{C}$)

Parameter		Symbol	Conditions	MIN.	TYP.	MAX.	Unit
*2 Collector current	PT481	I_C	$V_{CE} = 2\text{V}$ $E_e = 0.1\text{mW/cm}^2$	1.5	10	25	mA
	PT481F			0.9	-	27	mA
	PT483F1			1.5	-	4.0	mA
Collector dark current		I_{CEO}	$V_{CE} = 10\text{V}, E_e = 0$	-	-	10^{-6}	A
*2 Collector-emitter saturation voltage		$V_{CE(sat)}$	$I_C = 2.5\text{mA}$ $E_e = 1\text{mW/cm}^2$	-	0.7	1.0	V
Peak emission wavelength	PT481	λ_p	-	-	800	-	nm
	PT481F/PT483F1			-	860	-	nm
Response time	Rise time	t_r	$V_{CE} = 2\text{V}, I_C = 10\text{mA}$	-	80	-	μs
	Fall time	t_f	$R_L = 100\Omega$	-	70	-	μs

*2 E_e : Irradiance by CIE standard light source A (tungsten lamp)

Fig. 1 Collector Power Dissipation vs. Ambient Temperature

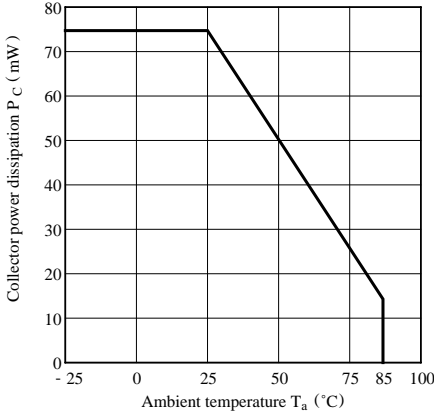

Fig. 2 Collector Dark Current vs. Ambient Temperature

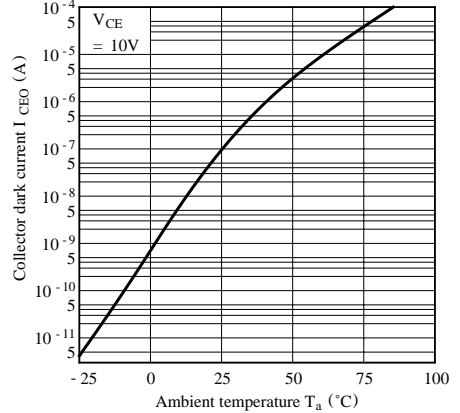

Fig. 3 Relative Collector Current vs. Ambient Temperature

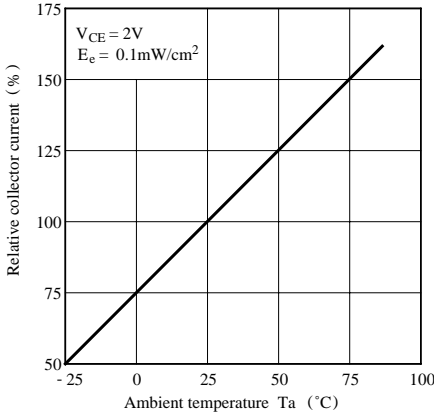

Fig.4-a Collector Current vs. Irradiance (PT481)

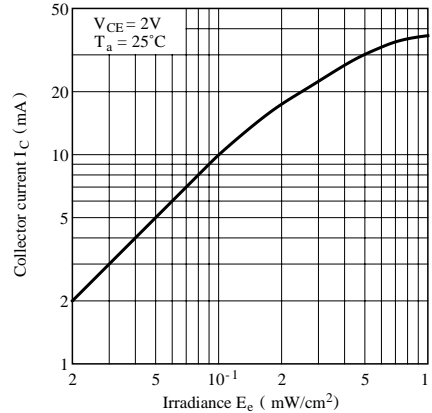

Fig.4-b Collector Current vs. Irradiance
(PT481F/PT483F1)

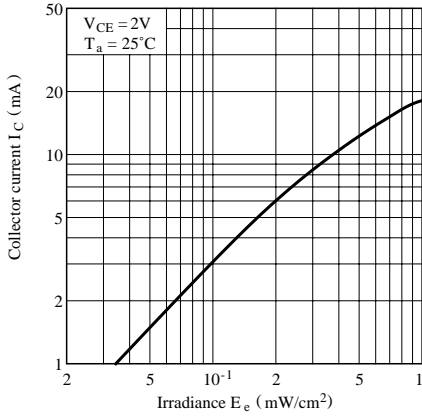

Fig.5-a Current vs. Collector-emitter Voltage
(PT481)

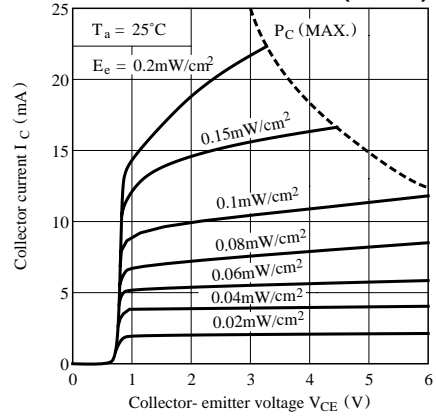

Fig.5-b Collector Current vs. Collector-emitter Voltage
(PT481F/PT483F1)

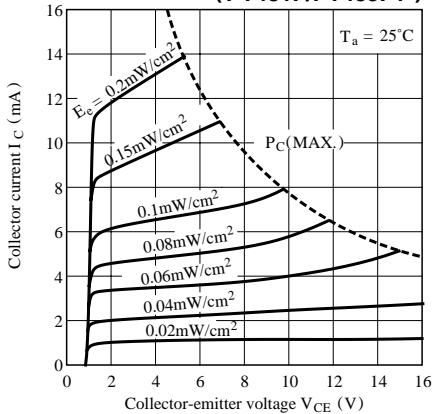

Fig. 6 Spectral Sensitivity

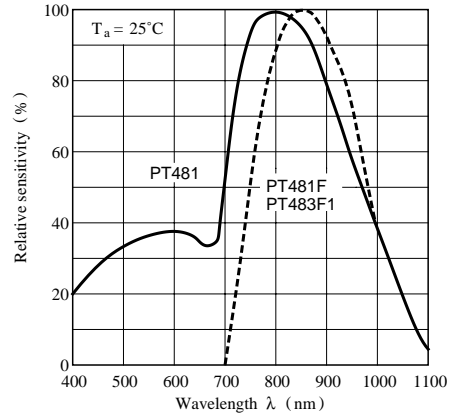
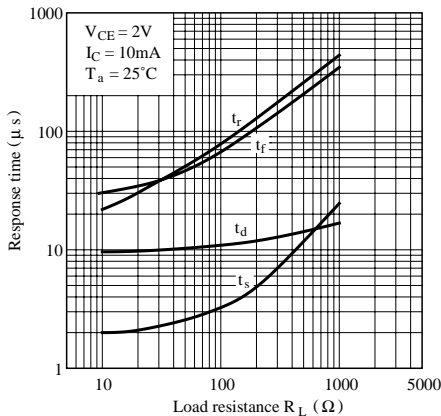

Fig. 7 Response Time vs. Load Resistance



Test Circuit for Response Time

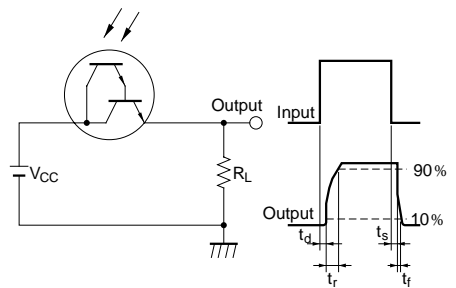

Fig. 8 Sensitivity Diagram

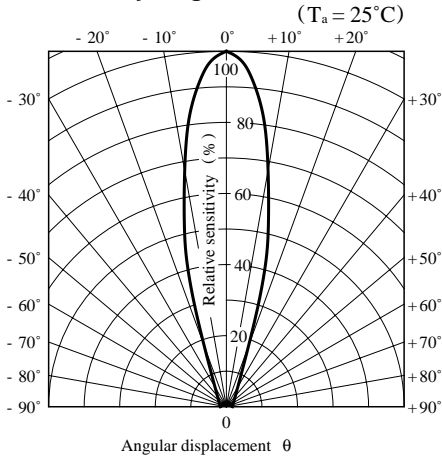

Fig.9-a Collector-emitter Saturation Voltage vs. Irradiance (PT481)

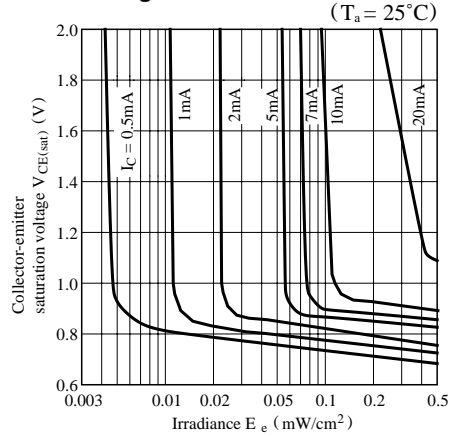

Fig.9-b Collector-emitter Saturation Voltage vs. Irradiance (PT481F/PT483F1)

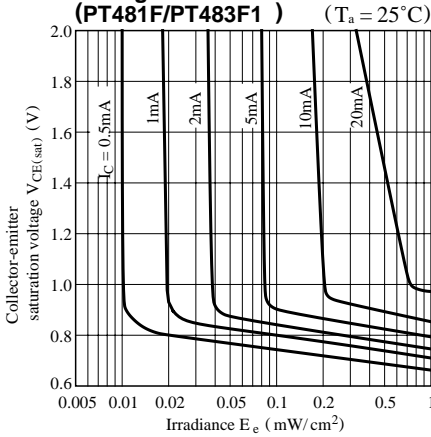
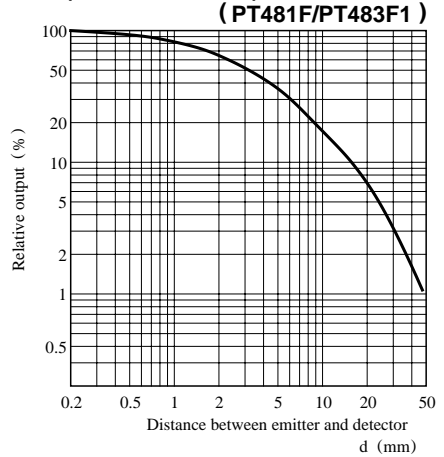

Fig.10 Relative Output vs. Distance (Emitter : GL480)



● Please refer to the chapter “Precautions for Use.”