

Three Terminal Low Current Positive Voltage Regulators

PL78L06XA3

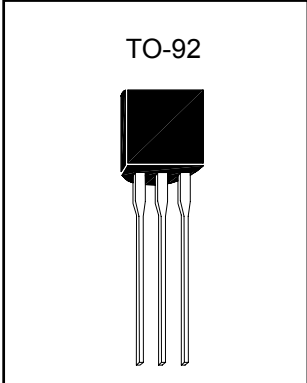

Description

These regulators employ internal current-limiting and thermal-shutdown, making them essentially indestructible. They can deliver up to 100mA output current, if the case temperature can keep in $T_c=25^{\circ}\text{C}$. They are intended as fixed voltage regulators in a wide range of applications including local (on-card) regulation for elimination of noise and distribution problems associated with single-point regulation. In addition, they can be used with power pass elements to make high-current voltage regulators. The PL78L06 used as a Zener diode/resistor combination replacement, offers an effective output impedance improvement of typically two orders of magnitude, along with lower quiescent current and lower noise.

Absolute Maximum Ratings ($T_a=25^{\circ}\text{C}$)

- Input Voltage..... 35 V
- Total Power Dissipation..... Internally limited
- Operating Temperature Range..... 0°C to $+125^{\circ}\text{C}$
- Maximum Junction Temperature..... 125°C
- Storage Temperature Range..... -55°C to $+150^{\circ}\text{C}$
- Lead Temperature (Soldering 10S)..... 260°C

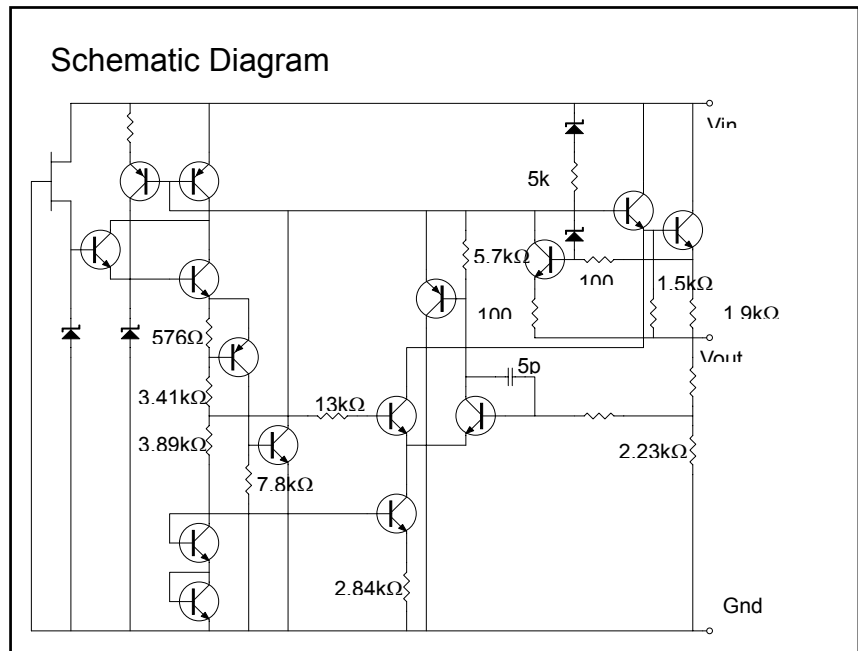
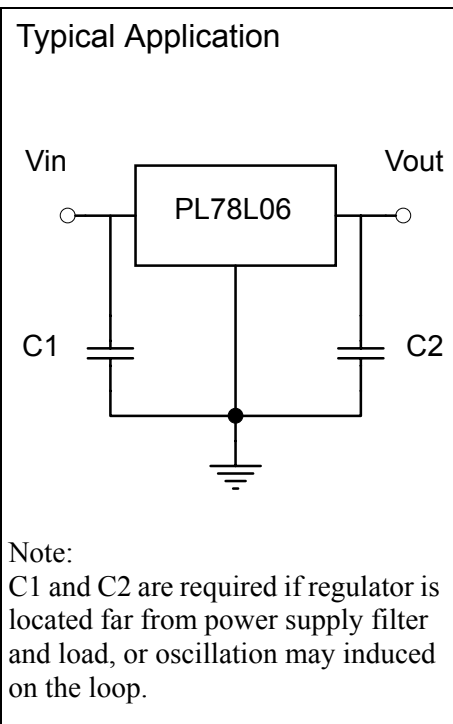



Ordering Information

Device	Output Voltage Tolerance
PL78L06AA3	3%
PL78L06BA3	5%

Electrical Characteristics

$V_{in}=11V$, $I_{out}=40mA$, $0^{\circ}C \leq T_j \leq 125^{\circ}C$, $C_{in}=0.33\mu F$, $C_{out}=0.1\mu F$ (unless otherwise noted)

Symbol	Parameter	Conditions	PL78L06A			Units
			Min	Typ	Max	
Vo	Output Voltage	Tj=25°C	5.82	6	6.18	V
		1mA ≤ Io ≤ 70mA	5.82	-	6.18	
		1mA ≤ Io ≤ 40mA and 8V ≤ Vin ≤ 21V	5.82	-	6.18	
ΔVo	Line Regulation	Tj=25°C, 8V ≤ Vin ≤ 21V	-	65	175	mV
		Tj=25°C, 9V ≤ Vin ≤ 21V	-	55	125	
ΔVo	Load Regulation	Tj=25°C, 1mA ≤ Io ≤ 40mA	-	6	40	mV
		Tj=25°C, 1mA ≤ Io ≤ 100mA	-	13	80	
IQ	Quiescent Current	Tj=25°C	-	-	5.5	mA
ΔIQ	Quiescent Current Change	1mA ≤ Io ≤ 40mA	-	-	0.1	mA
		9V ≤ Vin ≤ 21V	-	-	1.5	
Vn	Output Noise Voltage	Ta=25°C, 10Hz ≤ f ≤ 10KHz	-	45	-	uV
ΔVin / ΔVout	Ripple Rejection	9V ≤ Vin ≤ 18V, f=120Hz	44	59	-	dB
Isc	Peak Output / Short Circuit Current	Tj=25°C	-	140	-	mA
VD	Dropout Voltage	Tj=25°C	-	1.7	-	V

Symbol	Parameter	Conditions	PL78L06B			Units
			Min	Typ	Max	
Vo	Output Voltage	Tj=25°C	5.75	6	6.25	V
		1mA ≤ Io ≤ 70mA	5.7	-	6.3	
		1mA ≤ Io ≤ 40mA and 8V ≤ Vin ≤ 21V	5.7	-	6.3	
ΔVo	Line Regulation	Tj=25°C, 8V ≤ Vin ≤ 21V	-	65	175	mV
		Tj=25°C, 9V ≤ Vin ≤ 21V	-	55	125	
ΔVo	Load Regulation	Tj=25°C, 1mA ≤ Io ≤ 40mA	-	6	40	mV
		Tj=25°C, 1mA ≤ Io ≤ 100mA	-	13	80	
IQ	Quiescent Current	Tj=25°C	-	-	5.5	mA
ΔIQ	Quiescent Current Change	1mA ≤ Io ≤ 40mA	-	-	0.1	mA
		9V ≤ Vin ≤ 21V	-	-	1.5	
Vn	Output Noise Voltage	Ta=25°C, 10Hz ≤ f ≤ 10KHz	-	45	-	uV
ΔVin / ΔVout	Ripple Rejection	9V ≤ Vin ≤ 18V, f=120Hz	44	59	-	dB
Isc	Peak Output / Short Circuit Current	Tj=25°C	-	140	-	mA
VD	Dropout Voltage	Tj=25°C	-	1.7	-	V

Characteristic Curves

Dropout Characteristics

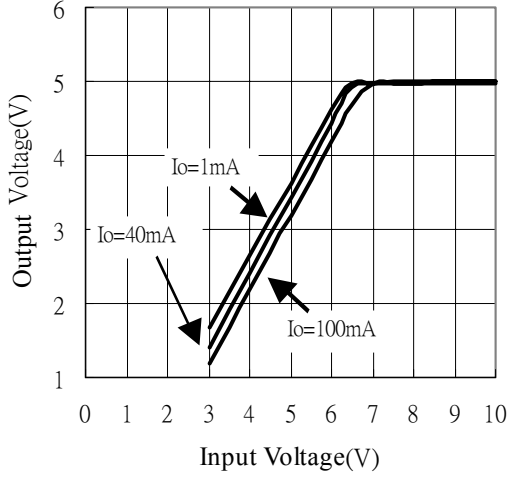

Maximum Average Power Dissipation

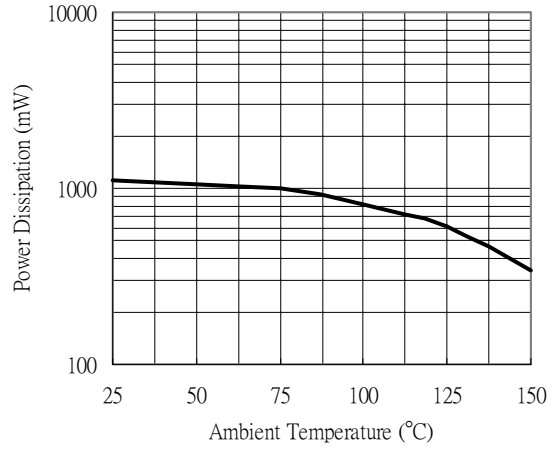

Quiescent Current

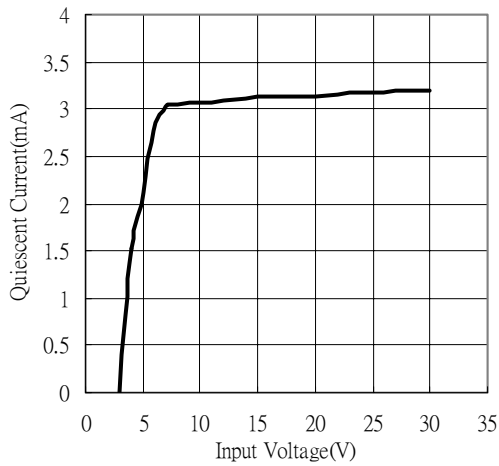

Quiescent Current

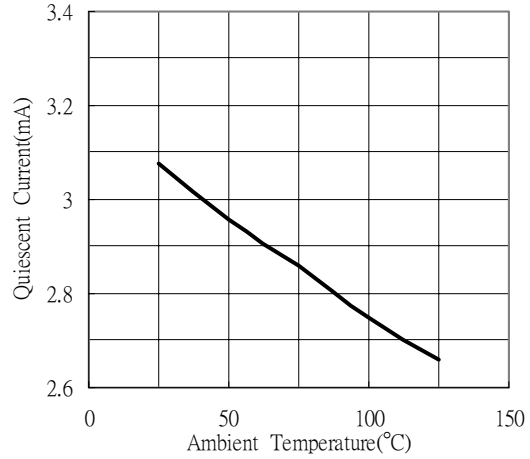

TO-92 Dimension

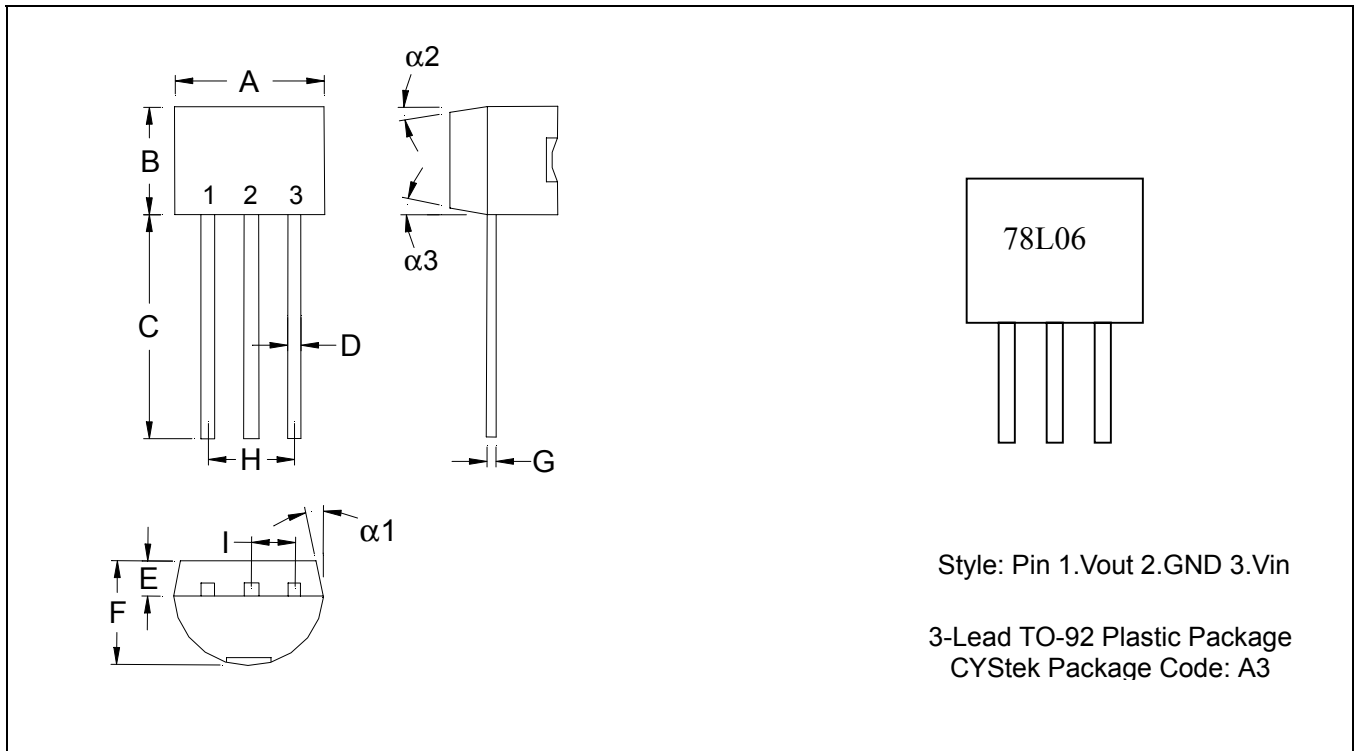

*: Typical

DIM	Inches		Millimeters		DIM	Inches		Millimeters	
	Min.	Max.	Min.	Max.		Min.	Max.	Min.	Max.
A	0.1704	0.1902	4.33	4.83	G	0.0142	0.0220	0.36	0.56
B	0.1704	0.1902	4.33	4.83	H	-	*0.1000	-	*2.54
C	0.5000	-	12.70	-	I	-	*0.0500	-	*1.27
D	0.0142	0.0220	0.36	0.56	alpha1	-	*5°	-	*5°
E	-	*0.0500	-	*1.27	alpha2	-	*2°	-	*2°
F	0.1323	0.1480	3.36	3.76	alpha3	-	*2°	-	*2°

Notes: 1.Controlling dimension: millimeters.
 2.Maximum lead thickness includes lead finish thickness, and minimum lead thickness is the minimum thickness of base material.
 3.If there is any question with packing specification or packing method, please contact your local CYStek sales office.

Material:

- Lead: 42 Alloy ; solder plating
- Mold Compound: Epoxy resin family, flammability solid burning class: UL94V-0

Important Notice:

- All rights are reserved. Reproduction in whole or in part is prohibited without the prior written approval of CYStek.
- CYStek reserves the right to make changes to its products without notice.
- CYStek **semiconductor products are not warranted to be suitable for use in Life-Support Applications, or systems.**
- CYStek assumes no liability for any consequence of customer product design, infringement of patents, or application assistance.