

20-Bit, 2-Port Bus Switch with Undershoot Protection

Product Features

- Near-zero propagation delay
- 5Ω switches connect inputs to outputs
- Undershoot Protection up to -1V
- Direct bus connection when switches are ON
- 32X384 function with flow through pinout make board layout easier
- Ultra-low quiescent power (120μA typical)
— ideally suited for notebook applications
- Industrial operating temperature: -40°C to +85°C
- Packages available:
 - 48-pin 240-mil wide plastic TSSOP (A)
 - 48-pin 150-mil wide plastic BQSOP (B)

Product Description

Pericom Semiconductor's PI5C series of Bus Switch circuits are produced using the Company's advanced submicron CMOS technology, achieving industry leading speed.

The PI5C16862C is configured as a 20-bit, 2-port bus switch designed with a low ON resistance (5Ω) allowing inputs to be connected directly to outputs. The bus switch creates no additional propagational delay or additional ground bounce noise. The switches are turned ON by the Bus Enable (\overline{BE}_x) input signal.

The PI5C16862C can withstand undershoot of up to -1V.

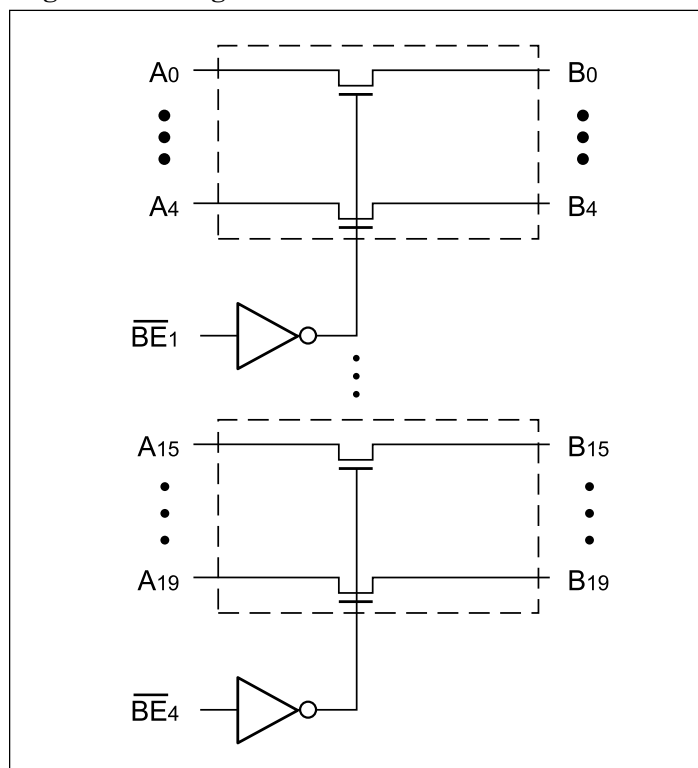
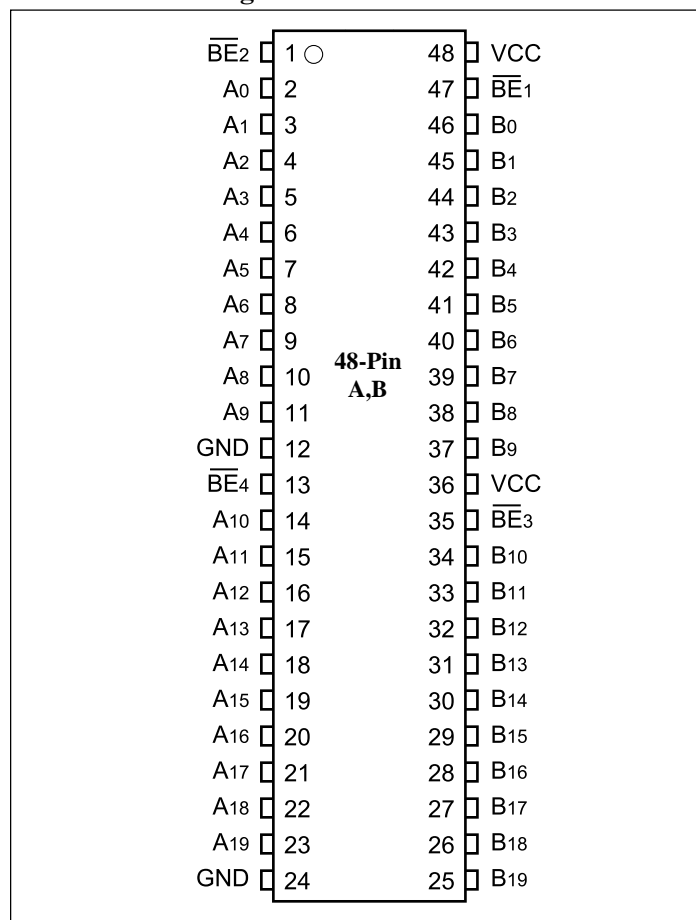
Logic Block Diagram

Product Pin Configuration

Truth Table⁽¹⁾

Function	\overline{BE}_x	A19-A0
Disconnect	H	Hi-Z
Connect	L	B19-B0

Note:

1. H = High Voltage Level
L = Low Voltage Level
Hi-Z = High Impedance

Product Pin Description

Pin Name	Description
\overline{BE}_x	Bus Enable Inputs (Active LOW)
A19-A0	Bus A
B19-B0	Bus B

Maximum Ratings

(Above which the useful life may be impaired. For user guidelines, not tested.)

Storage Temperature	-65°C to +150°C
Ambient Temperature with Power Applied	-40°C to +85°C
Supply Voltage to Ground Potential (Inputs & V _{CC} Only) ...	-0.5V to +7.0V
Supply Voltage to Ground Potential (Outputs & D/O Only) .	-0.5V to +7.0V
DC Input Voltage	-0.5V to +7.0V
DC Output Current	120mA
Power Dissipation	0.5W

Note:

Stresses greater than those listed under MAXIMUM RATINGS may cause permanent damage to the device. This is a stress rating only and functional operation of the device at these or any other conditions above those indicated in the operational sections of this specification is not implied. Exposure to absolute maximum rating conditions for extended periods may affect reliability.

DC Electrical Characteristics (Over the Operating Range, T_A = -40°C to +85°C, V_{CC} = 5V ±10%)

Parameters	Description	Test Conditions ⁽¹⁾	Min.	Typ. ⁽²⁾	Max.	Units
V _{IH}	Input HIGH Voltage	Guaranteed Logic HIGH Level	2.0	—	—	V
V _{IL}	Input LOW Voltage	Guaranteed Logic LOW Level	-0.5	—	0.8	V
I _{IH}	Input HIGH Current	V _{CC} = Max., V _{IN} = V _{CC}	—	—	±1	μA
I _{IL}	Input LOW Current	V _{CC} = Max., V _{IN} = GND	—	—	±1	μA
I _{OZH}	High Impedance Output Current	0 ≤ A, B ≤ V _{CC}	—	—	±1	μA
V _{IK}	Clamp Diode Voltage	V _{CC} = Min., I _{IN} = -18mA	—	—	-1.8	V
I _{OS}	Short Circuit Current ⁽³⁾	A (B) = 0V, B (A) = V _{CC}	100	—	—	mA
V _H	Input Hysteresis at Control Pins		—	150	—	mV
R _{ON}	Switch On Resistance ⁽⁴⁾	V _{CC} = Min., V _{IN} = 0.0V, I _{ON} = 48mA	—	5.5	8	Ω
		V _{CC} = Min., V _{IN} = 2.4V, I _{ON} = 15mA	—	9	16	

Capacitance (T_A = 25°C, f = 1 MHz)

Parameters ⁽⁵⁾	Description	Test Conditions	Typ.	Units
C _{IN}	Input Capacitance	V _{IN} = 0V	6	pF
C _{OFF}	A/B Capacitance, Switch Off	V _{IN} = 0V	6	pF
C _{ON}	A/B Capacitance, Switch On	V _{IN} = 0V	10	pF

Notes:

1. For Max. or Min. conditions, use appropriate value specified under Electrical Characteristics for the applicable device type.
2. Typical values are at V_{CC} = 5.0V, T_A = 25°C ambient and maximum loading.
3. Not more than one output should be shorted at one time. Duration of the test should not exceed one second.
4. Measured by the voltage drop between A and B pin at indicated current through the switch. ON resistance is determined by the lower of the voltages on the two (A,B) pins.
5. This parameter is determined by device characterization but is not production tested.

Power Supply Characteristics

Parameters	Description	Test Conditions ⁽¹⁾		Min.	Typ. ⁽²⁾	Max.	Units
I _{CC}	Quiescent Power Supply Current	V _{CC} = Max.	V _{IN} = GND or V _{CC}		120	200	μA
ΔI _{CC}	Supply Current per Input @ TTL HIGH	V _{CC} = Max.	V _{IN} = 3.4V ⁽³⁾			2.5	mA
I _{CCD}	Supply Current per Input per MHz ⁽⁴⁾	V _{CC} = Max., A and B Pins Open \overline{BEx} = GND Control Input Toggling 50% Duty Cycle				0.25	mA/ MHz

Notes:

1. For Max. or Min. conditions, use appropriate value specified under Electrical Characteristics for the applicable device.
2. Typical values are at V_{CC} = 5.0V, +25°C ambient.
3. Per TTL driven input (V_{IN} = 3.4V, control inputs only); A and B pins do not contribute to I_{CC}.
4. This current applies to the control inputs only and represent the current required to switch internal capacitance at the specified frequency. The A and B inputs generate no significant AC or DC currents as they transition. This parameter is not tested, but is guaranteed by design.

PI5C16862 Switching Characteristics over Operating Range

Parameters	Description	Conditions ⁽¹⁾	PI5C16862C		Units
			Com.		
			Min.	Max.	
t _{PLH}	Propagation Delay ^(2,3) Ax to Bx, Bx to Ax	C _L = 50pF R _L = 500Ω		0.25	ns
t _{PHL}					
t _{PZH}	Bus Enable Time \overline{BEx} to Ax or Bx		1.5	6.5	
t _{PZL}					
t _{PHZ}	Bus Disable Time BEx to Ax or Bx		1.5	5.5	
t _{PLZ}					

Notes:

1. See test circuit and waveforms.
2. This parameter is guaranteed but not tested on Propagation Delays.
3. The bus switch contributes no propagational delay other than the RC delay of the ON resistance of the switch and the load capacitance. The time constant for the switch alone is of the order of 0.25ns for 50pF load. Since this time constant is much smaller than the rise/fall times of typical driving signals, it adds very little propagational delay to the system. Propagational delay of the bus switch when used in a system is determined by the driving circuit on the driving side of the switch and its interaction with the load on the driven side.