

<p>TECHNICAL SPECIFICATION</p> <p>MODEL NO. : PD035OX1</p>
--

Customer's Confirmation

Customer _____

By _____

PVI's Confirmation

Confirmed By _____

Prepared By _____

FOR MORE INFORMATION:

AZ DISPLAYS, INC.
75 COLUMBIA, ALISO VIEJO, CA, 92656
[Http://www.AZDISPLAYS.com](http://www.AZDISPLAYS.com)

Date: Jun. 07, 2005

This technical specification is subject to change without notice.
Please return 1 copy with your signature on this page for approval.

TECHNICAL SPECIFICATION***CONTENTS***

<i>NO.</i>	<i>ITEM</i>	<i>PAGE</i>
-	Cover	1
-	Contents	2
1	Application	3
2	Features	3
3	Mechanical Specifications	3
4	Mechanical Drawing of TFT-LCD module	4
5	Input / Output Terminals	5
6	Pixel Arrangement and Input Connector Pin NO	13
7	SPI Register Description and Timing Characteristics	14
8	Absolute Maximum Ratings	18
9	Electrical Characteristics	18
10	Power On Sequence	25
11	Optical Characteristics	25
12	Handling Cautions	28
13	Reliability Test	29
14	Block Diagram	30
15	Packing	31
-	Revision History	32
-	Appendix	33

1. Application

This technical specification applies to 3.5” color TFT-LCD panel PD035OX1.

The TFT LCD panel applies to videophone, door phone and other electronic products which require high quality flat panel displays.

2. Features

- . Amorphous silicon TFT-LCD panel with LED Backlight unit
- . Support digital 8-bits serial / 24-bits parallel RGB and CCIR601/656 input mode.
- . OSD overlay supported in CCIR601/656 input mode.
- . Optimum viewing direction : 6 o'clock.
- . Provide source and gate drivers control timing.
- . Image Reversion : Up/Down and Left/Right

3. Mechanical Specifications

Parameter	Specifications	Unit
Screen Size	3.5 (diagonal)	inch
Display Format	960 x 234	dot
Active Area	71.6 (H)×52.65 (V)	mm
Dot Pitch	0.0745 (H)×0.225 (V)	mm
Pixel Configuration	Delta	
Outline Dimension	84.15 (W)×65.3 (H)×3.45 (D)	mm
Surface Treatment	Anti – Glare	
Weight	42±4	g

4. Mechanical Drawing of TFT-LCD Module

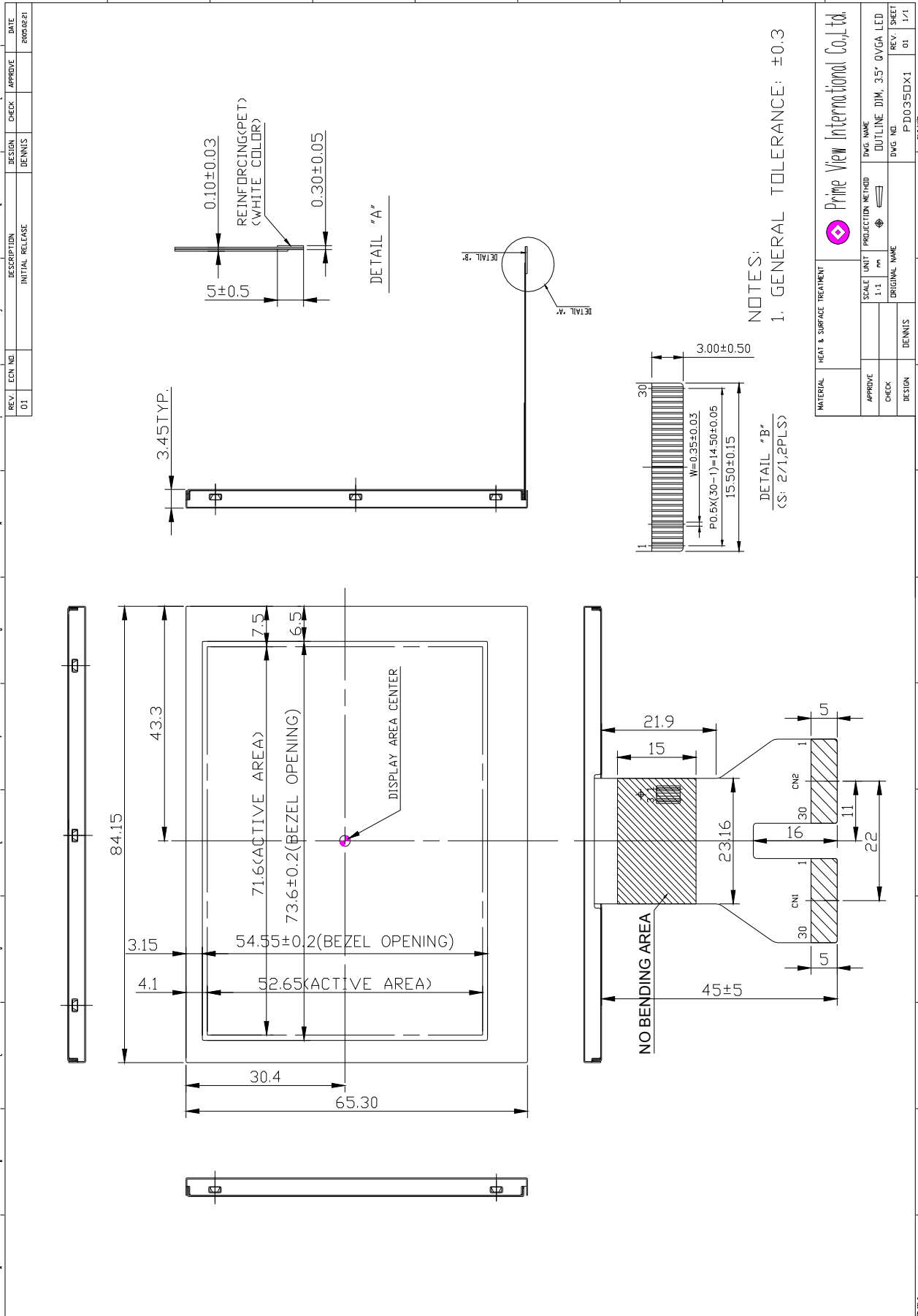

5. Input / Output Terminals
CON2

FPC Down Connect , 30Pins , Pitch : 0.5 mm

Pin No	Symbol	I/O	Description	Remark
1	VLED	I	Power supply for LED	Note 5-1
2	GLED1	I	Ground for LED	
3	GLED2	I	Ground for LED	
4	NC	-	NC	
5	VGH	I	Positive power for gate driver	Note 5-2
6	VDD1	I	Power supply for gate logic circuit	Note 5-3
7	VSS1	I	Ground for gate driver	
8	VEE	I	Negative power for gate driver	Note 5-4
9	VDD1	I	Power supply for gate logic circuit	Note 5-3
10	GND	I	Digital ground for source driver IC	
11	RESETB	I	Hardware global reset, (low active)	
12	VSET		Externally/Internally gamma voltage setup	
13	U/D	I	Up/Down control for gate driver	Note 5-9
14	L/R	I	Left/Right control for source driver	
15	IF1	I	Select the input data format (Serial RGB, Parallel RGB, CCIR601/656)	Note 5-10
16	IF2	I		
17	SPENA	I	Serial port data enable signal (normally pull high)	
18	SPCK	I	Serial port clock. (Normally pull high)	
19	SPDA	I/O	Serial port data input/output	
20	POL	O	Polarity select for the line inversion control signal	Note 5-11
21	D27(B7)	I	Blue Data(MSB)	Note 5-12
22	D26(B6)	I	Blue Data	
23	D25(B5)	I	Blue Data	
24	D24(B4)	I	Blue Data	
25	D23(B3)	I	Blue Data	
26	D22(B2)	I	Blue Data	
27	D21(B1)	I	Blue Data	
28	D20(B0)	I	Blue Data(LSB)	
29	D17(G7)	I	Green Data(MSB)	
30	D16(G6)	I	Green Data	

CON1

FPC Down Connect , 30Pins , Pitch : 0.5 mm

Pin No	Symbol	I/O	Description	Remark
1	D15(G5)	I	Green Data	Note 5-11
2	D14(G4)	I	Green Data	
3	D13(G3)	I	Green Data	
4	D12(G2)	I	Green Data	
5	D11(G1)	I	Green Data	
6	D10(G0)	I	Green Data(LSB)	
7	VDD2	I	Analog power supply for source driver	Note 5-5
8	V8	I	Gamma correction voltage 8	Note 5-15
9	V7	I	Gamma correction voltage 7	
10	V6	I	Gamma correction voltage 6	
11	V5	I	Gamma correction voltage 5	
12	V4	I	Gamma correction voltage 4	
13	V3	I	Gamma correction voltage 3	
14	V2	I	Gamma correction voltage 2	
15	V1	I	Gamma correction voltage 1	
16	VSS2	I	Analog ground for source driver	
17	D07(R7)	I	Red Data(MSB)	Note 5-11
18	D06(R6)	I	Red Data	
19	D05(R5)	I	Red Data	
20	D04(R4)	I	Red Data	
21	D03(R3)	I	Red Data	
22	D02(R2)	I	Red Data	
23	D01(R1)	I	Red Data	
24	D00(R0)	I	Red Data(LSB)	
25	CLK	I	Clock signal. Latching data at the rising edge	
26	HS	I	Horizontal sync input in RGB mode and CCIR601	Note 5-13
27	VS	I	Vertical sync input in RGB mode and CCIR601	Note 5-14
28	DEN	I	Input data enable control.(Normally pull low)	
29	VCC	I	Digital power supply for source driver IC	Note 5-6
30	VCOM	I	Voltage for common electrode	Note 5-7

Note 5-1 : ILED Typ. = 20mA.

Note 5-2 : V_{GH} Typ. = +15V.

Note 5-3 : V_{DD1} Typ. = +3.3V.

Note 5-4 : V_{EE} Typ. = -15V.

Note 5-5 : V_{DD2} Typ. = +5V.

Note 5-6 : V_{CC} Typ. = +3.3V.

Note 5-7 : V_{COM} Typ. = +6.0V_{pp}.

Note 5-9 : The definition of L/R , U/D

U/D(PIN 13)=Low L/R(PIN 14)=High

U/D(PIN 13)=High L/R(PIN 14)=Low

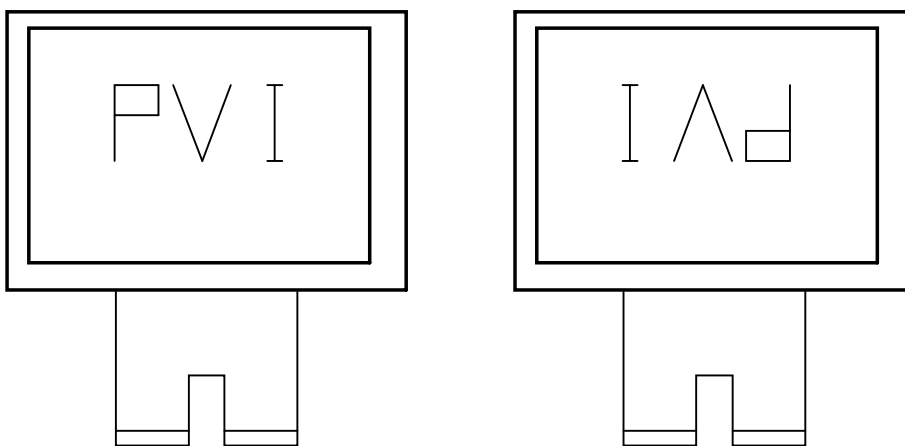

Note 5-10 : IF1,IF2 control the input data format.

IF2,IF1	Input data format
L,L (default)	Serial RGB
L,H	Parallel RGB
H,L	CCIR601
H,H	CCIR656

Note 5-11 : When POL=L, output voltage is negative polarity.

.When POL=H, output voltage is positive polarity.

Note 5-12 : Digital data input. DX0 is LSB and DX7 is MSB.

If parallel RGB input mode is used, D0X, D1X, and D2X indicate R, G and B data in turn.
If serial RGB or CCIR601/656 input mode is selected, only D07~D00 are used, and others short to V_{ss}.

Note 5-13 : Horizontal sync input in digital RGB mode. Or HREF input in CCIR601 mode.

(Short to V_{ss} if not used)

Note 5-14 : Vertical sync input in digital RGB mode. Or V123 input in CCIR601 mode.

(Short to V_{ss} if not used)

Note 5-15 : The output voltage is determined by the digital input data. If digital RGB or CCIR601/656 input mode is selected, The 8 gamma correction reference voltages can be set to externally or generate internally.

If VSET = "H", the gamma correction voltage generated externally

If VSET = "L", the default value is as below :

	V1	V2	V3	V4	V5	V6	V7	V8
Default Voltage(V)	4.29	3.73	3.33	2.94	2.62	2.22	1.51	0.48

Gamma correction characteristic curve:

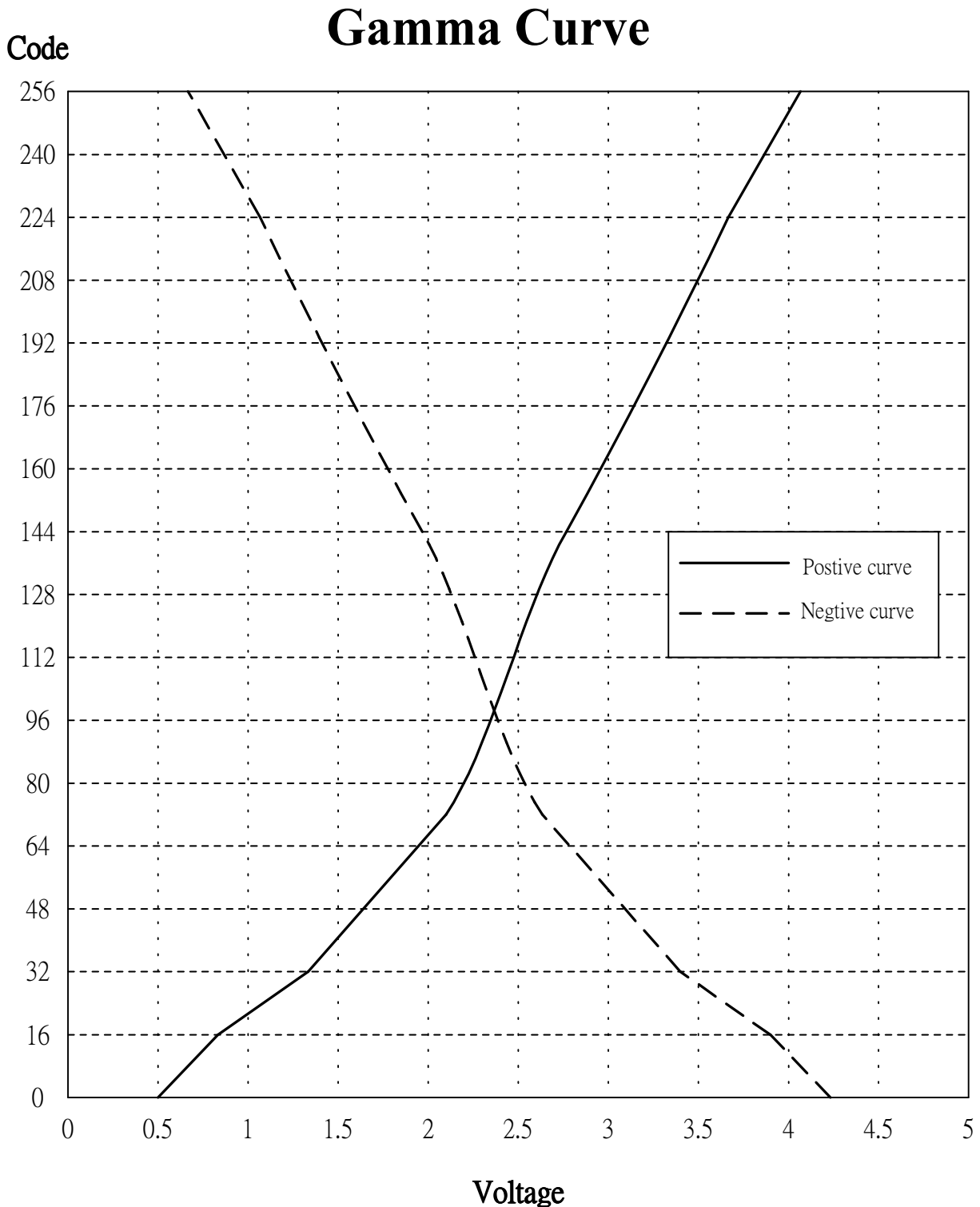

Relationship between input data and output voltage:

Positive polarity output voltage			Ω	Negative polarity output voltage			Ω
00H	VP0	V1	114	00H	VN0	V8	114
01H	VP1	$V2+(V1-V2) \times 2052 / 2166$	114	01H	VN1	$V8+(V7-V8) \times 114 / 4104$	114
02H	VP2	$V2+(V1-V2) \times 1938 / 2166$	114	02H	VN2	$V8+(V7-V8) \times 228 / 4104$	114
03H	VP3	$V2+(V1-V2) \times 1824 / 2166$	114	03H	VN3	$V8+(V7-V8) \times 342 / 4104$	114
04H	VP4	$V2+(V1-V2) \times 1710 / 2166$	114	04H	VN4	$V8+(V7-V8) \times 456 / 4104$	114
05H	VP5	$V2+(V1-V2) \times 1596 / 2166$	114	05H	VN5	$V8+(V7-V8) \times 570 / 4104$	114
06H	VP6	$V2+(V1-V2) \times 1482 / 2166$	114	06H	VN6	$V8+(V7-V8) \times 684 / 4104$	114
07H	VP7	$V2+(V1-V2) \times 1368 / 2166$	114	07H	VN7	$V8+(V7-V8) \times 798 / 4104$	114
08H	VP8	$V2+(V1-V2) \times 1254 / 2166$	114	08H	VN8	$V8+(V7-V8) \times 912 / 4104$	114
09H	VP9	$V2+(V1-V2) \times 1140 / 2166$	114	09H	VN9	$V8+(V7-V8) \times 1026 / 4104$	114
0AH	VP10	$V2+(V1-V2) \times 1026 / 2166$	114	0AH	VN10	$V8+(V7-V8) \times 1140 / 4104$	114
0BH	VP11	$V2+(V1-V2) \times 912 / 2166$	114	0BH	VN11	$V8+(V7-V8) \times 1254 / 4104$	114
0CH	VP12	$V2+(V1-V2) \times 798 / 2166$	114	0CH	VN12	$V8+(V7-V8) \times 1368 / 4104$	114
0DH	VP13	$V2+(V1-V2) \times 684 / 2166$	114	0DH	VN13	$V8+(V7-V8) \times 1482 / 4104$	114
0EH	VP14	$V2+(V1-V2) \times 570 / 2166$	114	0EH	VN14	$V8+(V7-V8) \times 1596 / 4104$	114
0FH	VP15	$V2+(V1-V2) \times 456 / 2166$	114	0FH	VN15	$V8+(V7-V8) \times 1710 / 4104$	114
10H	VP16	$V2+(V1-V2) \times 342 / 2166$	114	10H	VN16	$V8+(V7-V8) \times 1824 / 4104$	114
11H	VP17	$V2+(V1-V2) \times 228 / 2166$	114	11H	VN17	$V8+(V7-V8) \times 1938 / 4104$	114
12H	VP18	$V2+(V1-V2) \times 114 / 2166$	114	12H	VN18	$V8+(V7-V8) \times 2052 / 4104$	114
13H	VP19	V2	114	13H	VN19	$V8+(V7-V8) \times 2166 / 4104$	114
14H	VP20	$V3+(V2-V3) \times 1482 / 1596$	114	14H	VN20	$V8+(V7-V8) \times 2280 / 4104$	114
05H	VP21	$V3+(V2-V3) \times 1368 / 1596$	114	05H	VN21	$V8+(V7-V8) \times 2394 / 4104$	114
16H	VP22	$V3+(V2-V3) \times 1254 / 1596$	114	16H	VN22	$V8+(V7-V8) \times 2508 / 4104$	114
17H	VP23	$V3+(V2-V3) \times 1140 / 1596$	114	17H	VN23	$V8+(V7-V8) \times 2622 / 4104$	114
18H	VP24	$V3+(V2-V3) \times 1026 / 1596$	114	18H	VN24	$V8+(V7-V8) \times 2736 / 4104$	114
19H	VP25	$V3+(V2-V3) \times 912 / 1596$	114	19H	VN25	$V8+(V7-V8) \times 2850 / 4104$	114
1AH	VP26	$V3+(V2-V3) \times 798 / 1596$	114	1AH	VN26	$V8+(V7-V8) \times 2964 / 4104$	114
1BH	VP27	$V3+(V2-V3) \times 684 / 1596$	114	1BH	VN27	$V8+(V7-V8) \times 3078 / 4104$	114
1CH	VP28	$V3+(V2-V3) \times 570 / 1596$	114	1CH	VN28	$V8+(V7-V8) \times 3192 / 4104$	114
1DH	VP29	$V3+(V2-V3) \times 456 / 1596$	114	1DH	VN29	$V8+(V7-V8) \times 3306 / 4104$	114
1EH	VP30	$V3+(V2-V3) \times 342 / 1596$	114	1EH	VN30	$V8+(V7-V8) \times 3420 / 4104$	114
1FH	VP31	$V3+(V2-V3) \times 228 / 1596$	114	1FH	VN31	$V8+(V7-V8) \times 3534 / 4104$	114
20H	VP32	$V3+(V2-V3) \times 114 / 1596$	114	20H	VN32	$V8+(V7-V8) \times 3648 / 4104$	114
21H	VP33	V3	114	21H	VN33	$V8+(V7-V8) \times 3762 / 4104$	114
22H	VP34	$V4+(V3-V4) \times 1476 / 1590$	114	22H	VN34	$V8+(V7-V8) \times 3876 / 4104$	114
23H	VP35	$V4+(V3-V4) \times 1362 / 1590$	114	23H	VN35	$V8+(V7-V8) \times 3990 / 4104$	114
24H	VP36	$V4+(V3-V4) \times 1248 / 1590$	78	24H	VN36	V7	78
25H	VP37	$V4+(V3-V4) \times 1170 / 1590$	78	25H	VN37	$V7+(V6-V7) \times 78 / 2808$	78
26H	VP38	$V4+(V3-V4) \times 1092 / 1590$	78	26H	VN38	$V7+(V6-V7) \times 156 / 2808$	78
27H	VP39	$V4+(V3-V4) \times 1014 / 1590$	78	27H	VN39	$V7+(V6-V7) \times 234 / 2808$	78
28H	VP40	$V4+(V3-V4) \times 936 / 1590$	78	28H	VN40	$V7+(V6-V7) \times 312 / 2808$	78
29H	VP41	$V4+(V3-V4) \times 858 / 1590$	78	29H	VN41	$V7+(V6-V7) \times 390 / 2808$	78
2AH	VP42	$V4+(V3-V4) \times 780 / 1590$	78	2AH	VN42	$V7+(V6-V7) \times 468 / 2808$	78
2BH	VP43	$V4+(V3-V4) \times 702 / 1590$	78	2BH	VN43	$V7+(V6-V7) \times 546 / 2808$	78
2CH	VP44	$V4+(V3-V4) \times 624 / 1590$	78	2CH	VN44	$V7+(V6-V7) \times 624 / 2808$	78
2DH	VP45	$V4+(V3-V4) \times 546 / 1590$	78	2DH	VN45	$V7+(V6-V7) \times 702 / 2808$	78
2EH	VP46	$V4+(V3-V4) \times 468 / 1590$	78	2EH	VN46	$V7+(V6-V7) \times 780 / 2808$	78
2FH	VP47	$V4+(V3-V4) \times 390 / 1590$	78	2FH	VN47	$V7+(V6-V7) \times 858 / 2808$	78
30H	VP48	$V4+(V3-V4) \times 312 / 1590$	78	30H	VN48	$V7+(V6-V7) \times 936 / 2808$	78
31H	VP49	$V4+(V3-V4) \times 234 / 1590$	78	31H	VN49	$V7+(V6-V7) \times 1014 / 2808$	78
32H	VP50	$V4+(V3-V4) \times 156 / 1590$	78	32H	VN50	$V7+(V6-V7) \times 1092 / 2808$	78
33H	VP51	$V4+(V3-V4) \times 78 / 1590$	78	33H	VN51	$V7+(V6-V7) \times 1170 / 2808$	78
34H	VP52	V4	78	34H	VN52	$V7+(V6-V7) \times 1248 / 2808$	78
35H	VP53	$V5+(V4-V5) \times 1170 / 1248$	78	35H	VN53	$V7+(V6-V7) \times 1326 / 2808$	78
36H	VP54	$V5+(V4-V5) \times 1092 / 1248$	78	36H	VN54	$V7+(V6-V7) \times 1404 / 2808$	78
37H	VP55	$V5+(V4-V5) \times 1014 / 1248$	78	37H	VN55	$V7+(V6-V7) \times 1482 / 2808$	78
38H	VP56	$V5+(V4-V5) \times 936 / 1248$	78	38H	VN56	$V7+(V6-V7) \times 1560 / 2808$	78
39H	VP57	$V5+(V4-V5) \times 858 / 1248$	78	39H	VN57	$V7+(V6-V7) \times 1638 / 2808$	78
3AH	VP58	$V5+(V4-V5) \times 780 / 1248$	78	3AH	VN58	$V7+(V6-V7) \times 1716 / 2808$	78
3BH	VP59	$V5+(V4-V5) \times 702 / 1248$	78	3BH	VN59	$V7+(V6-V7) \times 1794 / 2808$	78
3CH	VP60	$V5+(V4-V5) \times 624 / 1248$	78	3CH	VN60	$V7+(V6-V7) \times 1872 / 2808$	78
3DH	VP61	$V5+(V4-V5) \times 546 / 1248$	78	3DH	VN61	$V7+(V6-V7) \times 1950 / 2808$	78
3EH	VP62	$V5+(V4-V5) \times 468 / 1248$	78	3EH	VN62	$V7+(V6-V7) \times 2028 / 2808$	78
3FH	VP63	$V5+(V4-V5) \times 390 / 1248$	78	3FH	VN63	$V7+(V6-V7) \times 2106 / 2808$	78

Data	Positive polarity output voltage		Ω	Data	Negative polarity output voltage		Ω
40H	VP64	$V5+(V4-V5) \times 312 / 1248$	78	40H	VN64	$V7+(V6-V7) \times 2184 / 2808$	78
41H	VP65	$V5+(V4-V5) \times 234 / 1248$	78	41H	VN65	$V7+(V6-V7) \times 2262 / 2808$	78
42H	VP66	$V5+(V4-V5) \times 156 / 1248$	78	42H	VN66	$V7+(V6-V7) \times 2340 / 2808$	78
43H	VP67	$V5+(V4-V5) \times 78 / 1248$	78	43H	VN67	$V7+(V6-V7) \times 2418 / 2808$	78
44H	VP68	V5	78	44H	VN68	$V7+(V6-V7) \times 2496 / 2808$	78
45H	VP69	$V6+(V5-V6) \times 1510 / 1588$	78	45H	VN69	$V7+(V6-V7) \times 2574 / 2808$	78
46H	VP70	$V6+(V5-V6) \times 1432 / 1588$	78	46H	VN70	$V7+(V6-V7) \times 2652 / 2808$	78
47H	VP71	$V6+(V5-V6) \times 1354 / 1588$	78	47H	VN71	$V7+(V6-V7) \times 2730 / 2808$	78
48H	VP72	$V6+(V5-V6) \times 1276 / 1588$	44	48H	VN72	V6	44
49H	VP73	$V6+(V5-V6) \times 1232 / 1588$	44	49H	VN73	$V6+(V5-V6) \times 44 / 1584$	44
4AH	VP74	$V6+(V5-V6) \times 1188 / 1588$	44	4AH	VN74	$V6+(V5-V6) \times 88 / 1584$	44
4BH	VP75	$V6+(V5-V6) \times 1144 / 1588$	44	4BH	VN75	$V6+(V5-V6) \times 132 / 1584$	44
4CH	VP76	$V6+(V5-V6) \times 1110 / 1588$	44	4CH	VN76	$V6+(V5-V6) \times 176 / 1584$	44
4DH	VP77	$V6+(V5-V6) \times 1056 / 1588$	44	4DH	VN77	$V6+(V5-V6) \times 220 / 1584$	44
4EH	VP78	$V6+(V5-V6) \times 1012 / 1588$	44	4EH	VN78	$V6+(V5-V6) \times 264 / 1584$	44
4FH	VP79	$V6+(V5-V6) \times 968 / 1588$	44	4FH	VN79	$V6+(V5-V6) \times 308 / 1584$	44
50H	VP80	$V6+(V5-V6) \times 924 / 1588$	44	50H	VN80	$V6+(V5-V6) \times 352 / 1584$	44
51H	VP81	$V6+(V5-V6) \times 880 / 1588$	44	51H	VN81	$V6+(V5-V6) \times 396 / 1584$	44
52H	VP82	$V6+(V5-V6) \times 836 / 1588$	44	52H	VN82	$V6+(V5-V6) \times 440 / 1584$	44
53H	VP83	$V6+(V5-V6) \times 792 / 1588$	44	53H	VN83	$V6+(V5-V6) \times 484 / 1584$	44
54H	VP84	$V6+(V5-V6) \times 748 / 1588$	44	54H	VN84	$V6+(V5-V6) \times 528 / 1584$	44
55H	VP85	$V6+(V5-V6) \times 704 / 1588$	44	55H	VN85	$V6+(V5-V6) \times 572 / 1584$	44
56H	VP86	$V6+(V5-V6) \times 660 / 1588$	44	56H	VN86	$V6+(V5-V6) \times 616 / 1584$	44
57H	VP87	$V6+(V5-V6) \times 616 / 1588$	44	57H	VN87	$V6+(V5-V6) \times 660 / 1584$	44
58H	VP88	$V6+(V5-V6) \times 572 / 1588$	44	58H	VN88	$V6+(V5-V6) \times 704 / 1584$	44
59H	VP89	$V6+(V5-V6) \times 528 / 1588$	44	59H	VN89	$V6+(V5-V6) \times 748 / 1584$	44
5AH	VP90	$V6+(V5-V6) \times 484 / 1588$	44	5AH	VN90	$V6+(V5-V6) \times 792 / 1584$	44
5BH	VP91	$V6+(V5-V6) \times 440 / 1588$	44	5BH	VN91	$V6+(V5-V6) \times 836 / 1584$	44
5CH	VP92	$V6+(V5-V6) \times 396 / 1588$	44	5CH	VN92	$V6+(V5-V6) \times 880 / 1584$	44
5DH	VP93	$V6+(V5-V6) \times 352 / 1588$	44	5DH	VN93	$V6+(V5-V6) \times 924 / 1584$	44
5EH	VP94	$V6+(V5-V6) \times 308 / 1588$	44	5EH	VN94	$V6+(V5-V6) \times 968 / 1584$	44
5FH	VP95	$V6+(V5-V6) \times 264 / 1588$	44	5FH	VN95	$V6+(V5-V6) \times 1012 / 1584$	44
60H	VP96	$V6+(V5-V6) \times 220 / 1588$	44	60H	VN96	$V6+(V5-V6) \times 1056 / 1584$	44
61H	VP97	$V6+(V5-V6) \times 176 / 1588$	44	61H	VN97	$V6+(V5-V6) \times 1100 / 1584$	44
62H	VP98	$V6+(V5-V6) \times 132 / 1588$	44	62H	VN98	$V6+(V5-V6) \times 1144 / 1584$	44
63H	VP99	$V6+(V5-V6) \times 88 / 1588$	44	63H	VN99	$V6+(V5-V6) \times 1188 / 1584$	44
64H	VP100	$V6+(V5-V6) \times 44 / 1588$	44	64H	VN100	$V6+(V5-V6) \times 1232 / 1584$	44
65H	VP101	V6	44	65H	VN101	$V6+(V5-V6) \times 1276 / 1584$	44
66H	VP102	$V7+(V6-V7) \times 2744 / 2788$	44	66H	VN102	$V6+(V5-V6) \times 1320 / 1584$	44
67H	VP103	$V7+(V6-V7) \times 2700 / 2788$	44	67H	VN103	$V6+(V5-V6) \times 1364 / 1584$	44
68H	VP104	$V7+(V6-V7) \times 2656 / 2788$	44	68H	VN104	$V6+(V5-V6) \times 1408 / 1584$	44
69H	VP105	$V7+(V6-V7) \times 2612 / 2788$	44	69H	VN105	$V6+(V5-V6) \times 1452 / 1584$	44
6AH	VP106	$V7+(V6-V7) \times 2568 / 2788$	44	6AH	VN106	$V6+(V5-V6) \times 1496 / 1584$	44
6BH	VP107	$V7+(V6-V7) \times 2524 / 2788$	44	6BH	VN107	$V6+(V5-V6) \times 1540 / 1584$	44
6CH	VP108	$V7+(V6-V7) \times 2480 / 2788$	32	6CH	VN108	V5	32
6DH	VP109	$V7+(V6-V7) \times 2448 / 2788$	32	6DH	VN109	$V5+(V4-V5) \times 32 / 1248$	32
6EH	VP110	$V7+(V6-V7) \times 2416 / 2788$	32	6EH	VN110	$V5+(V4-V5) \times 64 / 1248$	32
6FH	VP111	$V7+(V6-V7) \times 2384 / 2788$	32	6FH	VN111	$V5+(V4-V5) \times 96 / 1248$	32
70H	VP112	$V7+(V6-V7) \times 2352 / 2788$	32	70H	VN112	$V5+(V4-V5) \times 128 / 1248$	32
71H	VP113	$V7+(V6-V7) \times 2320 / 2788$	32	71H	VN113	$V5+(V4-V5) \times 160 / 1248$	32
72H	VP114	$V7+(V6-V7) \times 2288 / 2788$	32	72H	VN114	$V5+(V4-V5) \times 192 / 1248$	32
73H	VP115	$V7+(V6-V7) \times 2256 / 2788$	32	73H	VN115	$V5+(V4-V5) \times 224 / 1248$	32
74H	VP116	$V7+(V6-V7) \times 2224 / 2788$	32	74H	VN116	$V5+(V4-V5) \times 256 / 1248$	32
75H	VP117	$V7+(V6-V7) \times 2192 / 2788$	32	75H	VN117	$V5+(V4-V5) \times 288 / 1248$	32
76H	VP118	$V7+(V6-V7) \times 2160 / 2788$	32	76H	VN118	$V5+(V4-V5) \times 320 / 1248$	32
77H	VP119	$V7+(V6-V7) \times 2128 / 2788$	32	77H	VN119	$V5+(V4-V5) \times 352 / 1248$	32
78H	VP120	$V7+(V6-V7) \times 2096 / 2788$	32	78H	VN120	$V5+(V4-V5) \times 384 / 1248$	32
79H	VP121	$V7+(V6-V7) \times 2064 / 2788$	32	79H	VN121	$V5+(V4-V5) \times 416 / 1248$	32
7AH	VP122	$V7+(V6-V7) \times 2032 / 2788$	32	7AH	VN122	$V5+(V4-V5) \times 448 / 1248$	32
7BH	VP123	$V7+(V6-V7) \times 2000 / 2788$	32	7BH	VN123	$V5+(V4-V5) \times 480 / 1248$	32
7CH	VP124	$V7+(V6-V7) \times 1968 / 2788$	32	7CH	VN124	$V5+(V4-V5) \times 512 / 1248$	32
7DH	VP125	$V7+(V6-V7) \times 1936 / 2788$	32	7DH	VN125	$V5+(V4-V5) \times 544 / 1248$	32
7EH	VP126	$V7+(V6-V7) \times 1904 / 2788$	32	7EH	VN126	$V5+(V4-V5) \times 576 / 1248$	32
7FH	VP127	$V7+(V6-V7) \times 1872 / 2788$	32	7FH	VN127	$V5+(V4-V5) \times 608 / 1248$	32

Data	Positive polarity output voltage		Ω	Data	Negative polarity output voltage		Ω
80H	VP128	$V7+(V6-V7) \times 1840 / 2788$	32	80H	VN128	$V5+(V4-V5) \times 640 / 1248$	32
81H	VP129	$V7+(V6-V7) \times 1808 / 2788$	32	81H	VN129	$V5+(V4-V5) \times 672 / 1248$	32
82H	VP130	$V7+(V6-V7) \times 1776 / 2788$	32	82H	VN130	$V5+(V4-V5) \times 704 / 1248$	32
83H	VP131	$V7+(V6-V7) \times 1744 / 2788$	32	83H	VN131	$V5+(V4-V5) \times 736 / 1248$	32
84H	VP132	$V7+(V6-V7) \times 1712 / 2788$	32	84H	VN132	$V5+(V4-V5) \times 768 / 1248$	32
85H	VP133	$V7+(V6-V7) \times 1680 / 2788$	32	85H	VN133	$V5+(V4-V5) \times 800 / 1248$	32
86H	VP134	$V7+(V6-V7) \times 1648 / 2788$	32	86H	VN134	$V5+(V4-V5) \times 832 / 1248$	32
87H	VP135	$V7+(V6-V7) \times 1616 / 2788$	32	87H	VN135	$V5+(V4-V5) \times 864 / 1248$	32
88H	VP136	$V7+(V6-V7) \times 1584 / 2788$	32	88H	VN136	$V5+(V4-V5) \times 896 / 1248$	32
89H	VP137	$V7+(V6-V7) \times 1552 / 2788$	32	89H	VN137	$V5+(V4-V5) \times 928 / 1248$	32
8AH	VP138	$V7+(V6-V7) \times 1520 / 2788$	32	8AH	VN138	$V5+(V4-V5) \times 960 / 1248$	32
8BH	VP139	$V7+(V6-V7) \times 1488 / 2788$	32	8BH	VN139	$V5+(V4-V5) \times 992 / 1248$	32
8CH	VP140	$V7+(V6-V7) \times 1456 / 2788$	32	8CH	VN140	$V5+(V4-V5) \times 1024 / 1248$	32
8DH	VP141	$V7+(V6-V7) \times 1424 / 2788$	32	8DH	VN141	$V5+(V4-V5) \times 1056 / 1248$	32
8EH	VP142	$V7+(V6-V7) \times 1392 / 2788$	32	8EH	VN142	$V5+(V4-V5) \times 1088 / 1248$	32
8FH	VP143	$V7+(V6-V7) \times 1360 / 2788$	32	8FH	VN143	$V5+(V4-V5) \times 1120 / 1248$	32
90H	VP144	$V7+(V6-V7) \times 1328 / 2788$	32	90H	VN144	$V5+(V4-V5) \times 1152 / 1248$	32
91H	VP145	$V7+(V6-V7) \times 1296 / 2788$	32	91H	VN145	$V5+(V4-V5) \times 1184 / 1248$	32
92H	VP146	$V7+(V6-V7) \times 1264 / 2788$	32	92H	VN146	$V5+(V4-V5) \times 1216 / 1248$	32
93H	VP147	$V7+(V6-V7) \times 1232 / 2788$	44	93H	VN147	V4	44
94H	VP148	$V7+(V6-V7) \times 1188 / 2788$	44	94H	VN148	$V4+(V3-V4) \times 44 / 1584$	44
95H	VP149	$V7+(V6-V7) \times 1144 / 2788$	44	95H	VN149	$V4+(V3-V4) \times 88 / 1584$	44
96H	VP150	$V7+(V6-V7) \times 1100 / 2788$	44	96H	VN150	$V4+(V3-V4) \times 132 / 1584$	44
97H	VP151	$V7+(V6-V7) \times 1056 / 2788$	44	97H	VN151	$V4+(V3-V4) \times 176 / 1584$	44
98H	VP152	$V7+(V6-V7) \times 1012 / 2788$	44	98H	VN152	$V4+(V3-V4) \times 220 / 1584$	44
99H	VP153	$V7+(V6-V7) \times 968 / 2788$	44	99H	VN153	$V4+(V3-V4) \times 264 / 1584$	44
9AH	VP154	$V7+(V6-V7) \times 924 / 2788$	44	9AH	VN154	$V4+(V3-V4) \times 308 / 1584$	44
9BH	VP155	$V7+(V6-V7) \times 880 / 2788$	44	9BH	VN155	$V4+(V3-V4) \times 352 / 1584$	44
9CH	VP156	$V7+(V6-V7) \times 836 / 2788$	44	9CH	VN156	$V4+(V3-V4) \times 396 / 1584$	44
9DH	VP157	$V7+(V6-V7) \times 792 / 2788$	44	9DH	VN157	$V4+(V3-V4) \times 440 / 1584$	44
9EH	VP158	$V7+(V6-V7) \times 748 / 2788$	44	9EH	VN158	$V4+(V3-V4) \times 484 / 1584$	44
9FH	VP159	$V7+(V6-V7) \times 704 / 2788$	44	9FH	VN159	$V4+(V3-V4) \times 528 / 1584$	44
A0H	VP160	$V7+(V6-V7) \times 660 / 2788$	44	A0H	VN160	$V4+(V3-V4) \times 572 / 1584$	44
A1H	VP161	$V7+(V6-V7) \times 616 / 2788$	44	A1H	VN161	$V4+(V3-V4) \times 616 / 1584$	44
A2H	VP162	$V7+(V6-V7) \times 572 / 2788$	44	A2H	VN162	$V4+(V3-V4) \times 660 / 1584$	44
A3H	VP163	$V7+(V6-V7) \times 528 / 2788$	44	A3H	VN163	$V4+(V3-V4) \times 704 / 1584$	44
A4H	VP164	$V7+(V6-V7) \times 484 / 2788$	44	A4H	VN164	$V4+(V3-V4) \times 748 / 1584$	44
A5H	VP165	$V7+(V6-V7) \times 440 / 2788$	44	A5H	VN165	$V4+(V3-V4) \times 792 / 1584$	44
A6H	VP166	$V7+(V6-V7) \times 396 / 2788$	44	A6H	VN166	$V4+(V3-V4) \times 836 / 1584$	44
A7H	VP167	$V7+(V6-V7) \times 352 / 2788$	44	A7H	VN167	$V4+(V3-V4) \times 880 / 1584$	44
A8H	VP168	$V7+(V6-V7) \times 308 / 2788$	44	A8H	VN168	$V4+(V3-V4) \times 924 / 1584$	44
A9H	VP169	$V7+(V6-V7) \times 264 / 2788$	44	A9H	VN169	$V4+(V3-V4) \times 968 / 1584$	44
AAH	VP170	$V7+(V6-V7) \times 220 / 2788$	44	AAH	VN170	$V4+(V3-V4) \times 1012 / 1584$	44
ABH	VP171	$V7+(V6-V7) \times 176 / 2788$	44	ABH	VN171	$V4+(V3-V4) \times 1056 / 1584$	44
ACH	VP172	$V7+(V6-V7) \times 132 / 2788$	44	ACH	VN172	$V4+(V3-V4) \times 1100 / 1584$	44
ADH	VP173	$V7+(V6-V7) \times 88 / 2788$	44	ADH	VN173	$V4+(V3-V4) \times 1144 / 1584$	44
AEH	VP174	$V7+(V6-V7) \times 44 / 2788$	44	AEH	VN174	$V4+(V3-V4) \times 1188 / 1584$	44
AFH	VP175	V7	44	AFH	VN175	$V4+(V3-V4) \times 1232 / 1584$	44
B0H	VP176	$V8+(V7-V8) \times 4052 / 4096$	44	B0H	VN176	$V4+(V3-V4) \times 1276 / 1584$	44
B1H	VP177	$V8+(V7-V8) \times 4008 / 4096$	44	B1H	VN177	$V4+(V3-V4) \times 1320 / 1584$	44
B2H	VP178	$V8+(V7-V8) \times 3964 / 4096$	44	B2H	VN178	$V4+(V3-V4) \times 1364 / 1584$	44
B3H	VP179	$V8+(V7-V8) \times 3920 / 4096$	44	B3H	VN179	$V4+(V3-V4) \times 1408 / 1584$	44
B4H	VP180	$V8+(V7-V8) \times 3876 / 4096$	44	B4H	VN180	$V4+(V3-V4) \times 1452 / 1584$	44
B5H	VP181	$V8+(V7-V8) \times 3832 / 4096$	44	B5H	VN181	$V4+(V3-V4) \times 1496 / 1584$	44
B6H	VP182	$V8+(V7-V8) \times 3788 / 4096$	44	B6H	VN182	$V4+(V3-V4) \times 1540 / 1584$	44
B7H	VP183	$V8+(V7-V8) \times 3744 / 4096$	44	B7H	VN183	V3	44
B8H	VP184	$V8+(V7-V8) \times 3700 / 4096$	44	B8H	VN184	$V3+(V2-V3) \times 44 / 1584$	44
B9H	VP185	$V8+(V7-V8) \times 3656 / 4096$	44	B9H	VN185	$V3+(V2-V3) \times 88 / 1584$	44
BAH	VP186	$V8+(V7-V8) \times 3612 / 4096$	44	BAH	VN186	$V3+(V2-V3) \times 132 / 1584$	44
BBH	VP187	$V8+(V7-V8) \times 3568 / 4096$	44	BBH	VN187	$V3+(V2-V3) \times 176 / 1584$	44
BCH	VP188	$V8+(V7-V8) \times 3524 / 4096$	44	BCH	VN188	$V3+(V2-V3) \times 220 / 1584$	44
BDH	VP189	$V8+(V7-V8) \times 3480 / 4096$	44	BDH	VN189	$V3+(V2-V3) \times 264 / 1584$	44
BEH	VP190	$V8+(V7-V8) \times 3436 / 4096$	44	BEH	VN190	$V3+(V2-V3) \times 308 / 1584$	44
BFH	VP191	$V8+(V7-V8) \times 3392 / 4096$	44	BFH	VN191	$V3+(V2-V3) \times 352 / 1584$	44

Data	Positive polarity output voltage		Ω	Data	Negative polarity output voltage		Ω
C0H	VP192	$V8+(V7-V8) \times 3348 / 4096$	44	C0H	VN192	$V3+(V2-V3) \times 396 / 1584$	44
C1H	VP193	$V8+(V7-V8) \times 3304 / 4096$	44	C1H	VN193	$V3+(V2-V3) \times 440 / 1584$	44
C2H	VP194	$V8+(V7-V8) \times 3260 / 4096$	44	C2H	VN194	$V3+(V2-V3) \times 484 / 1584$	44
C3H	VP195	$V8+(V7-V8) \times 3216 / 4096$	44	C3H	VN195	$V3+(V2-V3) \times 528 / 1584$	44
C4H	VP196	$V8+(V7-V8) \times 3172 / 4096$	44	C4H	VN196	$V3+(V2-V3) \times 572 / 1584$	44
C5H	VP197	$V8+(V7-V8) \times 3128 / 4096$	44	C5H	VN197	$V3+(V2-V3) \times 616 / 1584$	44
C6H	VP198	$V8+(V7-V8) \times 3084 / 4096$	44	C6H	VN198	$V3+(V2-V3) \times 660 / 1584$	44
C7H	VP199	$V8+(V7-V8) \times 3040 / 4096$	44	C7H	VN199	$V3+(V2-V3) \times 704 / 1584$	44
C8H	VP200	$V8+(V7-V8) \times 2996 / 4096$	44	C8H	VN200	$V3+(V2-V3) \times 748 / 1584$	44
C9H	VP201	$V8+(V7-V8) \times 2952 / 4096$	44	C9H	VN201	$V3+(V2-V3) \times 792 / 1584$	44
CAH	VP202	$V8+(V7-V8) \times 2908 / 4096$	44	CAH	VN202	$V3+(V2-V3) \times 836 / 1584$	44
CBH	VP203	$V8+(V7-V8) \times 2864 / 4096$	44	CBH	VN203	$V3+(V2-V3) \times 880 / 1584$	44
CCH	VP204	$V8+(V7-V8) \times 2820 / 4096$	44	CCH	VN204	$V3+(V2-V3) \times 924 / 1584$	44
CDH	VP205	$V8+(V7-V8) \times 2776 / 4096$	44	CDH	VN205	$V3+(V2-V3) \times 968 / 1584$	44
CEH	VP206	$V8+(V7-V8) \times 2732 / 4096$	44	CEH	VN206	$V3+(V2-V3) \times 1012 / 1584$	44
CFH	VP207	$V8+(V7-V8) \times 2688 / 4096$	44	CFH	VN207	$V3+(V2-V3) \times 1056 / 1584$	44
D0H	VP208	$V8+(V7-V8) \times 2644 / 4096$	44	D0H	VN208	$V3+(V2-V3) \times 1100 / 1584$	44
D1H	VP209	$V8+(V7-V8) \times 2600 / 4096$	44	D1H	VN209	$V3+(V2-V3) \times 1144 / 1584$	44
D2H	VP210	$V8+(V7-V8) \times 2556 / 4096$	44	D2H	VN210	$V3+(V2-V3) \times 1188 / 1584$	44
D3H	VP211	$V8+(V7-V8) \times 2512 / 4096$	44	D3H	VN211	$V3+(V2-V3) \times 1232 / 1584$	44
D4H	VP212	$V8+(V7-V8) \times 2468 / 4096$	44	D4H	VN212	$V3+(V2-V3) \times 1276 / 1584$	44
D5H	VP213	$V8+(V7-V8) \times 2424 / 4096$	44	D5H	VN213	$V3+(V2-V3) \times 1320 / 1584$	44
D6H	VP214	$V8+(V7-V8) \times 2380 / 4096$	44	D6H	VN214	$V3+(V2-V3) \times 1364 / 1584$	44
D7H	VP215	$V8+(V7-V8) \times 2336 / 4096$	44	D7H	VN215	$V3+(V2-V3) \times 1408 / 1584$	44
D8H	VP216	$V8+(V7-V8) \times 2292 / 4096$	44	D8H	VN216	$V3+(V2-V3) \times 1452 / 1584$	44
D9H	VP217	$V8+(V7-V8) \times 2248 / 4096$	44	D9H	VN217	$V3+(V2-V3) \times 1496 / 1584$	44
DAH	VP218	$V8+(V7-V8) \times 2204 / 4096$	44	DAH	VN218	$V3+(V2-V3) \times 1540 / 1584$	44
DBH	VP219	$V8+(V7-V8) \times 2160 / 4096$	60	DBH	VN219	V2	60
DCH	VP220	$V8+(V7-V8) \times 2100 / 4096$	60	DCH	VN220	$V2+(V1-V2) \times 60 / 2160$	60
DDH	VP221	$V8+(V7-V8) \times 2040 / 4096$	60	DDH	VN221	$V2+(V1-V2) \times 120 / 2160$	60
DEH	VP222	$V8+(V7-V8) \times 1980 / 4096$	60	DEH	VN222	$V2+(V1-V2) \times 180 / 2160$	60
DFH	VP223	$V8+(V7-V8) \times 1920 / 4096$	60	DFH	VN223	$V2+(V1-V2) \times 240 / 2160$	60
E0H	VP224	$V8+(V7-V8) \times 1860 / 4096$	60	E0H	VN224	$V2+(V1-V2) \times 300 / 2160$	60
E1H	VP225	$V8+(V7-V8) \times 1800 / 4096$	60	E1H	VN225	$V2+(V1-V2) \times 360 / 2160$	60
E2H	VP226	$V8+(V7-V8) \times 1740 / 4096$	60	E2H	VN226	$V2+(V1-V2) \times 420 / 2160$	60
E3H	VP227	$V8+(V7-V8) \times 1680 / 4096$	60	E3H	VN227	$V2+(V1-V2) \times 480 / 2160$	60
E4H	VP228	$V8+(V7-V8) \times 1620 / 4096$	60	E4H	VN228	$V2+(V1-V2) \times 540 / 2160$	60
E5H	VP229	$V8+(V7-V8) \times 1560 / 4096$	60	E5H	VN229	$V2+(V1-V2) \times 600 / 2160$	60
E6H	VP230	$V8+(V7-V8) \times 1500 / 4096$	60	E6H	VN230	$V2+(V1-V2) \times 660 / 2160$	60
E7H	VP231	$V8+(V7-V8) \times 1440 / 4096$	60	E7H	VN231	$V2+(V1-V2) \times 720 / 2160$	60
E8H	VP232	$V8+(V7-V8) \times 1380 / 4096$	60	E8H	VN232	$V2+(V1-V2) \times 780 / 2160$	60
E9H	VP233	$V8+(V7-V8) \times 1320 / 4096$	60	E9H	VN233	$V2+(V1-V2) \times 840 / 2160$	60
EAH	VP234	$V8+(V7-V8) \times 1260 / 4096$	60	EAH	VN234	$V2+(V1-V2) \times 900 / 2160$	60
EBH	VP235	$V8+(V7-V8) \times 1200 / 4096$	60	EBH	VN235	$V2+(V1-V2) \times 960 / 2160$	60
ECH	VP236	$V8+(V7-V8) \times 1140 / 4096$	60	ECH	VN236	$V2+(V1-V2) \times 1020 / 2160$	60
EDH	VP237	$V8+(V7-V8) \times 1080 / 4096$	60	EDH	VN237	$V2+(V1-V2) \times 1080 / 2160$	60
EEH	VP238	$V8+(V7-V8) \times 1020 / 4096$	60	EEH	VN238	$V2+(V1-V2) \times 1140 / 2160$	60
EFH	VP239	$V8+(V7-V8) \times 960 / 4096$	60	EFH	VN239	$V2+(V1-V2) \times 1200 / 2160$	60
F0H	VP240	$V8+(V7-V8) \times 900 / 4096$	60	F0H	VN240	$V2+(V1-V2) \times 1260 / 2160$	60
F1H	VP241	$V8+(V7-V8) \times 840 / 4096$	60	F1H	VN241	$V2+(V1-V2) \times 1320 / 2160$	60
F2H	VP242	$V8+(V7-V8) \times 780 / 4096$	60	F2H	VN242	$V2+(V1-V2) \times 1380 / 2160$	60
F3H	VP243	$V8+(V7-V8) \times 720 / 4096$	60	F3H	VN243	$V2+(V1-V2) \times 1440 / 2160$	60
F4H	VP244	$V8+(V7-V8) \times 660 / 4096$	60	F4H	VN244	$V2+(V1-V2) \times 1500 / 2160$	60
F5H	VP245	$V8+(V7-V8) \times 600 / 4096$	60	F5H	VN245	$V2+(V1-V2) \times 1560 / 2160$	60
F6H	VP246	$V8+(V7-V8) \times 540 / 4096$	60	F6H	VN246	$V2+(V1-V2) \times 1620 / 2160$	60
F7H	VP247	$V8+(V7-V8) \times 480 / 4096$	60	F7H	VN247	$V2+(V1-V2) \times 1680 / 2160$	60
F8H	VP248	$V8+(V7-V8) \times 420 / 4096$	60	F8H	VN248	$V2+(V1-V2) \times 1740 / 2160$	60
F9H	VP249	$V8+(V7-V8) \times 360 / 4096$	60	F9H	VN249	$V2+(V1-V2) \times 1800 / 2160$	60
FAH	VP250	$V8+(V7-V8) \times 300 / 4096$	60	FAH	VN250	$V2+(V1-V2) \times 1860 / 2160$	60
FBH	VP251	$V8+(V7-V8) \times 240 / 4096$	60	FBH	VN251	$V2+(V1-V2) \times 1920 / 2160$	60
FCH	VP252	$V8+(V7-V8) \times 180 / 4096$	60	FCH	VN252	$V2+(V1-V2) \times 1980 / 2160$	60
FDH	VP253	$V8+(V7-V8) \times 120 / 4096$	60	FDH	VN253	$V2+(V1-V2) \times 2040 / 2160$	60
FEH	VP254	$V8+(V7-V8) \times 60 / 4096$	60	FEH	VN254	$V2+(V1-V2) \times 2100 / 2160$	60
FFH	VP255	V8	60	FFH	VN255	V1	60

Note 5-15 : Digital RGB data input format

For digital RGB input data format, both SYNC. Mode and DE mode are supported. If DEN signal is fixed low, SYNC. Mode is used. Otherwise , DE mode is used.

6. Pixel Arrangement and Input Connector Pin NO.

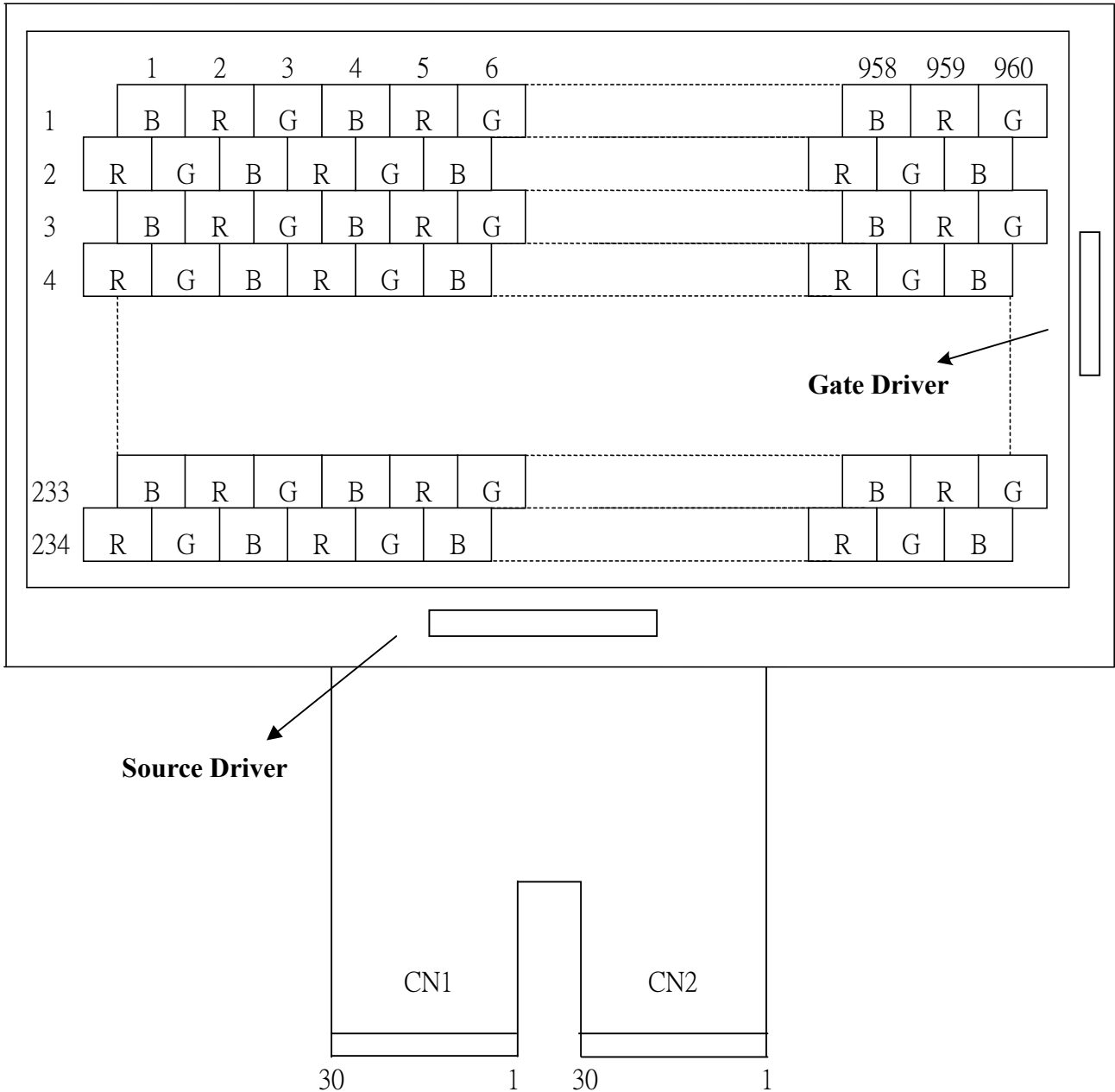

7. SPI Register Description and Timing Characteristics
7.1 Function Control Register
Register R0 :

Bit	D7	D6	D5	D4	D3	D2	D1	D0
Name	reserved	STHD1	STHD0	STHP4	STHP3	STHP2	STHP1	STHP0
Default	0	0	0	0	0	0	0	0

STHD [1:0] : adjust start pulse position by dot

STHD1	STHD0	STH position adjust by dot
1	1	-1
1	0	-2
0	0	0
0	1	+1

STHP [4:0] : adjust start pulse position by pixel

STHP4	STHP3	STHP2	STHP1	STHP0	STH position adjust by pixel
1	1	1	1	1	-1
1	1	1	1	0	-2
1	1	1	0	1	-3
1	1	1	0	0	-4
1	1	0	1	1	-5
1	1	0	1	0	-6
1	1	0	0	1	-7
1	1	0	0	0	-8
1	0	1	1	1	-9
1	0	1	1	0	-10
1	0	1	0	1	-11
1	0	1	0	0	-12
1	0	0	1	1	-13
1	0	0	1	0	-14
1	0	0	0	1	-15
1	0	0	0	0	-16
0	0	0	0	0	0
0	0	0	0	1	+1
0	0	0	1	0	+2
0	0	0	1	1	+3
0	0	1	0	0	+4
0	0	1	0	1	+5
0	0	1	1	0	+6
0	0	1	1	1	+7
0	1	0	0	0	+8
0	1	0	0	1	+9
0	1	0	1	0	+10
0	1	0	1	1	+11
0	1	1	0	0	+12
0	1	1	0	1	+13
0	1	1	1	0	+14
0	1	1	1	1	+15

Register R1 :

Bit	D7	D6	D5	D4	D3	D2	D1	D0
Name	STVP3	STVP2	STVP1	STVP0	STVNT1	STVNT0	STVPAL1	STVPAL0
Default	0	0	0	0	0	0	0	1

STVP [3:0] : adjust first line position by line

STVP3	STVP2	STVP1	STVP0	STV position adjust by line
1	1	1	1	-1
1	1	1	0	-2
1	1	0	1	-3
1	1	0	0	-4
1	0	1	1	-5
1	0	1	0	-6
1	0	0	1	-7
1	0	0	0	-8
0	0	0	0	0
0	0	0	1	+1
0	0	1	0	+2
0	0	1	1	+3
0	1	0	0	+4
0	1	0	1	+5
0	1	1	0	+6
0	1	1	1	+7

STVNT[1:0]: When NTSC mode, the relationship of first line in Even field and Odd field.

- 00: First line in Even field = First line in Odd field.
- 01: First line in Even field = First line in Odd field +1.
- 10: No use.
- 11: First line in Even field = First line in Odd field -1.

STVPAL[1:0]: When PAL mode, the relationship of first line in Even field and Odd field.

- (Just for CCIR601/656 mode)
- 00: First line in Even field = First line in Odd field.
 - 01: First line in Even field = First line in Odd field +1.
 - 10: No use.
 - 11: First line in Even field = First line in Odd field -1.

Register R2 :

Bit	D7	D6	D5	D4	D3	D2	D1	D0
Name	reserved	reserved	reserved	reserved	HS_POL	VS_POL	NPC_IN	NPC_SET
Default	0	0	0	1	0	0	1	0

HS_POL: HS polarity setting.

HS_POL = “L”, negative polarity.

HS_POL = “H”, positive polarity.

VS_POL: VS polarity setting.

VS_POL = “L”, negative polarity.

VS_POL = “H”, positive polarity.

NPC_IN: Define the NTSC/PAL mode by SPI.

NPC_IN = “L”, PAL. (Just for CCIR601/656 mode)

NPC_IN = “H”, NTSC.

NPC_SET: Set the NTSC/PAL auto detection or define by NPC_IN.

NPC_SET = “L”, auto detection.

NPC_SET = “H”, define by SPI.

Register R3 :

Bit	D7	D6	D5	D4	D3	D2	D1	D0
Name	reserved	reserved	reserved	reserved	PWD_EN	OSDCLKP	OSDHSP	OSDVSD
Default	0	0	1	0	1	0	1	1

PWD_EN: Set DAC power saving function.

PWD_EN = “L”, disable. The DAC is always power on.

PWD_EN = “H”, enable.

7-2 SPI timing characteristic

Characteristics	Symbol	Min.	Typ.	Max.	Unit	Remark
SPCK period	T_{CK}	60	-	-	ns	
SPCK high width	T_{CKH}	30	-	-	ns	
SPCK low width	T_{CKL}	30	-	-	ns	
Data setup time	T_{SU1}	12	-	-	ns	
Data hold time	T_{HD1}	12	-	-	ns	
SPENA to SPCK setup time	T_{CS}	20	-	-	ns	
SPENA to SPDA hold time	T_{CE}	20	-	-	ns	
SPENA high pulse width	T_{CD}	50	-	-	ns	
SPDA output latency	T_{CR}	-	1/2	-	T_{CK}	

● SPI "read" timing

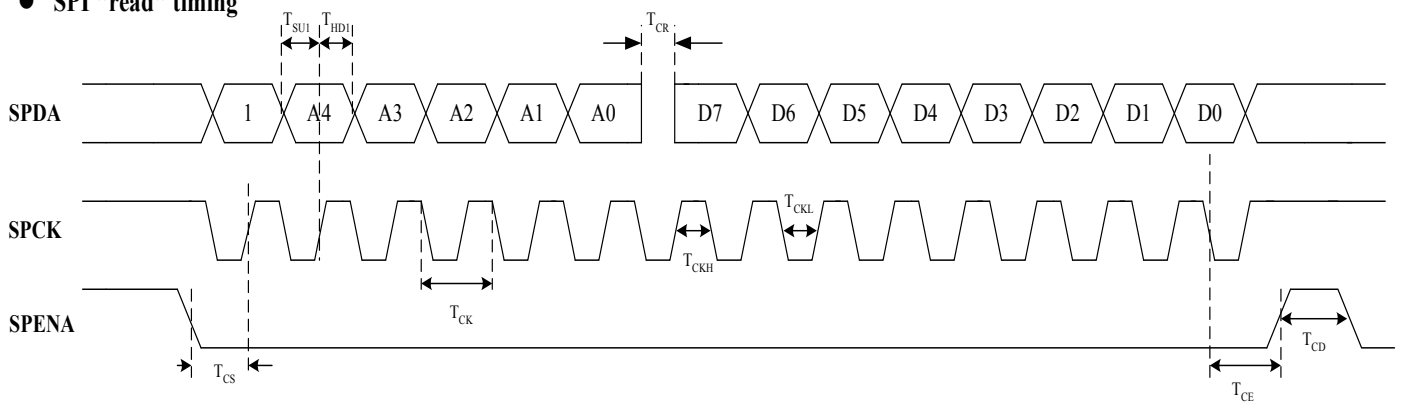

● SPI "write" timing

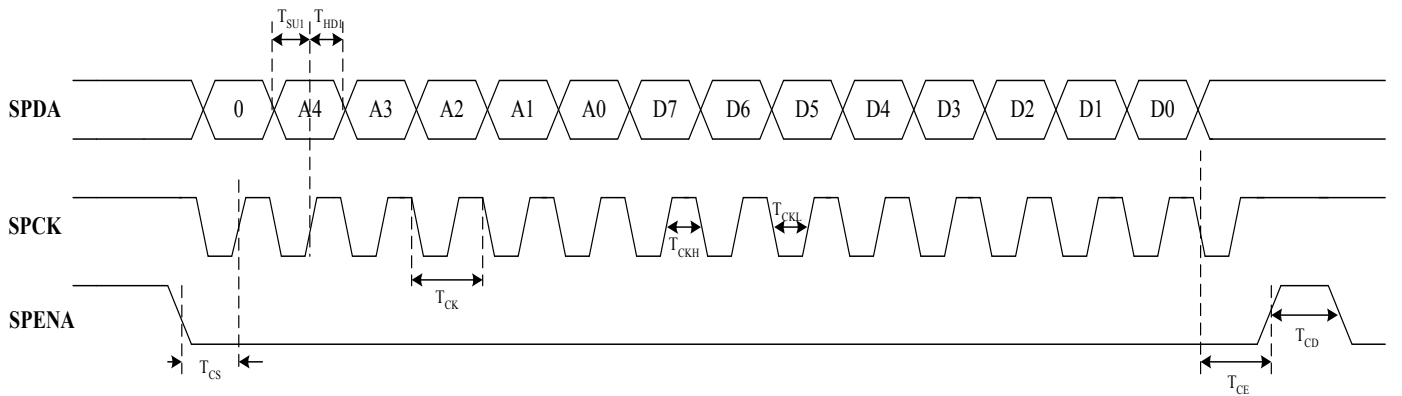

8. Absolute Maximum Ratings
 $V_{SS1}=V_{SS2}=0\text{ V}$, $T_a = 25\text{ }^\circ\text{C}$

Parameter	Symbol	MIN.	MAX.	Unit	Remark	
Supply voltage for source driver	V _{CC}	-0.3	+7.0	V		
	V _{DD2}	-0.3	+7.0	V		
Supply voltage for gate driver	V _{DD1}	-0.3	+7.0	V		
	H Level	V _{GH}	-0.3	+32.0	V	
	L Level	V _{EE}	-22.0	+0.3	V	
		V _{GH} -V _{EE}	-0.3	+45.0	V	
Input signalvoltage	V _{IN}	-0.3	V _{DD} +0.3	V		
Operation temperature		0	+60	°C		
Storage temperature		-20	+70	°C		

9. Electrical Characteristics
9-1 Operating condition
 $V_{SS1}=V_{SS2}=0\text{ V}$, $T_a = 25\text{ }^\circ\text{C}$

Parameter	Symbol	MIN.	Typ.	MAX.	Unit	Remark	
Supply voltage for source driver	Logic	V _{CC}	+3.0	+3.3	+3.6	V	
	Analog	V _{DD2}	+3.8	+5.0	+5.5	V	
Supply voltage for gate driver	Logic	V _{DD1}	+3.0	+3.3	+3.6	V	
	H level	V _{GH}	+10	+15	+30	V	
	L level	V _{EE}	-17	-15	-5	V	
Signal input voltage	H level	V _{IH}	0.7V _{CC}	-	V _{CC}	V	
	L level	V _{IL}	0	-	0.3V _{CC}	V	
Signal output voltage	H level	V _{OH}	0.8V _{CC}	-	V _{CC}	V	
	L level	V _{OL}	0	-	0.2V _{CC}	V	
V _{COM}		V _{COMAC}	-	+6.0	-	V _{P-P}	AC Component of V _{COM}
		V _{COMDC}	-	1.0	-	V	DC Component of V _{COM} Note 9-1

Note 9-1 : PVI strongly suggests that the V_{COMDC} level shall be adjustable , and the adjustable level range is 1V±1V , every module's V_{COMDC} level shall be carefully adjusted to show a best image performance.

9-2 Recommended driving condition for LED backlight

Parameter	Symbol	Min	TYP	MAX	Unit	Remark
Supply voltage of LED backlight	VLED	9.0	10.0	11.0	V	$I_L = 20\text{ mA}$
Supply current of LED backlight	ILED		20		mA	Note 9-2
Backlight Power Consumption	PLED	360	400	440	mW	Note 9-3

Note 9-2 : LED B/L applied information , please refer to the appendix at the end .

Note 9-3 : $PLED = 2 * ILED * VLED$.

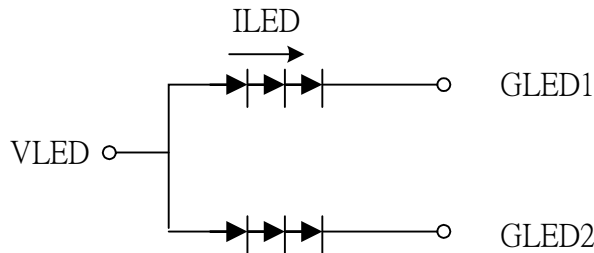

9-3 Power consumption

$V_{SS1} = V_{SS2} = 0\text{ V}$, $T_a = 25\text{ }^\circ\text{C}$

Parameter	Symbol	Conditions	TYP.	MAX.	Unit	Remark
Supply current for gate driver (Hi level)	IGH	$V_{GH} = +15\text{V}$	0.2	0.5	mA	
Supply current for gate driver (Logic)	IDD1	$V_{DD1} = +3.3\text{V}$	0.05	0.1	mA	
Supply current for gate driver (Low level)	IEE	$V_{EE} = -15\text{V}$	0.2	0.5	mA	V_{EE} center voltage
Supply current for source driver (Analog)	V_{DD2}	$V_{DD2} = +5\text{V}$	5.0	8.0	mA	
Supply current for source driver (Logic)	V_{CC}	$V_{CC} = +3.3\text{V}$	4.5	7.0	mA	
LCD panel power consumption			48	80	mW	
Backlight power consumption	PLED		400	440	mW	
Total power consumption			0.45	0.52	W	

* Above data measured on serial mode:

If on parallel mode, I_{CC} Typ.= 3.0mA, Max.=5.0mA ; panel power consumption Typ.= 41.5mW
Max.= 72.8mW.

If on CCIR601/656 mode, I_{CC} Typ.= 6.0mA, Max.=10.0mA ; panel power consumption Typ.= 51.4mW
Max.= 89.3mW.

9-4 Timing characteristics of input signals
9.4.1 Serial 8 bits RGB interface(960x234 resolution)

Characteristics	Symbol	Min.	Typ.	Max.	Unit	Remark
CLK period	T _{OSC}	-	52	-	ns	Note 9-4
Data setup time	T _{SU}	12	-	-	ns	
Data hold time	T _{HD}	12	-	-	ns	
I period	T _H	-	1224	-	T _{OSC}	
I pulse width	T _{HS}	5	90	-	T _{OSC}	
I rising time	T _{Cr}	-	-	700	ns	
I falling time	T _{Cf}	-	-	300	ns	
IVS pulse width	T _{VS}	1	3	5	T _H	
IVS rising time	T _{Vr}	-	-	700	ns	
IVS falling time	T _{Vf}	-	-	1.5	us	
IVS falling to I rising time for odd field	T _{HVO}	3	-	-	T _{OSC}	
IVS falling to I falling time for even field	T _{HVE}	3	-	-	T _{OSC}	
IVS-DEN time	T _{VSE}	-	18	-	T _H	
I-DEN time	T _{HE}	108	204	264	T _{OSC}	
DEN pulse width	T _{EP}	-	960	-	T _{OSC}	
DEN-STH time	T _{DES}	-	3	-	T _{OSC}	
IVS period		-	262	-	T _H	

Note 9-4 : When SYNC mode is used, 1st data start from 204th CLK after HIS fallings.

9.4.2 Parallel 18 bits RGB interface(960x234 resolution)

Characteristics	Symbol	Min.	Typ.	Max.	Unit	Remark
CLK period	T _{OSC}	-	156	-	ns	Note 9-5
Data setup time	T _{SU}	12	-	-	ns	
Data hold time	T _{HD}	12	-	-	ns	
I period	T _H	-	408	-	T _{OSC}	
I pulse width	T _{HS}	5	30	-	T _{OSC}	
I rising time	T _{Cr}	-	-	700	ns	
I falling time	T _{Cf}	-	-	300	ns	
IVS pulse width	T _{VS}	1	3	5	T _H	
IVS rising time	T _{Vr}	-	-	700	ns	
IVS falling time	T _{Vf}	-	-	1.5	us	
IVS falling to I rising time for odd field	T _{HVO}	3	-	-	T _{OSC}	
IVS falling to I falling time for even field	T _{HVE}	3	-	-	T _{OSC}	
IVS-DEN time	T _{VSE}	-	18	-	T _H	
I-DEN time	T _{HE}	36	68	88	T _{OSC}	
DEN pulse width	T _{EP}	-	320	-	T _{OSC}	
DEN-STH time	T _{DES}	-	3	-	T _{OSC}	
IVS period		-	262	-	T _H	

Note 9-5 : When SYNC mode is used, 1st data start from 68th CLK after HIS fallings.

9.4.3 CCIR601/656 Interface

Characteristics	Symbol	Min.	Typ.	Max.	Unit	Remark
CLK period	T _{OSC}	-	37	-	ns	
Data setup time	T _{SU}	12	-	-	ns	
Data hold time	T _{HD}	12	-	-	ns	

9.4.4 Hardware reset timing

Characteristics	Symbol	Min.	Typ.	Max.	Unit	Remark
RESETB low pulse width	T _{RSB}	200	-	-	ns	

9.5 Timing controller timing chart

9.5.1 Clock and Data waveform

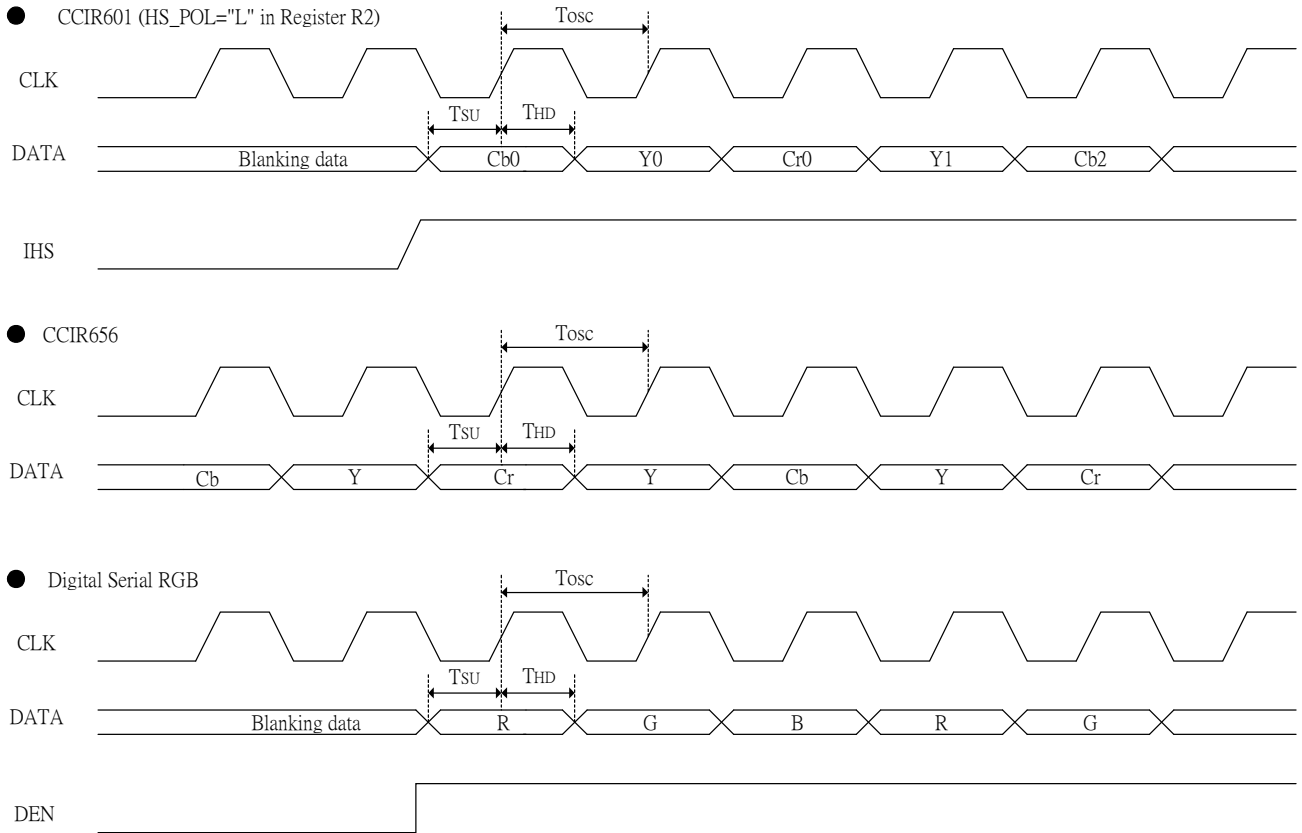

9.5.2 Digital/Analog RGB timing waveform

I and IVS timing relationship

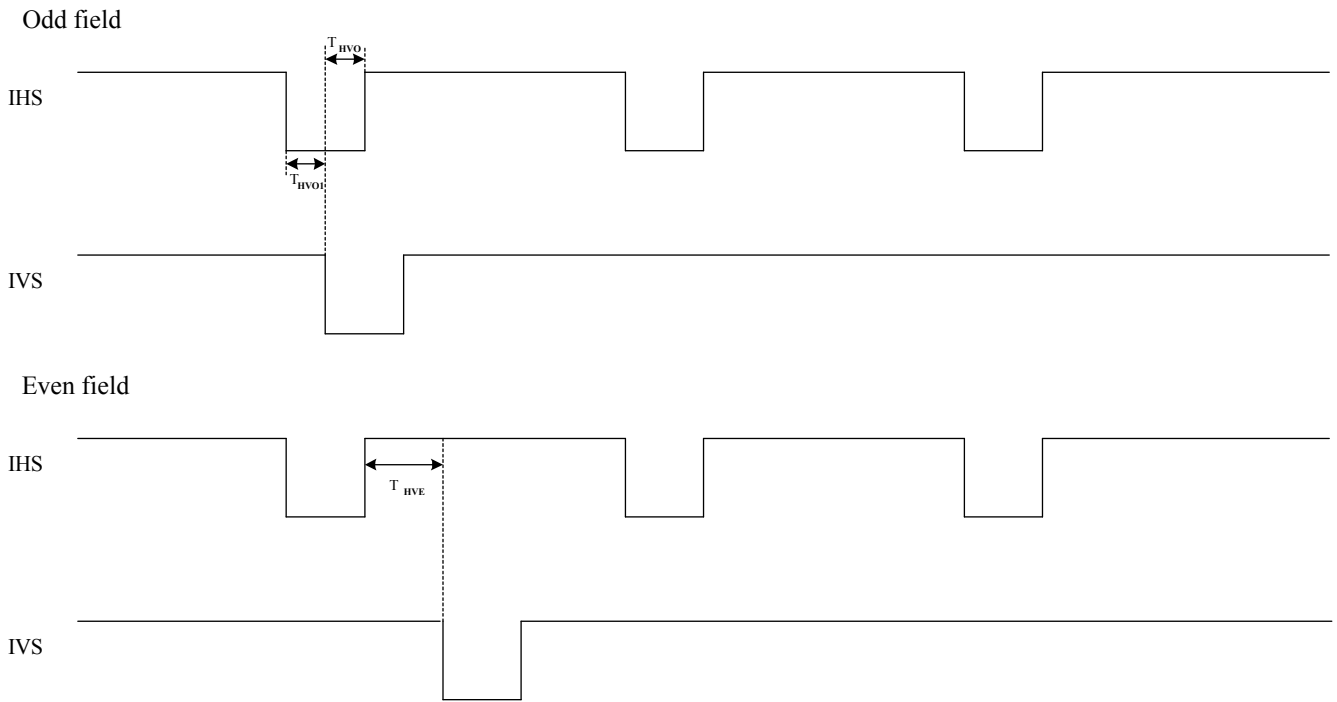

HSD and DEN timing relationship

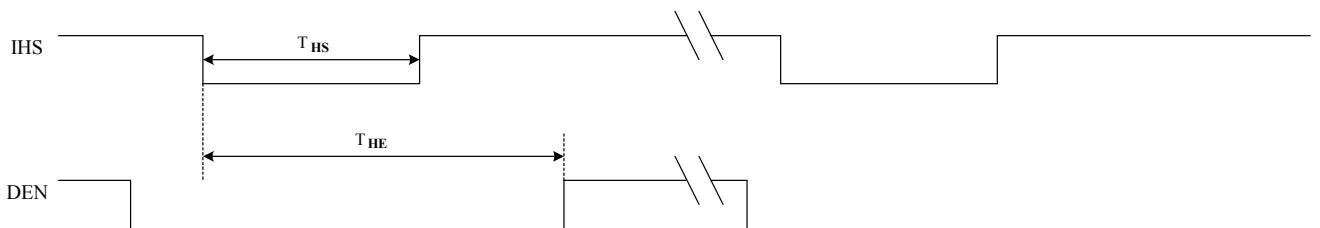

HSD, VSD and DEN timing relationship

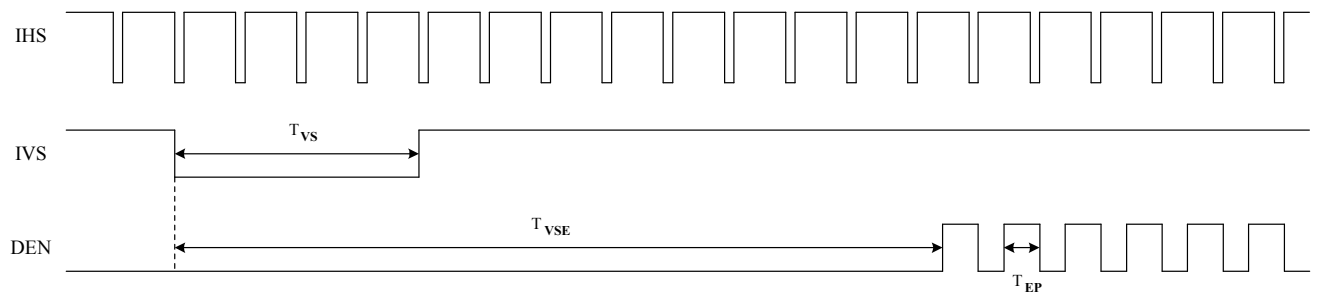

9.5.3 CCIR601 timing waveform (VS_POL="H", HS_POL="L" in Register R2)

ITU-R BT.601 NTSC Input Timing

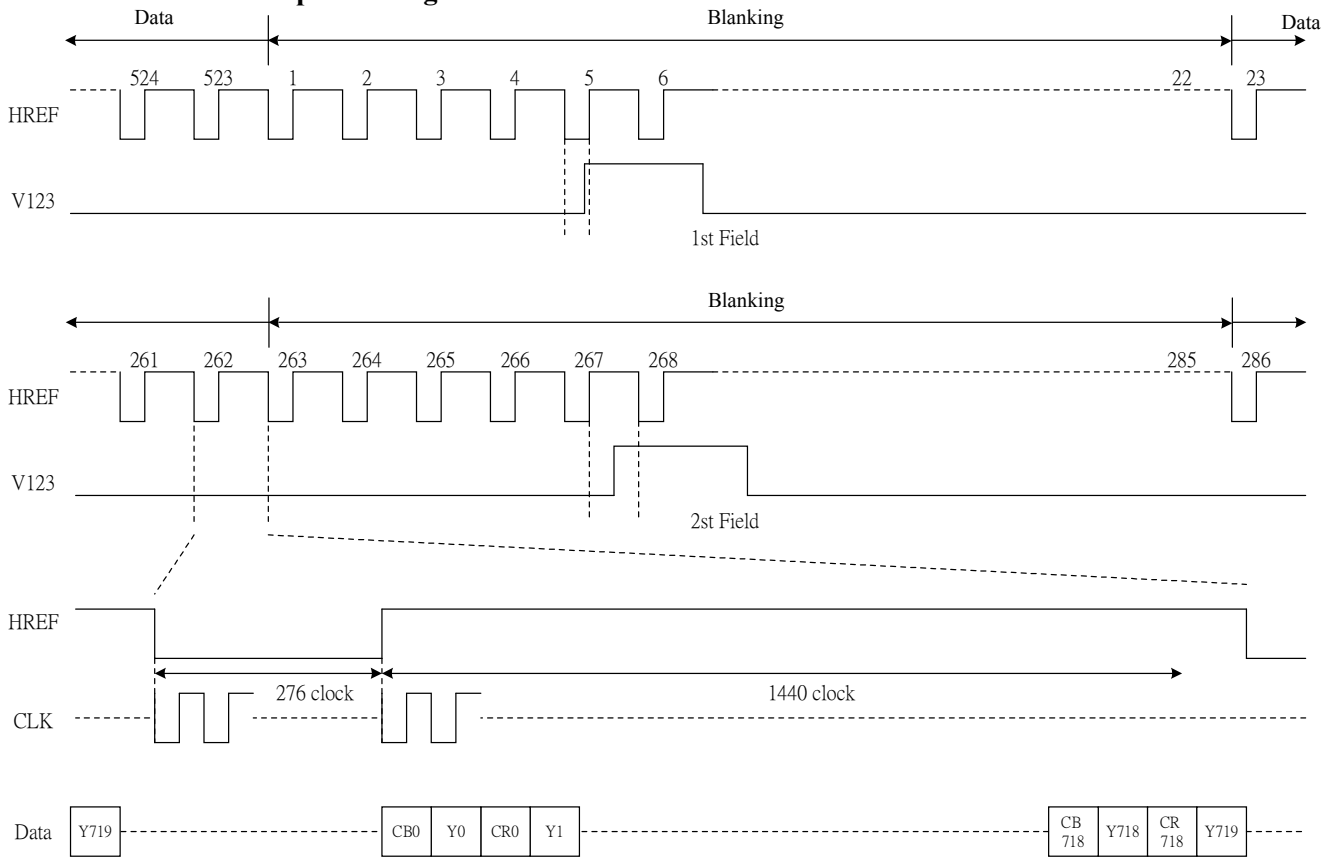

ITU-R BT.601 PAL Input Timing

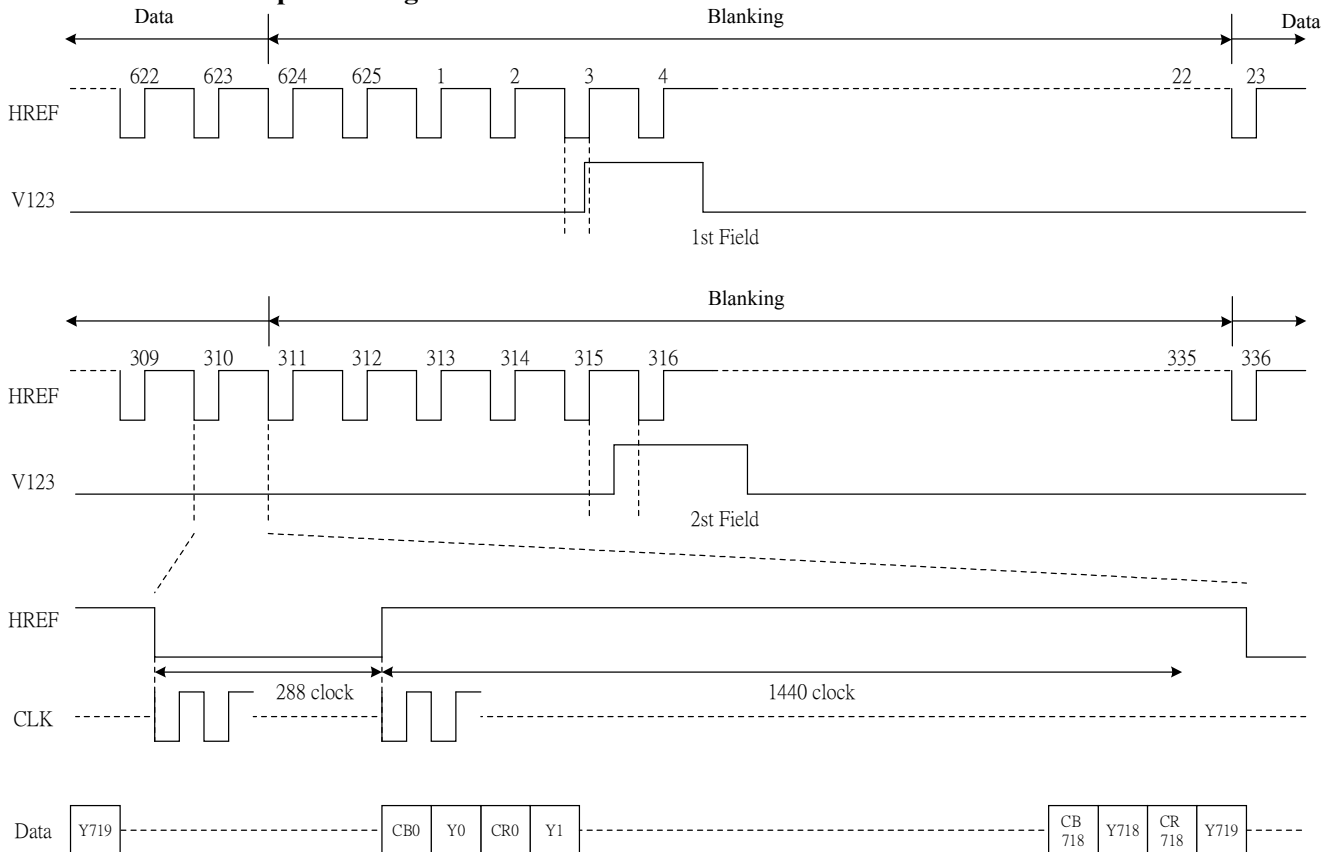

10. Power On Sequence

The Power on sequence only effect by V_{CC} , V_{SS} , V_{DD} , V_{EE} and V_{GH} , the others do not care.

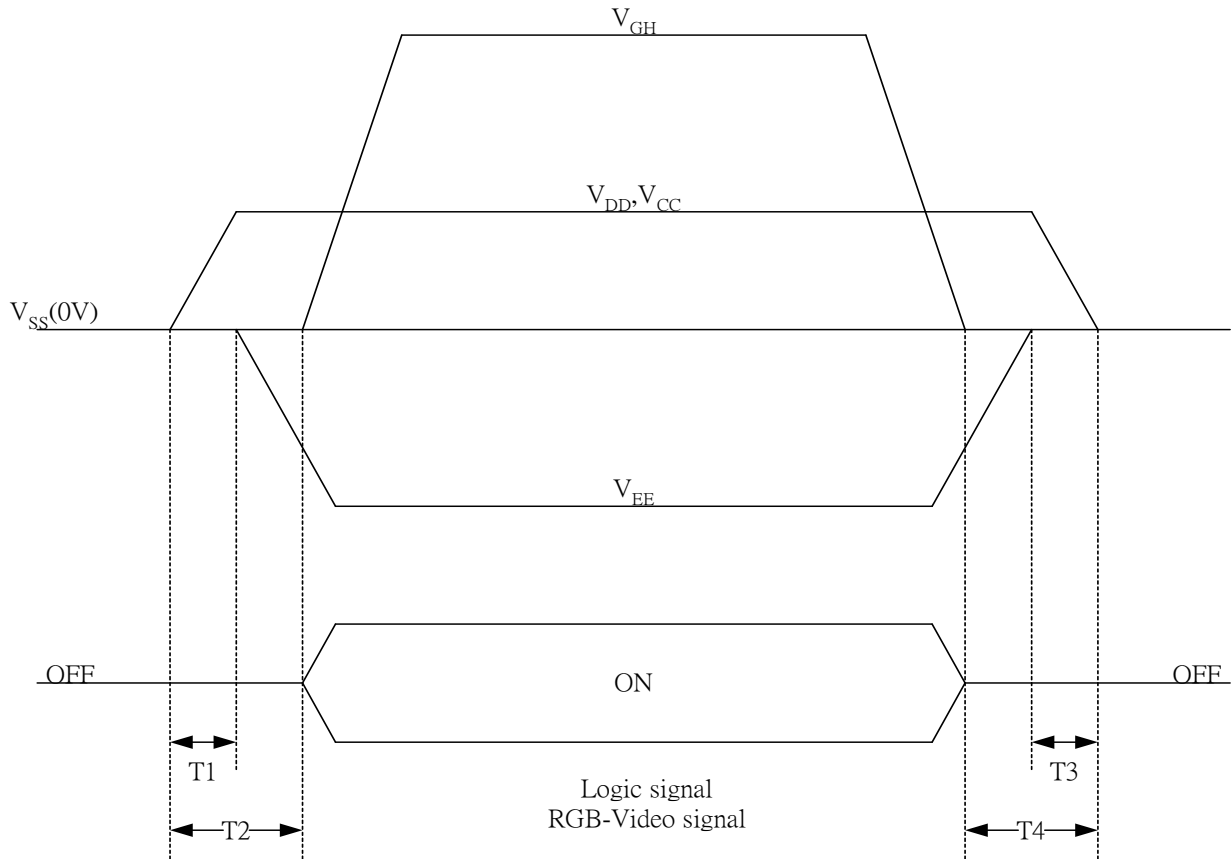

- 1) $10ms \leq T1 < T2$
- 2) $0ms < T3 \leq T4 \leq 10ms$

11. Optical Characteristics

$T_a = 25^\circ C$

Parameter		Symbol	Condition	MIN.	TYP.	MAX.	Unit	Remarks
Viewing Angle	Horizontal	$\theta 21, \theta 22$	$CR \geq 10$	45	50	---	deg	Note 11-1
	Vertical	$\theta 11$		30	35	---	deg	
		$\theta 12$		10	15	---	deg	
Contrast Ratio		CR	At optimized Viewing angle	200	400	---		Note 11-2
Response time	Rise	T_r	$\theta = 0^\circ$	---	15	30	ms	Note 11-3
	Fall	T_f		---	25	50	ms	
Uniformity		U		70	75		%	Note 11-4
Brightness				200	250		cd/m^2	Note 11-5
White		x	$\theta = 0^\circ$		0.31			Note 11-5
Chromaticity		y	$\theta = 0^\circ$		0.33			
LED Life Time		$T_a = 25^\circ C$			10000		hrs	Note 11-6

Note 11-1 : The definitions of viewing angles

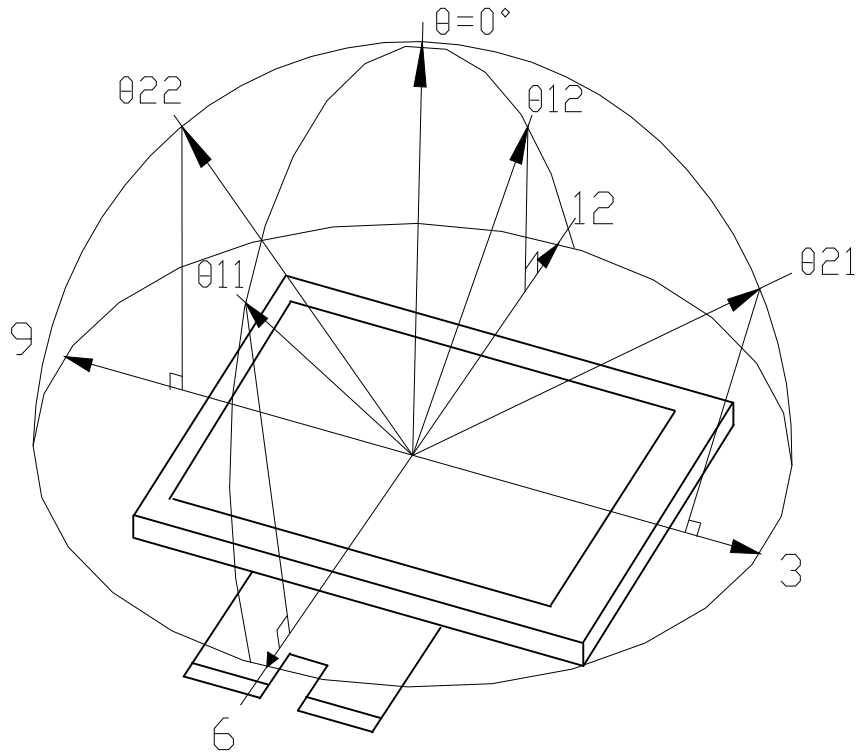

Note 11-2 : $CR = \frac{\text{Luminance when Testing point is White}}{\text{Luminance when Testing point is Black}}$

Contrast ratio is measured in optimum common electrode voltage.

Note 11-3 : The definition of response time :

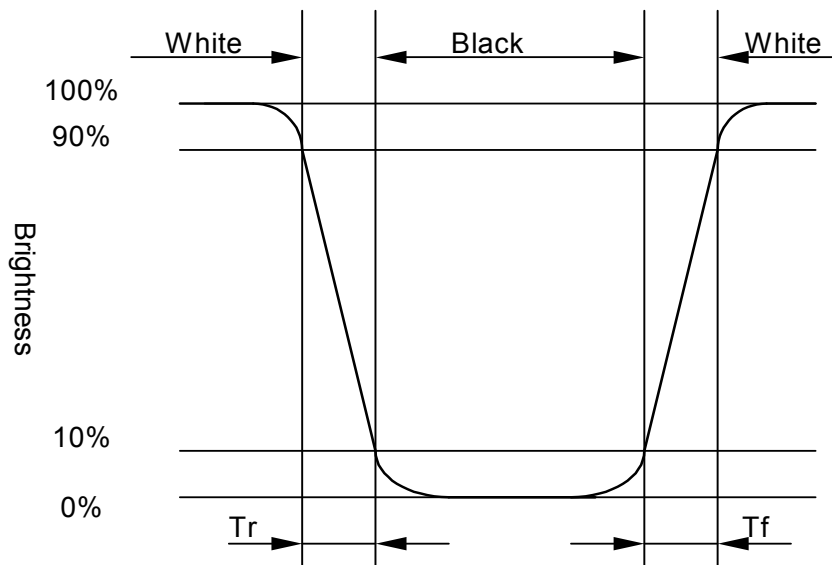

Note 11-4 : The uniformity of LCD is defined as

$$U = \frac{\text{The Minimum Brightness of the 9 testing Points}}{\text{The Maximum Brightness of the 9 testing Points}}$$

Luminance meter : BM-5A or BM-7 fast (TOPCON)

Measurement distance : 500 mm +/- 50 mm

Ambient illumination : < 1 Lux

Measuring direction : Perpendicular to the surface of module

The test pattern is white (Gray Level 63).

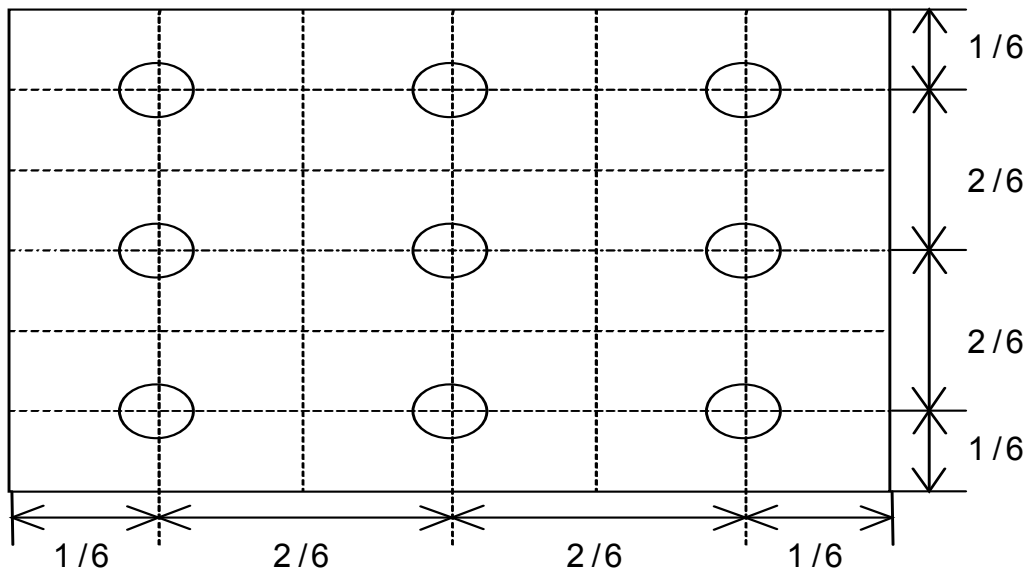

Note 11-5 : Topcon BM-7(fast) luminance meter 1.0° field of view is used in the testing (use PVI backlight after 5 minutes operating), ILED = 20mA.

Note 11-6 : Constant current 20mA for each loop , and the center brightness must more than 50% of initial brightness value .

12. Handling Cautions

12-1 Mounting of module

- a) Please power off the module when you connect the input/output connector.
- b) Please connect the ground pattern surely. If the connection is not perfect, some following problems may happen possibly.
 - 1. The noise from the backlight unit will increase.
 - 2. In some cases a part of module will heat.
- c) Polarizer which is made of soft material and susceptible to flaw must be handled carefully.
- d) Protective film (Laminator) is applied on surface to protect it against scratches and dirt. It is recommended to peel off the laminator before use and taking care of static electricity.

12-2 Precautions in mounting

- a) When metal part of the TFT-LCD module (shielding lid and rear case) is soiled, wipe it with soft dry cloth.
- b) Wipe off water drops or finger grease immediately. Long contact with water may cause discoloration or spots.
- c) TFT-LCD module uses glass which breaks or cracks easily if dropped or bumped on hard surface. Please handle with care.
- d) Since CMOS LSI is used in the module. So take care of static electricity and earth yourself when handling.

12-3 Others

- a) Do not expose the module to direct sunlight or intensive ultraviolet rays for many hours.
- b) Store the module at a room temperature place.
- c) The voltage of beginning electric discharge may over the normal voltage because of leakage current from approach conductor by to draw lump read lead line around.
- d) If LCD panel breaks, it is possibly that the liquid crystal escapes from the panel. Avoid putting it into eyes or mouth. When liquid crystal sticks on hands, clothes or feet. Wash it out immediately with soap.
- e) Observe all other precautionary requirements in handling general electronic components.

13. Reliability Test

No	Test Item	Test Condition
1	High Temperature Storage Test	Ta = +70°C, 240 hrs
2	Low Temperature Storage Test	Ta = -20°C, 240 hrs
3	Low Temperature Operation Test	Ta = 0°C, 240 hrs
4	High Temperature & High Humidity Operation Test	Ta = +60°C, 90%RH, 240 hrs
5	Thermal Cycling Test (non-operating)	-20°C ← → +70°C , 200 Cycles 30 min 30 min
6	Vibration test (non-operating)	Frequency : 10 ~ 55Hz Amplitude : 1mm , sweep time : 11 mins Test period : 6 cycles for each direction of X,Y, Z
7	Shock Test(non-operating)	100G , 6ms , 3cycles for each direction of X,Y,Z
8	Electrostatic Discharge Test (non-operating)	200pF, 0Ω Machine mode = ±200V 1 time / each terminal

Ta: ambient temperature

Note : The protective film must be removed before temperature test.

[Criteria]

Under the display quality test conditions with normal operation state, there should be no change which may affect practical display function.

14. Block Diagram

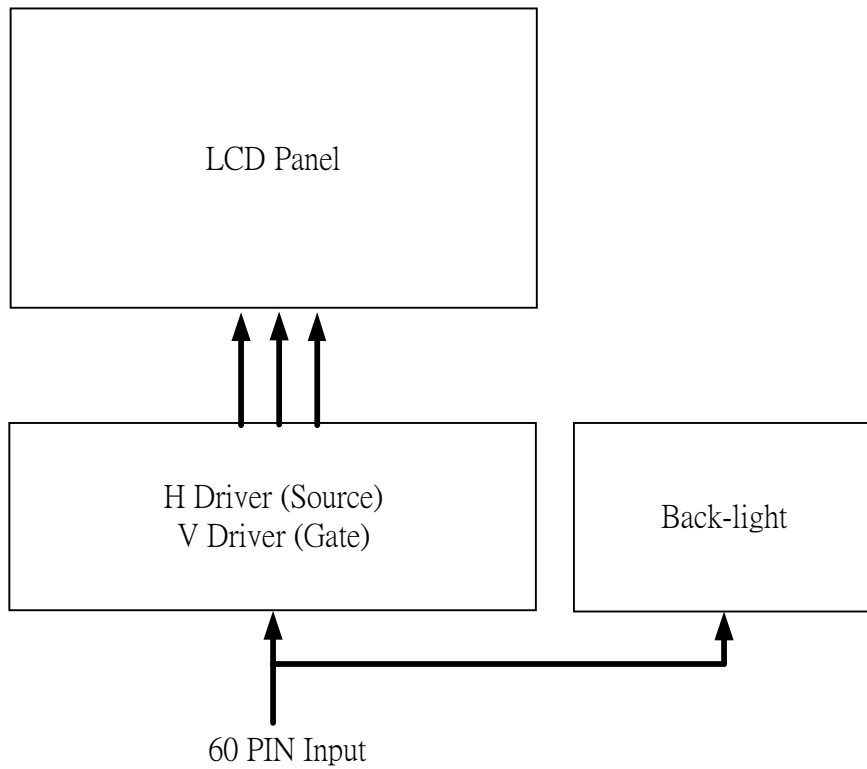

15. Packing

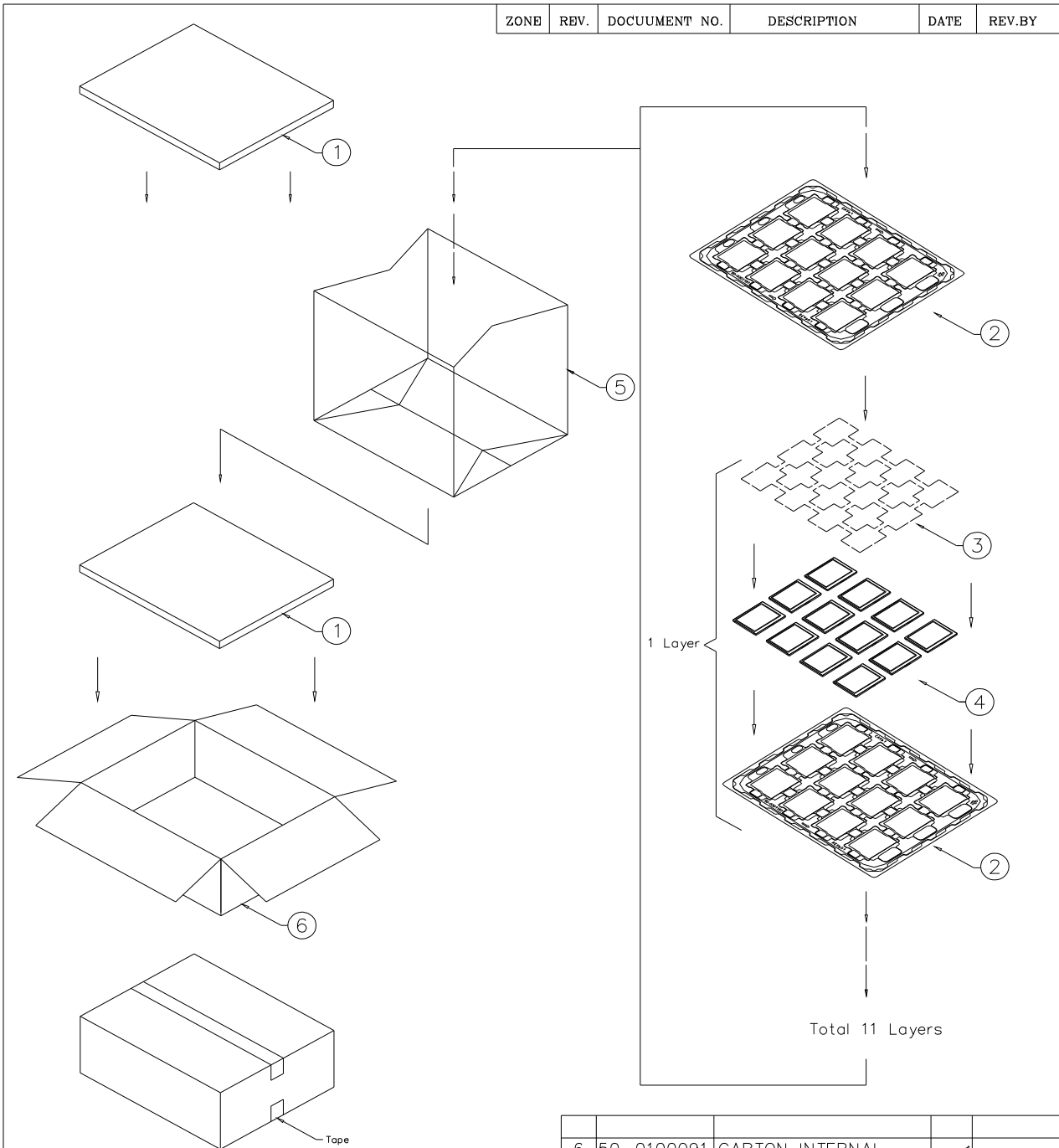

NOTE:

1. One layer include: 1 piece of cushion sheet, 12pcs panel & 1 piece of tray.
2. Q'TY: 120 pcs panel/carton.
3. Dimension: 455*375*190mm
4. Weight: 7.5 KG

6	50-0100091	CARTON INTERNAL	1	
5	50-0500041	摺口袋450*380*700mm	1	抗靜電
4		PD035OX1	120	
3	50-0200059	EPE CUSHION SHEET	10	抗靜電
2	50-0301181	TRAY	11	抗靜電
1	50-0300491	EPE FOAM	2	
ITEM	PART NO.	DESCRIPTION	QTY	REMARK

MTL.SPEC.		UNSPECIFIED TOL'S		REMARK		元太科技股份有限公司 Prime View International Co.,ltd.				
		ANGLE								
		ROUGHNESS				SCALE	UNIT	SHEET	DWG.TITLE	
APPROVE			1:1	mm	1 OF 2	PD035OX1 PACKING Dim				
CHECK			MTL.NO.			DWG.NO.		REV.	A4 SIZE	
DESIGN	Dennis	'05.06.08						01		

Revision History

Rev.	Issued Date	Revised Contents
0.1	Jan .03 , 2005	Preliminary
0.2	Feb .02 , 2005	Modify: Page07: Note5-2 V _{GH} Typ.= +15V. Page16: Register R2 – bit D5, D4 change to reserved, Register R3 – bit D6,D5,D4 change to reserved. Page18: Absolute Max. ratings – storage and operation temperature. Delete: Page21: 9.4.4 Output signal character for Digital/Analog RGB mode.
0.3	Apr. 15, 2005	Modify: Page04: Mechanical Drawing of TFT-LCD Module (FPC Outline Drawing) Add:Appendix (LED B/L driving reference circuit)
0.4	May.17, 2005	Modify: Page05: POL I/O condition to output. Page25: Uniformity Typ. from 80% to 75%.
1.0	Jun. 07, 2005	Modify: Page31: Packing

Appendix

CON 2

