

**27MHz XO IC with Audio Clock (for Set Top Boxes & MPEG Video)**

**FEATURES**

- 27MHz reference output (from 27MHz crystal input or clock input).
- Selectable Audio Clocks supporting:
  - $F_s$  of 32kHz, 44.1kHz, 48kHz, 64kHz and 96kHz
  - 8.192MHz, 11.2896MHz, 12.288MHz, and 24.576MHz audio frequencies
- On-the-fly switching of the audio frequency.
- 3.3V Operating Voltage.
- Available in 8-Pin SOIC.

**DESCRIPTION**

The PLL601-27 is a low cost integrated XO IC designed to work with a fundamental 27MHz crystal or a clock input. In addition to a 27MHz clock reference, it provides the most common audio clocks (8.192, 11.2896, 12.288, and 24.576MHz) required by sampling rates of 32kHz, 44.1kHz, 48kHz, 64kHz and 96kHz, making the chip ideal for STB and MPEG Video applications.

**PACKAGE PIN CONFIGURATION**

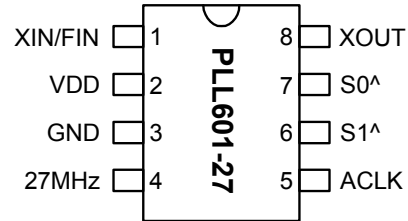

**Note:** <sup>^</sup>: Internal pull-up resistor. The internal pull-up resistor results in a default high value when no pull-down resistor is connected to this pin.

**AUDIO CLOCK SELECTION**

S1	S0	ACLK (MHz)
0	0	8.192
0	1	11.2896
1	0	12.288
1	1	24.576

**BLOCK DIAGRAM**

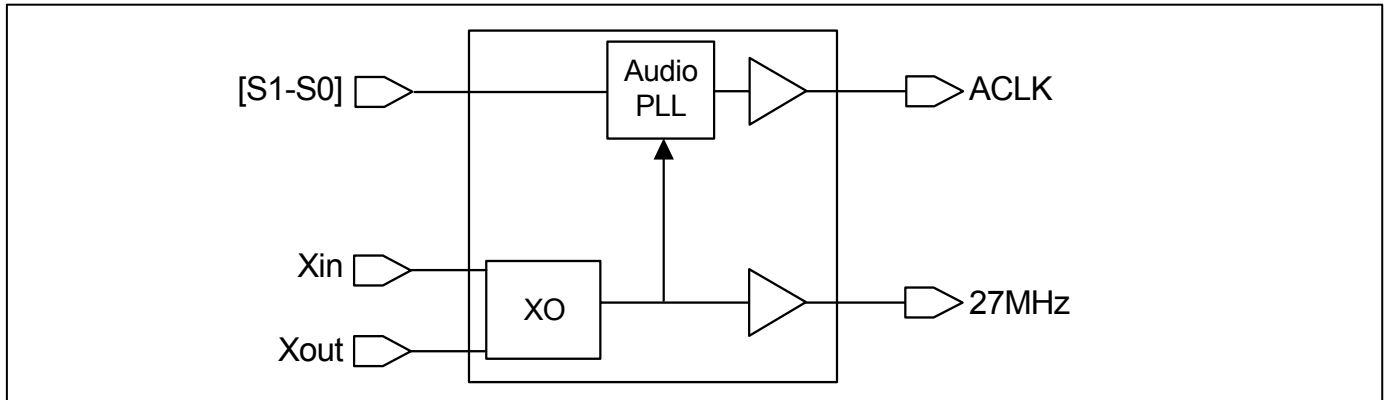

## 27MHz XO IC with Audio Clock (for Set Top Boxes & MPEG Video)

### PIN DESCRIPTIONS

Name	Pin #	Type	Description
XIN	1	I	Crystal input to be connected to fundamental parallel mode crystal. ( $C_L=15$ pF) or clock input.
VDD	2	P	Power supply.
GND	3	P	Ground.
27MHz	4	O	27MHz reference output.
ACLK	5	O	Audio clock output (see selection table on page 1).
S1	6	I	Digital control input to select audio frequency. 60k $\Omega$ internal pull-up.
S0	7	I	Digital control input to select audio frequency. 60k $\Omega$ internal pull-up.
XOUT	8	I	Crystal output.

Notes: I – input pin; P – power supply/ground pin.

### ELECTRICAL SPECIFICATIONS

#### 1. Absolute Maximum Ratings

PARAMETERS	SYMBOL	MIN.	MAX.	UNITS
Supply Voltage	$V_{DD}$		4.6	V
Input Voltage, dc	$V_I$	-0.5	$V_{DD}+0.5$	V
Output Voltage, dc	$V_O$	-0.5	$V_{DD}+0.5$	V
Storage Temperature	$T_S$	-65	150	$^{\circ}C$
Ambient Operating Temperature*	$T_A$	-40	85	$^{\circ}C$
Junction Temperature	$T_J$		125	$^{\circ}C$
Lead Temperature (soldering, 10s)			260	$^{\circ}C$
ESD Protection, Human Body Model			2	kV

Exposure of the device under conditions beyond the limits specified by Maximum Ratings for extended periods may cause permanent damage to the device and affect product reliability. These conditions represent a stress rating only, and functional operations of the device at these or any other conditions above the operational limits noted in this specification is not implied.

\* Note: Operating Temperature is guaranteed by design for all parts (COMMERCIAL and INDUSTRIAL), but tested for COMMERCIAL grade only.

#### 2. Crystal Specifications

PARAMETERS	SYMBOL	CONDITIONS	MIN.	TYP.	MAX.	UNITS
Crystal Resonator Frequency	$F_{XIN}$	Parallel Fundamental Mode		27		MHz
Crystal Loading Rating	$C_L$ (xtal)			15		pF
Recommended ESR	$R_E$	AT cut			30	$\Omega$

**27MHz XO IC with Audio Clock (for Set Top Boxes & MPEG Video)**
**3. General Electrical Specifications**

PARAMETERS	SYMBOL	CONDITIONS	MIN.	TYP.	MAX.	UNITS
Supply Current, Dynamic (with Loaded Outputs)	I <sub>DD</sub>	15pF Load		20	30	mA
Operating Voltage	V <sub>DD</sub>		2.97	3.30	3.63	V

**4. AC Electrical Specifications**

PARAMETERS	SYMBOL	CONDITIONS	MIN.	TYP.	MAX.	UNITS
Input Crystal Frequency				27		MHz
Output Clock Rise Time		0.8V ~ 2.0V with 10 pF load			1.5	ns
		0.3V ~ 3.0V with 15 pF load		2.4	5	
Output Clock Fall Time		2.0V ~ 0.8V with 10 pF load			1.5	
		3.0V ~ 0.3V with 15pF load		2.4	5	
Output Clock Duty Cycle		Measured @ 1.4V	45	50	55	%
Short Circuit Current				±50		mA

**5. Jitter Specifications**

PARAMETERS	CONDITIONS	FREQUENCY	MIN.	TYP.	MAX.	UNITS
Cycle to Cycle Jitter	T <sub>cyc-cyc</sub>	27MHz		100		ps
Cycle to Cycle Jitter	T <sub>cyc-cyc</sub>	Audio Clock		150		ps

**27MHz XO IC with Audio Clock (for Set Top Boxes & MPEG Video)**

**PACKAGE INFORMATION**

8 PIN SOIC (in mm)		
Symbol	Min.	Max.
A	1.47	1.73
A1	0.10	0.25
B	0.33	0.51
C	0.19	0.25
D	4.80	4.95
E	3.80	4.00
H	5.80	6.20
L	0.38	1.27
e	1.27 BSC	

**ORDERING INFORMATION**

**For part ordering, please contact our Sales Department:**

47745 Fremont Blvd., Fremont, CA 94538, USA

Tel: (510) 492-0990 Fax: (510) 492-0991

**PART NUMBER**

The order number for this device is a combination of the following:

Device number, Package type and Operating temperature range

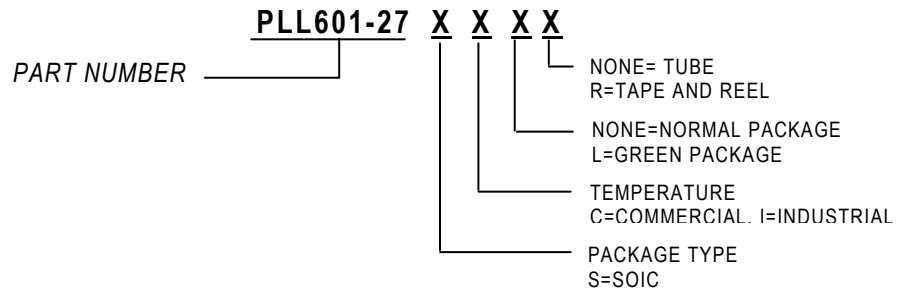

Order Number	Marking	Package Option
PLL601-27SC	P601-27SC	SOIC - Tube
PLL601-27SC-R	P601-27SC	SOIC - Tape and Reel
PLL601-27SCL	P601-27SCL	SOIC - Tube
PLL601-27SCL-R	P601-27SCL	SOIC - Tape and Reel

PhaseLink Corporation, reserves the right to make changes in its products or specifications, or both at any time without notice. The information furnished by Phaselink is believed to be accurate and reliable. However, PhaseLink makes no guarantee or warranty concerning the accuracy of said information and shall not be responsible for any loss or damage of whatever nature resulting from the use of, or reliance upon this product.

**LIFE SUPPORT POLICY:** PhaseLink's products are not authorized for use as critical components in life support devices or systems without the express written approval of the President of PhaseLink Corporation.