

## 2ch LOW DROPOUT VOLTAGE REGULATOR

### ■ GENERAL DESCRIPTION

The NJM2890 is a dual low dropout voltage regulator. Advanced Bipolar technology achieves low noise, high ripple rejection and low quiescent current.

### ■ PACKAGE OUTLINE



NJM2890R

### ■ FEATURES

- High Ripple Rejection      70dB typ. (f=1kHz,Vo=3V Version)
- Output Noise Voltage      Vno=30μVrms typ.(Cp=0.01μF)
- Output capacitor with 1.0uF ceramic capacitor (Vo≥2.7V)
- Output Current              Io(max.)=150mA × 2ch
- High Precision Output      Vo±1.0%
- Low Dropout Voltage        0.10V typ. (Io=60mA)
- Operating Voltage Range +2.5V~+14V (Vo≤2.0V version)
- ON/OFF Control            (Active High)
- Internal Short Circuit Current Limit
- Internal Thermal Overload Protection
- Bipolar Technology
- Package Outline            VSP10

### ■ PIN CONFIGURATION

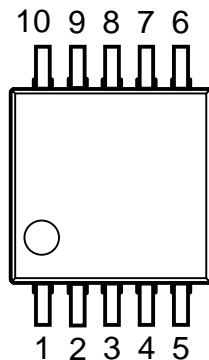

#### PIN FUNCTION

- |                     |                      |
|---------------------|----------------------|
| 1. CONTROL1         | 6. NOISE BYPASS2     |
| 2. V <sub>IN1</sub> | 7. V <sub>OUT2</sub> |
| 3. GND              | 8. GND               |
| 4. V <sub>IN2</sub> | 9. V <sub>OUT1</sub> |
| 5. CONTROL2         | 10. NOISE BYPASS1    |

NJM2890R

### ■ EQUIVALENT CIRCUIT

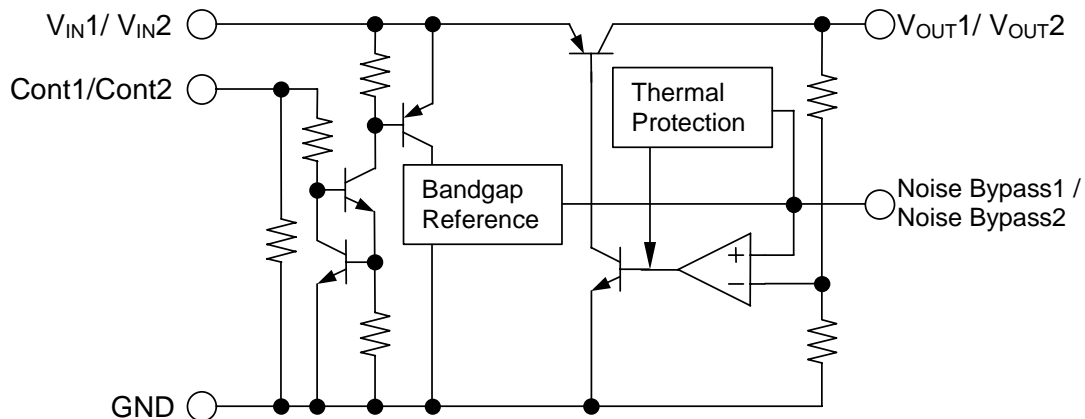

## ■ ABSOLUTE MAXIMUM RATINGS (Ta=25°C)

PARAMETER	SYMBOL	RATINGS	UNIT
Input Voltage	V <sub>IN</sub>	+14	V
Control Voltage	V <sub>CONT</sub>	+14(*1)	V
Power Dissipation	P <sub>D</sub>	320	mW
Operating Temperature	T <sub>opr</sub>	-40 ~ +85	°C
Storage Temperature	T <sub>stg</sub>	-40 ~ +125	°C

(\*1) When input voltage is less than +14V, the absolute maximum control voltage is equal to the input voltage.

## ■ OPERATING RANGE

V<sub>IN</sub>= V<sub>IN</sub>=+2.5V ~ +14.0V (In case of Vo<2.1V version)

## ■ ELECTRICAL CHARACTERISTICS

(Vo>2.0V version :

1CH/2CH : V<sub>IN</sub>=Vo+1V, C<sub>IN</sub>=0.1μF, Co=1.0uF: Vo≥2.7V (Co=2.2uF: Vo≤2.6V), Cp=0.01μF, Ta=25°C)

PARAMETER	SYMBOL	TEST CONDITION	MIN.	TYP.	MAX.	UNIT
Output Voltage	Vo	I <sub>o</sub> =30mA	-1.0%	-	+1.0%	V
Quiescent Current	I <sub>Q</sub>	I <sub>o</sub> =0mA, expect I <sub>cont</sub>	-	120	180	μA
Quiescent Current at Control OFF	I <sub>Q(OFF)</sub>	V <sub>CONT</sub> =0V	-	-	100	nA
Output Current	I <sub>o</sub>	Vo-0.3V	150	200	-	mA
Line Regulation	ΔVo/ΔV <sub>IN</sub>	V <sub>IN</sub> =Vo+1V ~ Vo+6V, I <sub>o</sub> =30mA	-	-	0.10	%/V
Load Regulation	ΔVo/ΔI <sub>o</sub>	I <sub>o</sub> =0 ~ 100mA	-	-	0.03	%/mA
Dropout Voltage	ΔV <sub>L-O</sub>	I <sub>o</sub> =60mA	-	0.10	0.18	V
Ripple Rejection	RR	e <sub>in</sub> =200mVrms, f=1kHz, I <sub>o</sub> =10mA, Vo=3V Version	-	70	-	dB
Average Temperature Coefficient of Output Voltage	ΔVo/ΔTa	Ta=0-85°C, I <sub>o</sub> =10mA	-	±50	-	ppm/°C
Output Noise Voltage	V <sub>NO</sub>	f=10Hz-80kHz, I <sub>o</sub> =10mA, Vo=3V Version	-	30	-	μVrms
Control Voltage for ON-state	V <sub>CONT(ON)</sub>		1.6	-	-	V
Control Voltage for OFF-state	V <sub>CONT(OFF)</sub>		-	-	0.6	V

(Vo≤2.0V version :

1CH/2CH : V<sub>IN</sub>=Vo+1V, C<sub>IN</sub>=0.1μF, Co=2.2uF, Cp=0.01μF, Ta=25°C)

PARAMETER	SYMBOL	TEST CONDITION	MIN.	TYP.	MAX.	UNIT
Output Voltage	Vo	I <sub>o</sub> =30mA	-1.0%	-	+1.0%	V
Quiescent Current	I <sub>Q</sub>	I <sub>o</sub> =0mA, expect I <sub>cont</sub>	-	120	180	μA
Quiescent Current at Control OFF	I <sub>Q(OFF)</sub>	V <sub>CONT</sub> =0V	-	-	100	nA
Output Current	I <sub>o</sub>	Vo-0.3V	150	200	-	mA
Line Regulation	ΔVo/ΔV <sub>IN</sub>	V <sub>IN</sub> =Vo+1V ~ Vo+6V, I <sub>o</sub> =30mA	-	-	0.10	%/V
Load Regulation	ΔVo/ΔI <sub>o</sub>	I <sub>o</sub> =0 ~ 100mA	-	-	0.03	%/mA
Ripple Rejection	RR	e <sub>in</sub> =200mVrms, f=1kHz, I <sub>o</sub> =10mA, Vo=1.8V Version	-	75	-	dB
Average Temperature Coefficient of Output Voltage	ΔVo/ΔTa	Ta=0-85°C, I <sub>o</sub> =10mA	-	±50	-	ppm/°C
Output Noise Voltage	V <sub>NO</sub>	f=10Hz-80kHz, I <sub>o</sub> =10mA, Vo=1.8V Version	-	22	-	μVrms
Control Voltage for ON-state	V <sub>CONT(ON)</sub>		1.6	-	-	V
Control Voltage for OFF-state	V <sub>CONT(OFF)</sub>		-	-	0.6	V

The above specification is a common specification for all output voltages.

Therefore, it may be different from the individual specification for a specific output voltage.

## OUTPUT VOLTAGE RANK LIST

Device Name	Vout	
	CH1	CH2
NJM2890R2121	2.1V	2.1V
NJM2890R2727	2.7V	2.7V
NJM2890R2818	2.8V	1.8V
NJM2890R2828	2.8V	2.8V
NJM2890R0318	3.0V	1.8V
NJM2890R0303	3.0V	3.0V
NJM2890R3325	3.3V	2.5V
NJM2890R3333	3.3V	3.3V
NJM2890R0403	4.0V	3.0V
NJM2890R0521	5.0V	2.1V

## TEST CIRCUIT

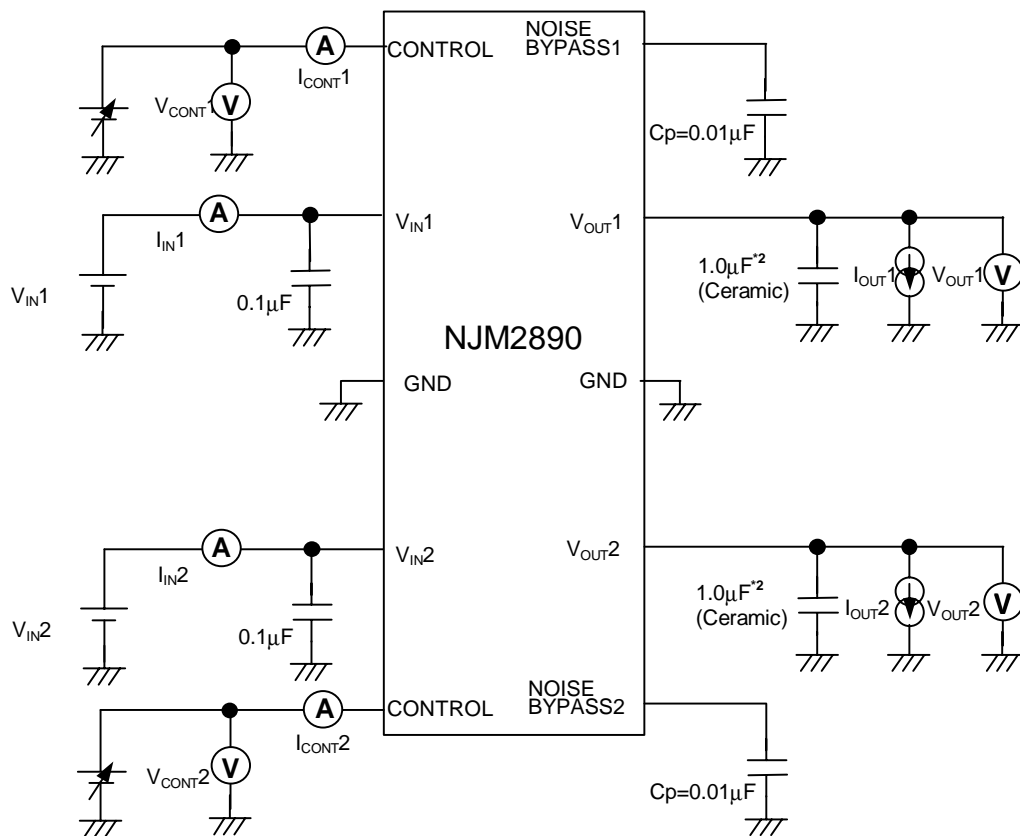

\*2  $V_{o} \leq 2.6V$  version:  $C_o = 2.2\mu F$  (ceramic)

■ TYPICAL APPLICATION

① In the case where ON/OFF Control is not required:

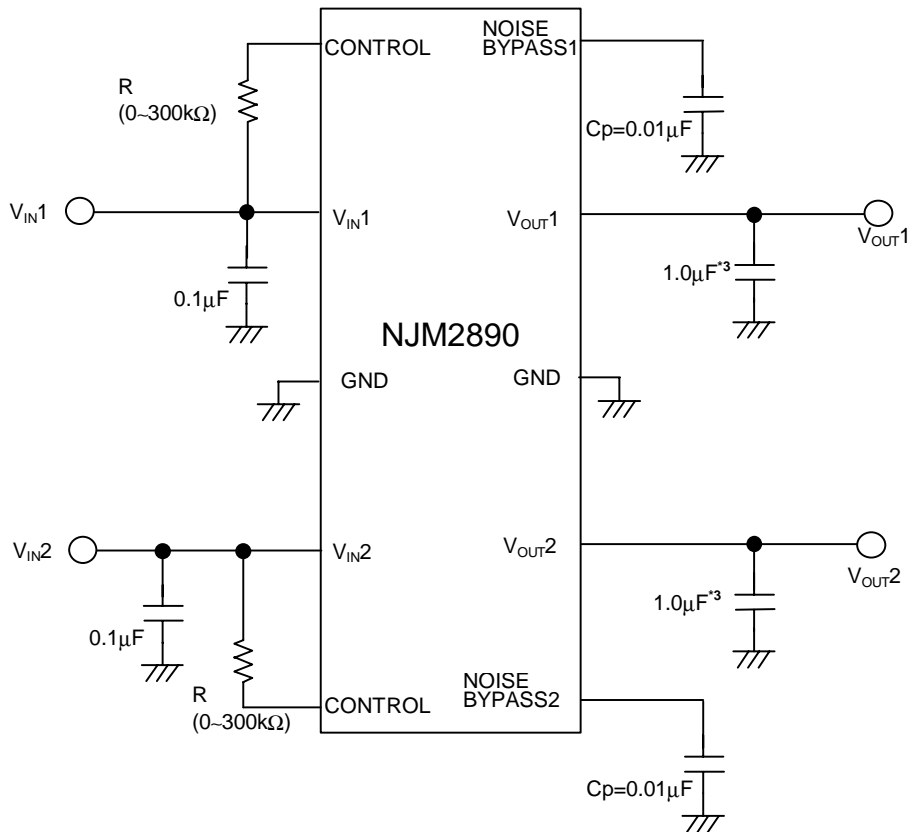

\*3  $V_o \leq 2.6V$  version:  $C_o = 2.2\mu F$

Connect control terminal to  $V_{IN}$  terminal

The quiescent current can be reduced by using a resistance "R". Instead, it increases the minimum operating voltage. For further information, please refer to Figure "Output Voltage vs. Control Voltage".

② In use of ON/OFF CONTROL:

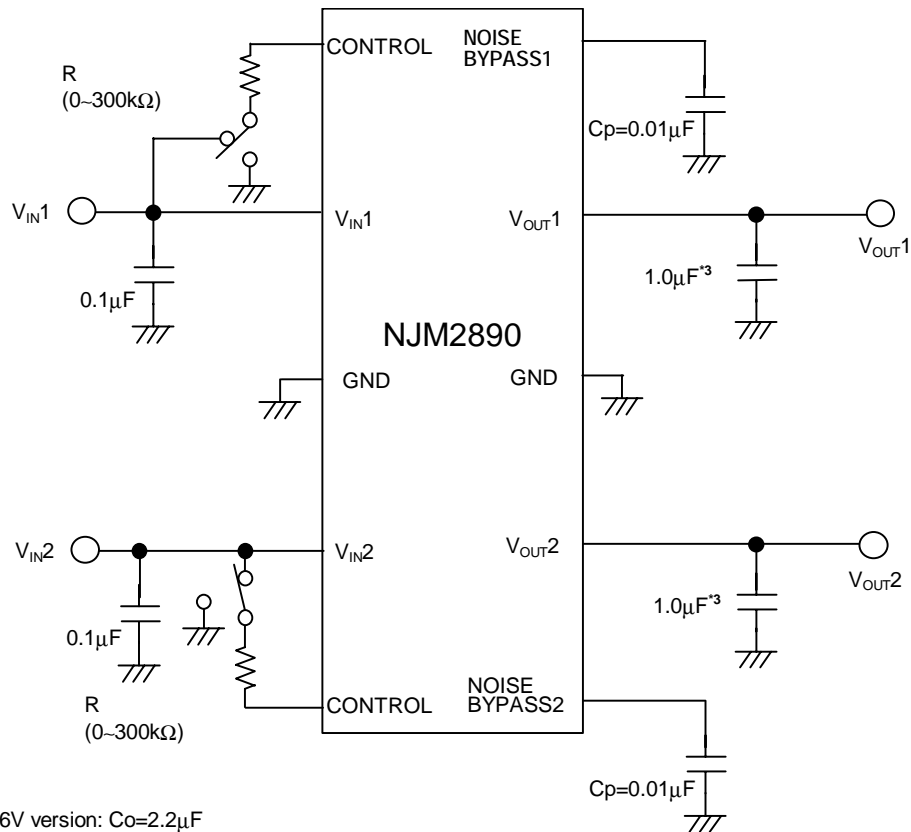

\*3  $V_o \leq 2.6V$  version:  $C_o = 2.2\mu F$

State of control terminal:

- “H” → output is enabled.
- “L” or “open” → output is disabled.

**\*Noise bypass Capacitance  $C_p$**

Noise bypass capacitance  $C_p$  reduces noise generated by band-gap reference circuit.

Noise level and ripple rejection will be improved when larger  $C_p$  is used.

Use of smaller  $C_p$  value may cause oscillation.

Use the  $C_p$  value of  $0.01\mu F$  greater to avoid the problem.

## ■ ELECTRICAL CHARACTERISTICS

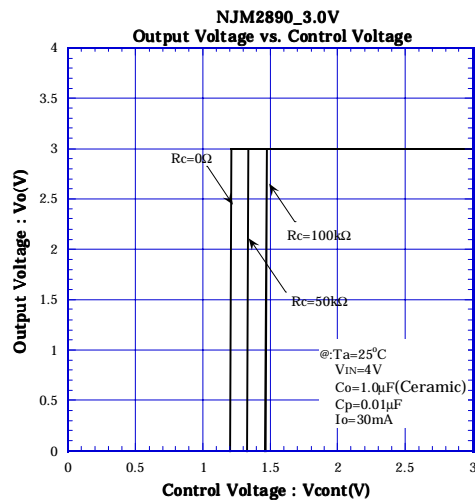
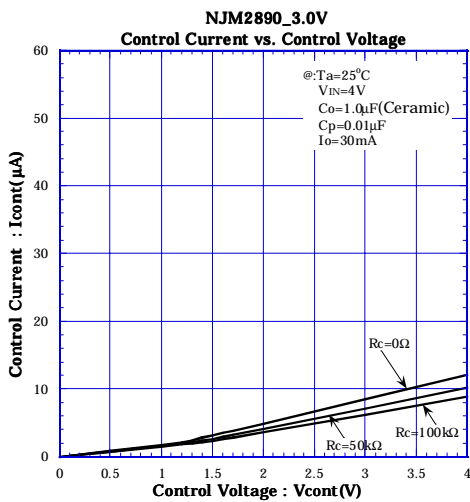
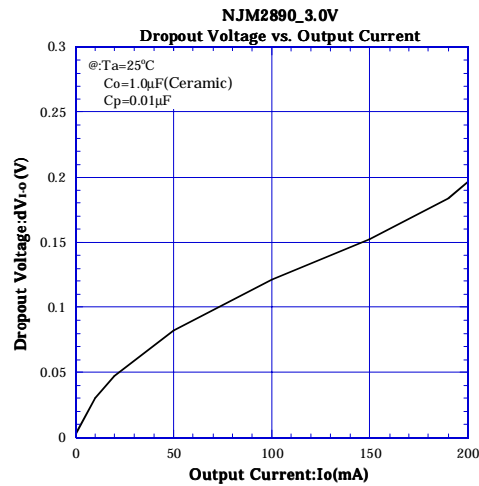
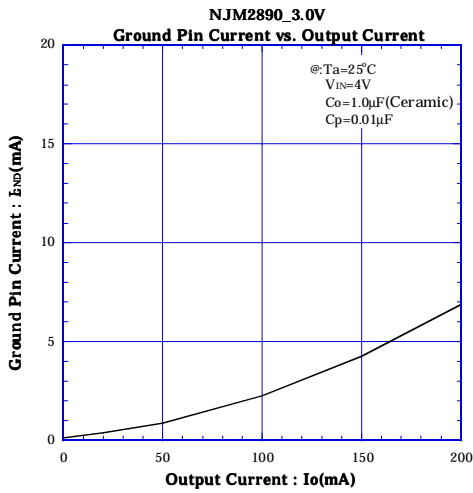
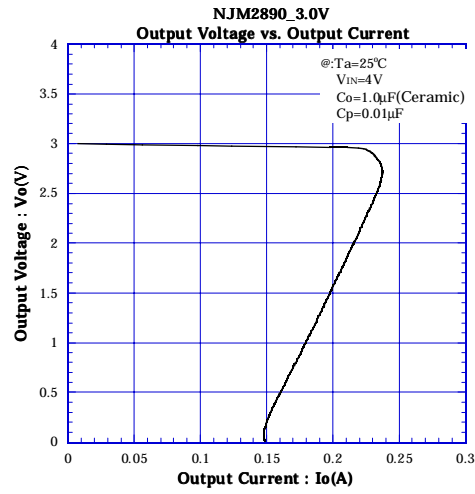
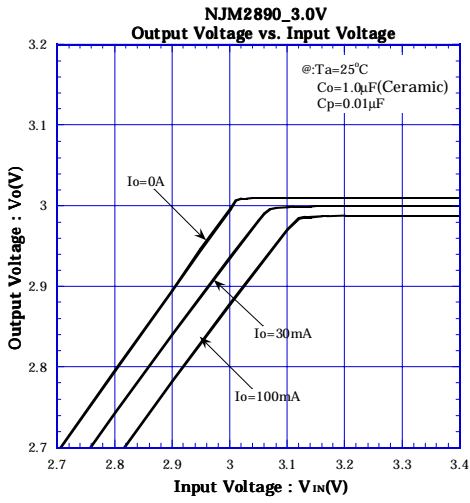

## ELECTRICAL CHARACTERISTICS

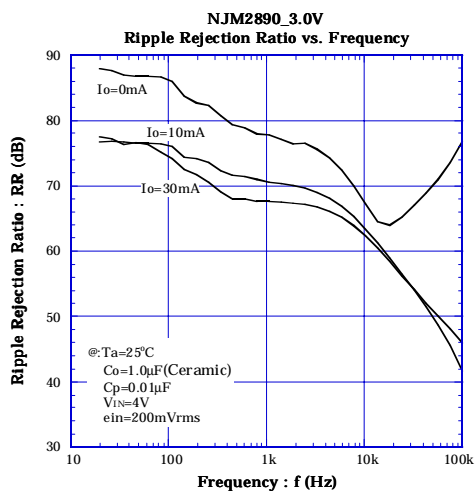
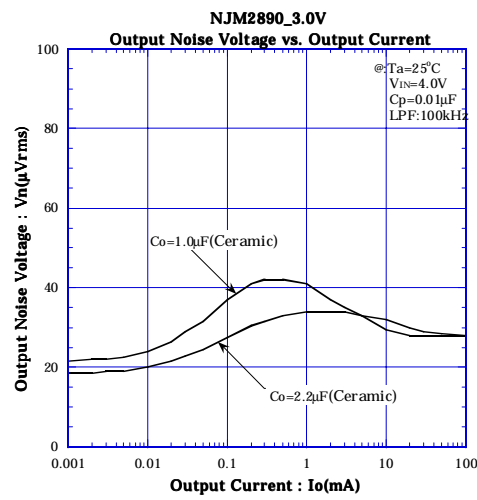
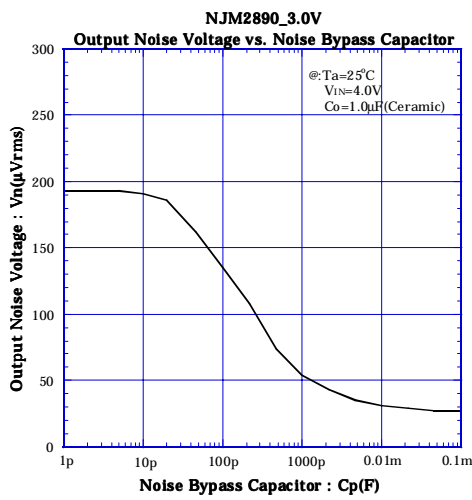
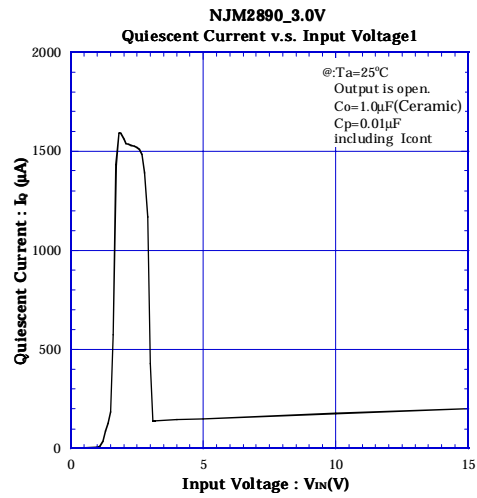
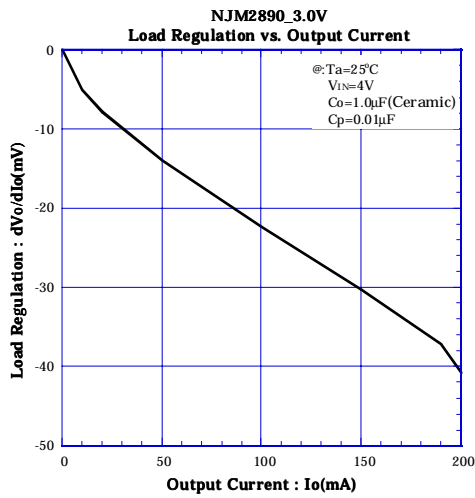

## ■ ELECTRICAL CHARACTERISTICS

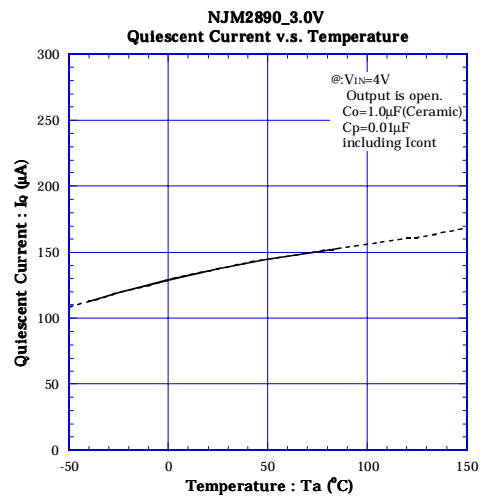
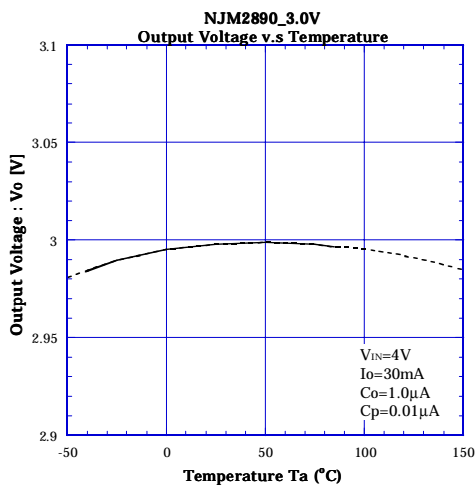
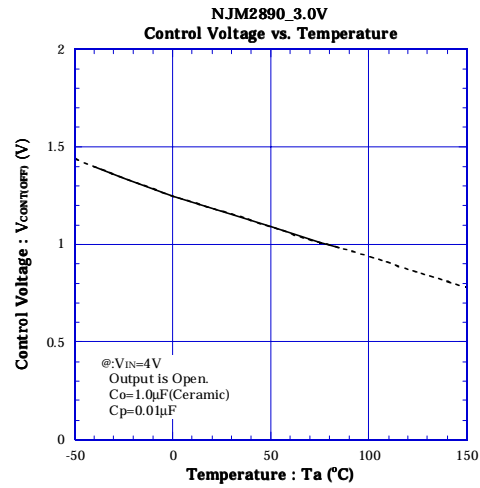
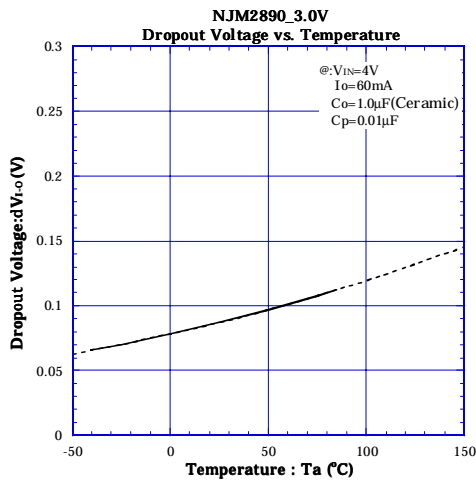
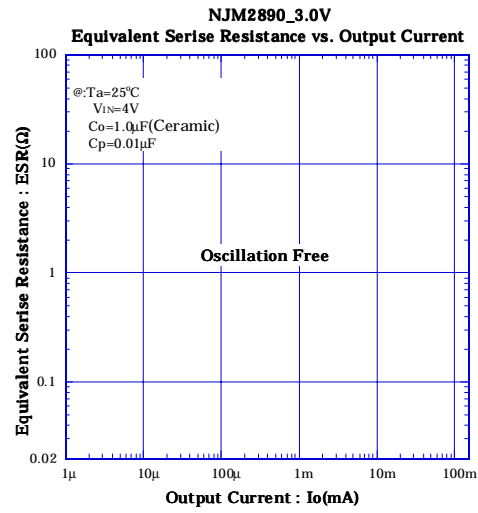
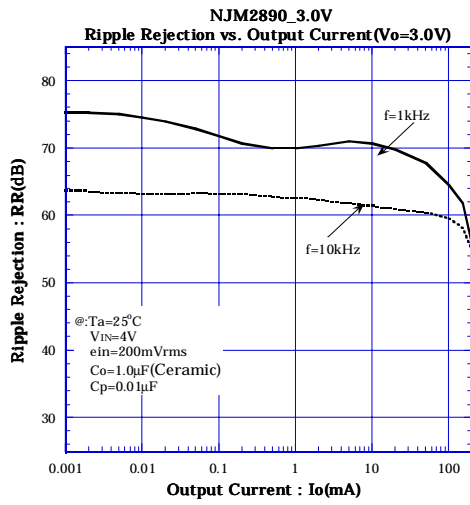



## ELECTRICAL CHARACTERISTICS

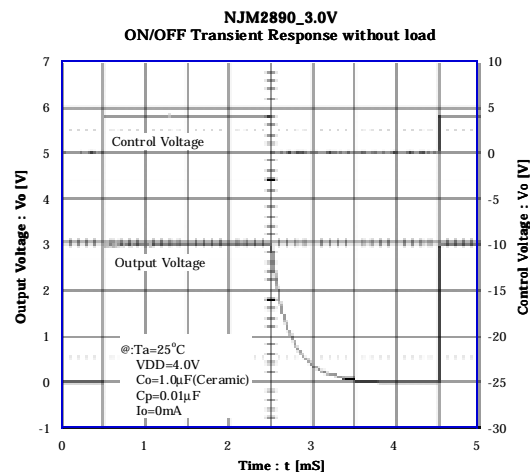
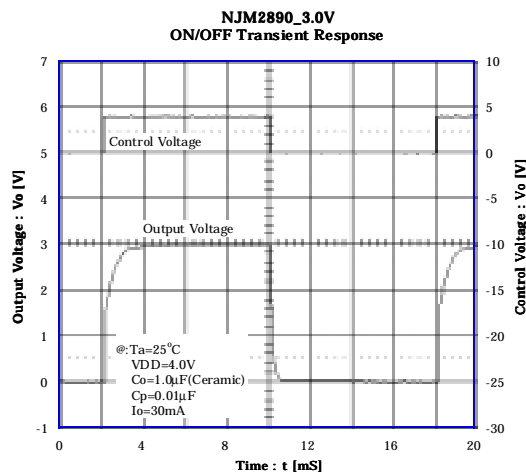
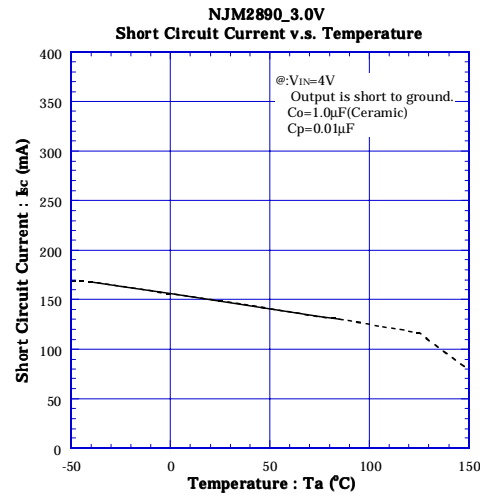
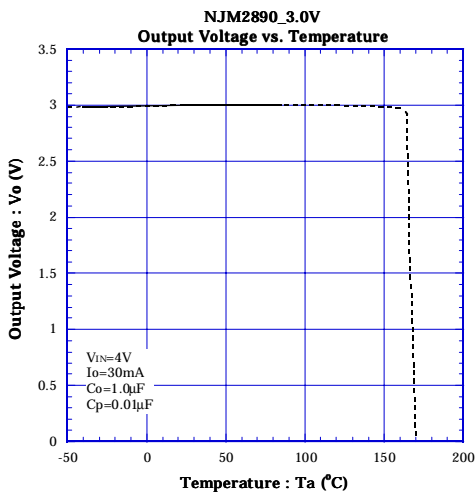
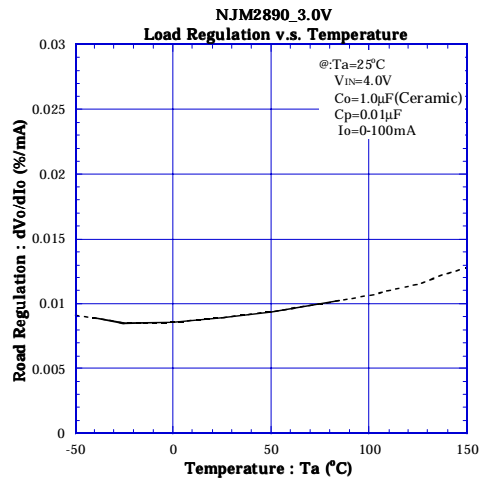
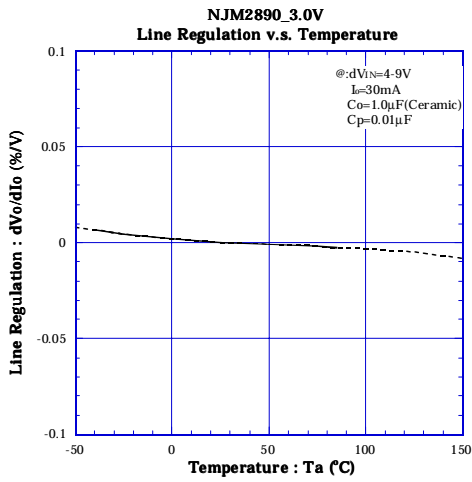

## ■ ELECTRICAL CHARACTERISTICS

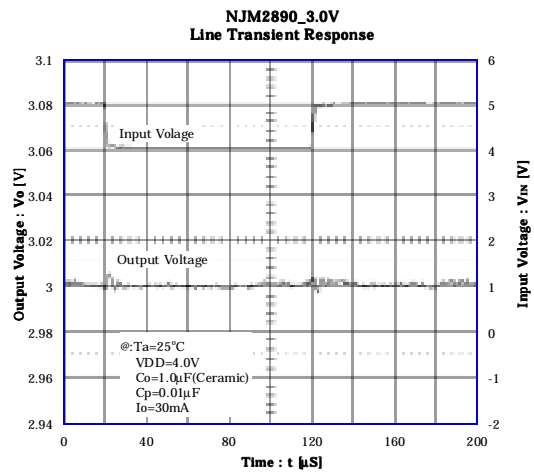
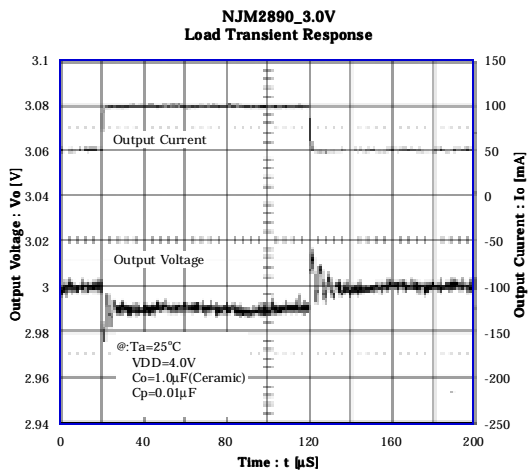

**[CAUTION]**  
 The specifications on this databook are only given for information, without any guarantee as regards either mistakes or omissions. The application circuits in this databook are described only to show representative usages of the product and not intended for the guarantee or permission of any right including the industrial rights.