

FEATURES

- **LOW NOISE FIGURE:**
NF = 0.8 dB typical at $f = 4$ GHz
- **HIGH ASSOCIATED GAIN:**
GA = 12.0 dB typical at $f = 4$ GHz
- **LG = 1.0 μm , WG = 400 μm**

DESCRIPTION

NE76100 is a high performance gallium arsenide metal semiconductor field effect transistor chip. Its low noise figure makes this device appropriate for use in the second or third stages of low noise amplifiers operating in the 1-12 GHz frequency range. The device is fabricated using ion implantation for improved RF and DC performance, reliability, and uniformity. The NE76100 is suitable for a wide variety of commercial and industrial applications.

NEC's stringent quality assurance and test procedures assure the highest reliability and performance.

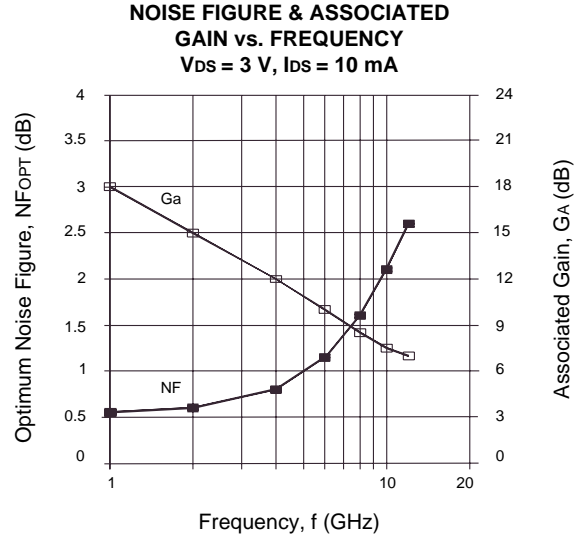

ELECTRICAL CHARACTERISTICS ($T_A = 25^\circ\text{C}$)

PART NUMBER PACKAGE OUTLINE			NE76100 00 (CHIP)		
SYMBOLS	PARAMETERS AND CONDITIONS	UNITS	MIN	TYP	MAX
NFOPT ¹	Noise Figure at $V_{DS} = 3$ V, $I_D = 10$ mA, $f = 4$ GHz	dB		0.8	1.4
GA ¹	Associated Gain at $V_{DS} = 3$ V, $I_D = 10$ mA, $f = 4$ GHz	dB		12.0	
P _{1dB}	Output Power at 1 dB Gain Compression Point, $f = 4$ GHz $V_{DS} = 3$ V, $I_{DS} = 10$ mA $V_{DS} = 3$ V, $I_{DS} = 30$ mA	dBm dBm		12.5 15.0	
G _{1dB}	Gain at P _{1dB} , $f = 4$ GHz $V_{DS} = 3$ V, $I_{DS} = 10$ mA $V_{DS} = 3$ V, $I_{DS} = 30$ mA	dB dB		11.5 13.5	
I _{DSS}	Saturated Drain Current at $V_{DS} = 3$ V, $V_{GS} = 0$	mA	30	60	100
V _P	Pinch Off Voltage at $V_{DS} = 3$ V, $I_D = 100$ mA	V	-3.0	-1.1	-0.5
g _m	Transconductance at $V_{DS} = 3$ V, $I_D = 10$ mA	mS	20	45	
I _{GSO}	Gate to Source Leak Current at $V_{GS} = -5$ V	μA		1.0	10
R _{TH} ²	Thermal Resistance	$^\circ\text{C}/\text{W}$			190

Notes:

1. RF performance is determined by packaging and testing 10 samples per wafer. Wafer rejection criteria for standard devices is 2 rejects for 10 samples.
2. Chip mounted on an infinite heat sink.

ABSOLUTE MAXIMUM RATINGS¹ (T_A = 25°C)

SYMBOLS	PARAMETERS	UNITS	RATINGS
V _{DS}	Drain to Source Voltage	V	5
V _{GD}	Gate to Drain Voltage	V	-6
V _{GS}	Gate to Source Voltage	V	-5
I _{DS}	Drain Current	mA	I _{DSS}
T _{CH}	Channel Temperature	°C	175
T _{STG}	Storage Temperature	°C	-65 to +175
P _T ²	Total Power Dissipation	mW	350

Notes:

1. Operation in excess of anyone of these parameters may result in permanent damage.
2. Mounted on an infinite heat sink.

TYPICAL NOISE PARAMETERS (T_A = 25°C)

V_{DS} = 3 V, I_{DS} = 10 mA

FREQ. (GHz)	NF _{OPT} (dB)	GA (dB)	Γ _{OPT}		Rn/50
			MAG	ANG	
1.0	0.55	18.0	0.90	16	0.50
2.0	0.60	15.0	0.82	34	0.48
4.0	0.80	12.0	0.70	65	0.45
6.0	1.15	10.0	0.60	95	0.39
8.0	1.60	8.5	0.52	122	0.38
10.0	2.10	7.5	0.50	150	0.32
12.0	2.60	7.0	0.50	171	0.27

Includes effects from wirebonds. See S-Parameter data for details.

TYPICAL PERFORMANCE CURVES (T_A = 25°C)

TOTAL POWER DISSIPATION vs. AMBIENT TEMPERATURE

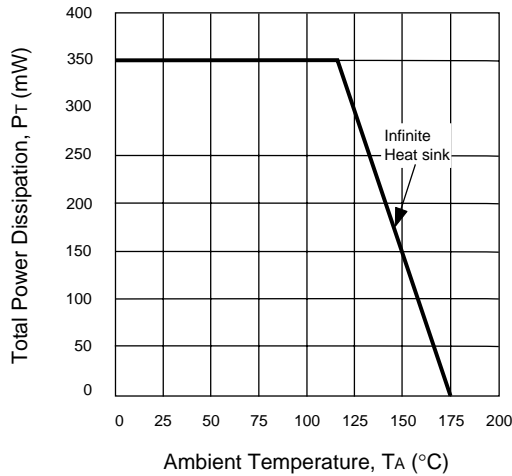

NOISE FIGURE AND ASSOCIATED GAIN vs. DRAIN CURRENT
V_{DS} = 3 V, f = 4 GHz

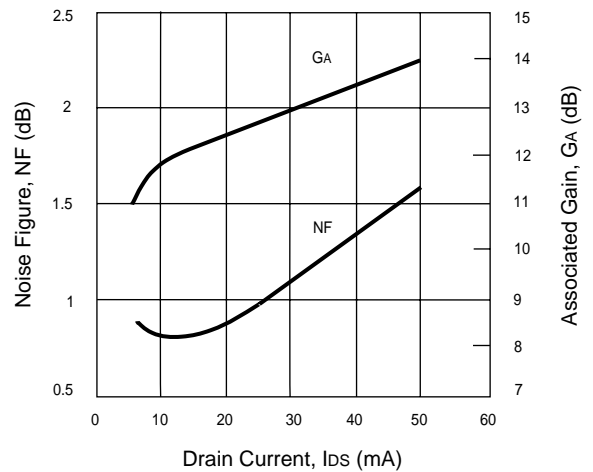

DRAIN CURRENT vs. DRAIN TO SOURCE VOLTAGE

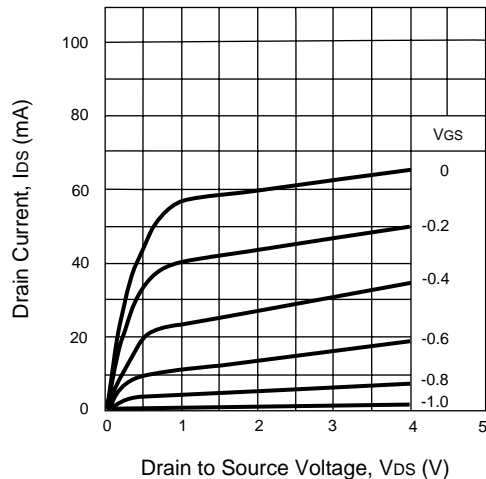

TRANSCONDUCTANCE vs. DRAIN CURRENT V_{DS} = 3 V

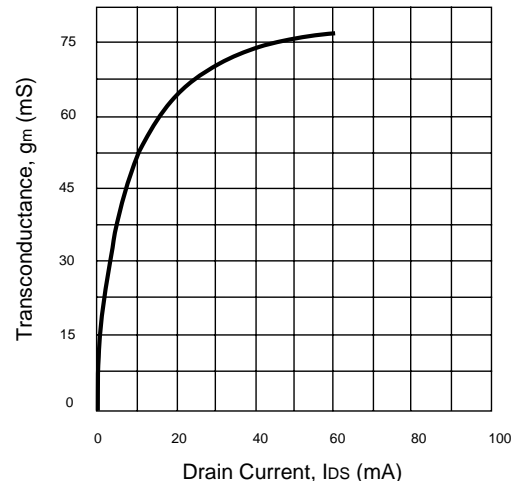

TYPICAL SCATTERING PARAMETERS² (T_A = 25°C)

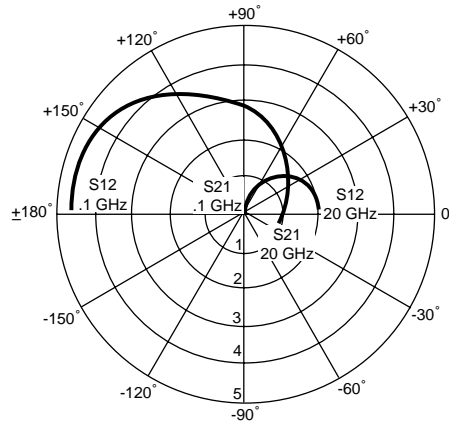
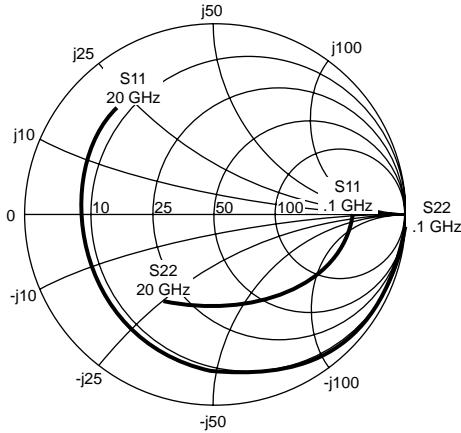

V_{DS} = 3 V, I_{DS} = 10 mA

FREQUENCY (GHz)	S ₁₁		S ₂₁		S ₁₂		S ₂₂		K	S ₂₁ (dB)	MAG ¹ (dB)
	MAG	ANG	MAG	ANG	MAG	ANG	MAG	ANG			
0.1	0.99	-2.3	3.782	178.2	0.004	86.7	0.769	-1.2	0.052	11.6	30.1
0.2	0.999	-4.5	3.779	176.3	0.007	86.4	0.769	-2.3	0.037	11.5	27.1
0.5	0.996	-11.3	3.763	170.9	0.018	83.1	0.767	-5.7	0.045	11.5	23.1
1.0	0.986	-22.5	3.707	161.9	0.036	76.9	0.759	-11.4	0.076	11.2	18.4
1.5	0.971	-33.3	3.619	153.1	0.053	70.8	0.747	16.8	0.110	11.4	20.1
2.0	0.951	-43.9	3.505	144.7	0.068	65.0	0.731	-22.0	0.145	10.9	17.1
3.0	0.905	-63.6	3.233	128.9	0.093	54.5	0.694	-31.5	0.214	10.2	15.4
4.0	0.859	-81.4	2.941	114.6	0.112	45.5	0.657	-39.7	0.281	9.4	14.2
5.0	0.818	-97.3	2.662	101.9	0.126	37.9	0.624	-46.8	0.347	8.5	13.3
6.0	0.784	-111.4	2.411	90.3	0.135	31.5	0.598	-53.1	0.410	7.6	12.5
7.0	0.759	-124.2	2.190	79.8	0.141	26.1	0.577	-58.9	0.470	6.8	11.9
8.0	0.739	-135.6	1.999	70.1	0.145	21.6	0.562	-64.2	0.526	6.0	11.4
9.0	0.726	-146.0	1.833	61.1	0.148	17.7	0.552	-69.3	0.578	5.3	10.9
10.0	0.718	-155.4	1.688	52.7	0.149	14.3	0.547	-74.2	0.626	4.5	10.5
11.0	0.713	-164.0	1.562	44.7	0.149	11.4	0.545	-79.0	0.669	3.9	10.2
12.0	0.711	-172.0	1.449	37.2	0.149	8.8	0.545	-83.7	0.708	3.2	9.9
13.0	0.712	-179.3	1.349	29.9	0.148	6.7	0.548	-88.3	0.741	2.6	9.6
14.0	0.715	173.9	1.259	23.0	0.147	4.8	0.554	-92.9	0.770	2.0	9.3
15.0	0.719	167.5	1.177	16.4	0.146	3.2	0.561	-97.5	0.793	1.4	9.1
16.0	0.725	161.6	1.102	10.0	0.144	1.8	0.569	-102.1	0.811	0.8	8.8
17.0	0.732	156.1	1.033	3.8	0.142	0.7	0.579	-106.7	0.824	0.3	8.6
18.0	0.739	150.9	0.968	-2.1	0.141	-0.2	0.589	-111.2	0.831	-0.3	8.4
19.0	0.747	146.0	0.908	-7.8	0.139	-0.9	0.601	-115.7	0.833	-0.8	8.1
20.0	0.755	141.4	0.851	-13.4	0.138	-1.5	0.613	-120.1	0.830	-1.4	7.9

Note:

1. Gain Calculations:

$$MAG = \frac{|S_{21}|}{|S_{12}|} (K \pm \sqrt{K^2 - 1})$$

. When K ≤ 1, MAG is undefined and MSG values are used. $MSG = \frac{|S_{21}|}{|S_{12}|}$, $K = \frac{1 + |\Delta|^2 - |S_{11}|^2 - |S_{22}|^2}{2 |S_{12} S_{21}|}$, $\Delta = S_{11} S_{22} - S_{21} S_{12}$

MAG = Maximum Available Gain
MSG = Maximum Stable Gain

2. S-parameters include bond wires as follows:

- GATE: TOTAL 1 WIRE(S), 1 PER BOND PAD, 0.0134" (340 μm) LONG.
- DRAIN: TOTAL 2 WIRE(S), 1 PER BOND PAD, 0.0188" (477 μm) LONG.
- SOURCE: TOTAL 4 WIRE(S), 2 PER SIDE, 0.0114" (286 μm) LONG.
- WIRE: 0.0007" (17.8 μm) DIA. GOLD.

TYPICAL SCATTERING PARAMETERS² (T_A = 25°C)

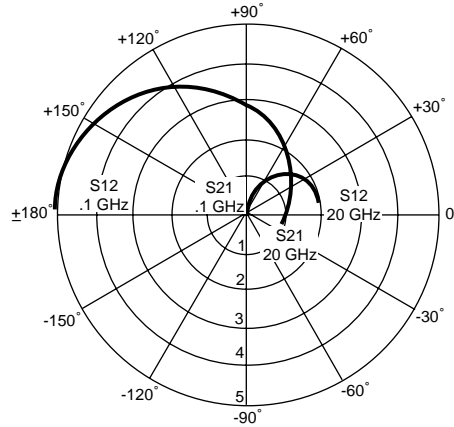
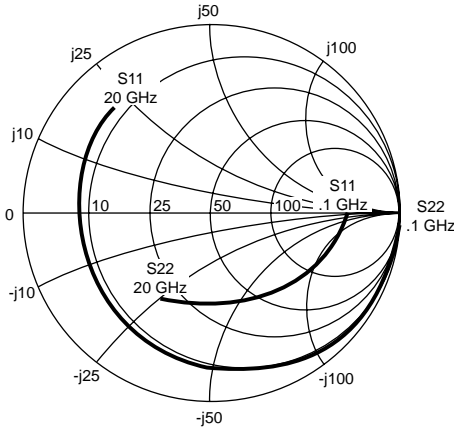

V_{DS} = 3 V, I_{DS} = 20 mA

FREQUENCY (GHz)	S ₁₁		S ₂₁		S ₁₂		S ₂₂		K	S ₂₁ (dB)	MAG ¹ (dB)
	MAG	ANG	MAG	ANG	MAG	ANG	MAG	ANG			
0.1	0.999	-2.5	4.692	178.0	0.003	86.5	0.713	-1.2	0.053	13.4	31.4
0.2	0.999	-5.1	4.668	176.1	0.007	86.2	0.712	-2.5	0.038	13.4	28.4
0.5	0.995	-12.7	4.662	170.3	0.017	82.7	0.710	-6.2	0.047	13.4	24.4
1.0	0.983	-25.2	4.572	160.7	0.033	76.2	0.701	-12.2	0.081	13.2	21.4
1.5	0.965	-37.3	4.435	151.5	0.048	69.8	0.686	-17.9	0.117	12.9	19.7
2.0	0.943	-48.8	4.261	142.6	0.061	63.8	0.669	-23.3	0.154	12.6	18.4
3.0	0.893	-70.1	3.860	126.5	0.083	53.3	0.629	-33.0	0.227	11.7	16.7
4.0	0.845	-88.8	3.451	112.3	0.098	44.7	0.592	-41.1	0.299	10.8	15.4
5.0	0.805	-105.2	3.078	99.7	0.109	37.8	0.560	-48.0	0.368	9.8	14.5
6.0	0.774	-119.5	2.754	88.6	0.117	32.2	0.536	-54.1	0.434	8.8	13.7
7.0	0.752	-132.1	2.477	78.5	0.122	27.7	0.519	-59.6	0.496	7.9	13.1
8.0	0.736	-143.3	2.242	69.2	0.125	23.9	0.507	-64.8	0.554	7.0	12.5
9.0	0.726	-153.3	2.042	60.6	0.127	20.8	0.500	-69.8	0.606	6.2	12.0
10.0	0.720	-162.3	1.870	52.5	0.129	18.2	0.497	-74.7	0.654	5.4	11.6
11.0	0.717	-170.6	1.722	44.9	0.130	16.1	0.497	-79.4	0.696	4.7	11.2
12.0	0.717	-178.1	1.592	37.7	0.131	14.2	0.500	-84.2	0.732	4.0	10.9
13.0	0.719	-174.9	1.477	30.7	0.131	12.7	0.505	-88.8	0.762	3.4	10.5
14.0	0.722	-168.5	1.374	24.1	0.131	11.4	0.511	-93.5	0.787	2.8	10.2
15.0	0.727	-162.5	1.282	17.7	0.131	10.3	0.519	-98.1	0.805	2.2	9.9
16.0	0.733	-156.9	1.197	11.5	0.131	9.4	0.529	-102.7	0.816	1.6	9.6
17.0	0.739	-151.6	1.120	5.6	0.131	8.6	0.539	-107.2	0.823	1.0	9.3
18.0	0.746	-146.7	1.049	-0.2	0.131	7.9	0.551	-111.7	0.823	0.4	9.0
19.0	0.754	-142.1	0.983	-5.7	0.132	7.4	0.563	-116.2	0.818	-0.1	8.7
20.0	0.761	-137.7	0.921	-11.1	0.132	6.9	0.575	-120.6	0.808	-0.7	8.4

Note:

1. Gain Calculations:

$$MAG = \frac{|S_{21}|}{|S_{12}|} (K \pm \sqrt{K^2 - 1})$$

When $K \leq 1$, MAG is undefined and MSG values are used. $MSG = \frac{|S_{21}|}{|S_{12}|}$, $K = \frac{1 + |\Delta|^2 - |S_{11}|^2 - |S_{22}|^2}{2 |S_{12} S_{21}|}$, $\Delta = S_{11} S_{22} - S_{21} S_{12}$

MAG = Maximum Available Gain

MSG = Maximum Stable Gain

2. S-parameters include bond wires as follows:

- GATE: TOTAL 1 WIRE(S), 1 PER BOND PAD, 0.0134" (340 μm) LONG.
- DRAIN: TOTAL 2 WIRE(S), 1 PER BOND PAD, 0.0188" (477 μm) LONG.
- SOURCE: TOTAL 4 WIRE(S), 2 PER SIDE, 0.0114" (286 μm) LONG.
- WIRE: 0.0007" (17.8 μm) DIA. GOLD.

TYPICAL SCATTERING PARAMETERS² (T_A = 25°C)

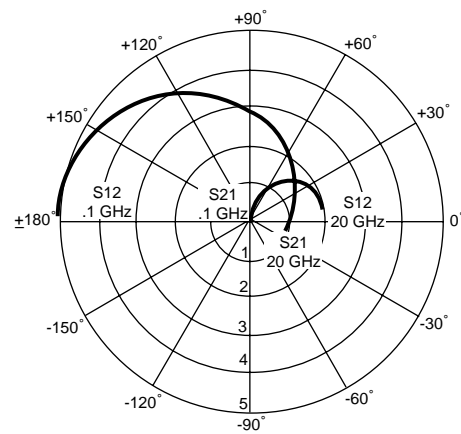
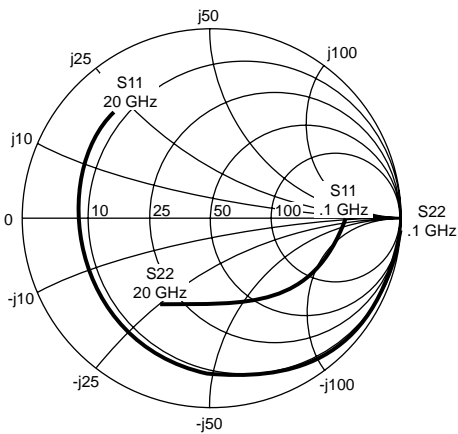

V_{DS} = 3 V, I_{DS} = 30 mA

FREQUENCY (GHz)	S ₁₁		S ₂₁		S ₁₂		S ₂₂		K	S ₂₁ (dB)	MAG ¹ (dB)
	MAG	ANG	MAG	ANG	MAG	ANG	MAG	ANG			
0.1	0.999	-2.7	5.142	178.0	0.003	86.5	0.694	-1.3	0.054	14.2	32.0
0.2	0.999	-5.4	5.137	176.0	0.006	86.1	0.693	-2.5	0.039	14.2	29.0
0.5	0.995	-13.4	5.104	169.9	0.016	82.5	0.690	-6.3	0.049	14.2	25.0
1.0	0.982	-26.6	4.995	160.1	0.031	75.7	0.680	-12.5	0.083	14.0	22.0
1.5	0.963	-39.3	4.827	150.6	0.045	69.2	0.665	-18.3	0.120	13.7	20.3
2.0	0.939	-51.4	4.619	141.5	0.058	63.2	0.647	-23.7	0.158	13.3	19.0
3.0	0.887	-73.4	4.146	125.2	0.078	52.7	0.606	-33.3	0.233	12.4	17.3
4.0	0.840	-92.5	3.676	111.0	0.092	44.4	0.569	-41.2	0.307	11.3	16.0
5.0	0.802	-109.0	3.256	98.6	0.102	37.8	0.538	-48.0	0.378	10.3	15.1
6.0	0.773	-123.3	2.896	87.6	0.108	32.6	0.516	-53.9	0.445	9.2	14.3
7.0	0.752	-135.8	2.594	77.6	0.113	28.5	0.500	-59.4	0.508	8.3	13.6
8.0	0.738	-146.8	2.340	68.6	0.116	25.1	0.490	-64.5	0.565	7.4	13.1
9.0	0.730	-156.6	2.125	60.1	0.118	22.4	0.485	-69.5	0.618	6.5	12.6
10.0	0.725	-165.5	1.941	52.2	0.120	20.2	0.483	-74.3	0.664	5.8	12.1
11.0	0.723	-173.5	1.783	44.7	0.121	18.4	0.484	-79.1	0.705	5.0	11.7
12.0	0.723	-179.1	1.646	37.6	0.122	16.8	0.487	-83.8	0.739	4.3	11.3
13.0	0.726	-172.4	1.524	30.8	0.123	15.6	0.493	-88.5	0.766	3.7	10.9
14.0	0.730	-166.1	1.417	24.3	0.124	14.5	0.500	-93.2	0.787	3.0	10.6
15.0	0.735	-160.3	1.320	18.0	0.124	13.6	0.508	-97.8	0.802	2.4	10.3
16.0	0.740	-154.8	1.232	11.9	0.125	12.9	0.518	-102.5	0.810	1.8	9.9
17.0	0.747	-149.7	1.151	6.0	0.126	12.2	0.529	-107.0	0.812	1.2	9.6
18.0	0.754	-144.9	1.077	0.4	0.127	11.7	0.541	-111.6	0.808	0.6	9.3
19.0	0.761	-140.4	1.009	-5.1	0.128	11.2	0.553	-116.1	0.800	0.1	9.0
20.0	0.768	-136.1	0.945	-10.4	0.129	10.8	0.566	-120.5	0.787	-0.5	8.7

Note:

1. Gain Calculations:

$$\text{MAG} = \frac{|S_{21}|}{|S_{12}|} \left(K \pm \sqrt{K^2 - 1} \right). \text{ When } K \leq 1, \text{ MAG is undefined and MSG values are used. } \text{MSG} = \frac{|S_{21}|}{|S_{12}|}, K = \frac{1 + |\Delta|^2 - |S_{11}|^2 - |S_{22}|^2}{2 |S_{12} S_{21}|}, \Delta = S_{11} S_{22} - S_{21} S_{12}$$

MAG = Maximum Available Gain

MSG = Maximum Stable Gain

2. S-parameters include bond wires as follows:

GATE: TOTAL 1 WIRE(S), 1 PER BOND PAD, 0.0134" (340 μm) LONG.
 DRAIN: TOTAL 2 WIRE(S), 1 PER BOND PAD, 0.0188" (477 μm) LONG.
 SOURCE: TOTAL 4 WIRE(S), 2 PER SIDE, 0.0114" (286 μm) LONG.
 WIRE: 0.0007" (17.8 μm) DIA. GOLD.

TYPICAL SCATTERING PARAMETERS² (T_A = 25°C)

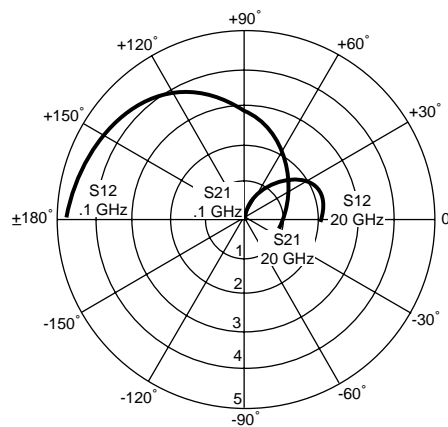
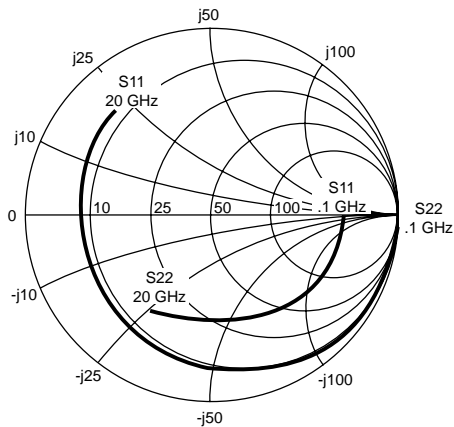

V_{DS} = 3 V, I_{DS} = 40 mA

FREQUENCY (GHz)	S ₁₁		S ₂₁		S ₁₂		S ₂₂		K	S ₂₁ (dB)	MAG ¹ (dB)
	MAG	ANG	MAG	ANG	MAG	ANG	MAG	ANG			
0.1	0.999	-2.8	5.433	177.9	0.003	86.4	0.685	-1.3	0.054	14.7	32.4
0.2	0.999	-5.6	5.428	175.9	0.006	86.0	0.684	-2.5	0.039	14.7	29.4
0.5	0.995	-13.9	5.391	169.7	0.015	82.3	0.681	-6.3	0.049	14.6	25.4
1.0	0.981	-27.5	5.267	159.6	0.030	75.5	0.671	-12.5	0.085	14.4	22.4
1.5	0.961	-40.6	5.079	150.0	0.044	69.0	0.655	-18.3	0.123	14.1	20.7
2.0	0.937	-53.0	4.846	140.8	0.055	62.9	0.637	-23.7	0.162	13.7	19.4
3.0	0.885	-75.5	4.325	124.4	0.074	52.6	0.596	-33.1	0.239	12.7	17.7
4.0	0.838	-94.8	3.815	110.2	0.087	44.4	0.559	-40.8	0.313	11.6	16.4
5.0	0.800	-111.3	3.365	97.8	0.096	38.1	0.530	-47.4	0.385	10.5	15.4
6.0	0.773	-125.6	2.984	86.9	0.102	33.2	0.508	-53.2	0.453	9.5	14.7
7.0	0.753	-138.0	2.666	77.1	0.107	29.4	0.494	-58.5	0.516	8.5	14.0
8.0	0.741	-148.9	2.400	68.1	0.110	26.3	0.484	-63.6	0.573	7.6	13.4
9.0	0.733	-158.6	2.176	59.8	0.112	23.9	0.480	-68.6	0.625	6.8	12.9
10.0	0.728	-167.3	1.985	51.9	0.114	21.9	0.479	-73.4	0.670	6.0	12.4
11.0	0.727	-175.2	1.821	44.5	0.115	20.3	0.480	-78.2	0.709	5.2	12.0
12.0	0.728	177.6	1.679	37.5	0.117	18.9	0.484	-82.9	0.740	4.5	11.6
13.0	0.731	170.9	1.554	30.7	0.118	17.8	0.490	-87.7	0.765	3.8	11.2
14.0	0.734	164.7	1.442	24.3	0.119	16.9	0.497	-92.4	0.784	3.2	10.8
15.0	0.739	159.0	1.343	18.0	0.120	16.2	0.506	-97.1	0.795	2.6	10.5
16.0	0.745	153.6	1.252	12.0	0.121	15.5	0.516	-101.7	0.800	2.0	10.1
17.0	0.751	148.6	1.170	6.2	0.123	14.9	0.527	-106.3	0.799	1.4	9.8
18.0	0.758	143.9	1.094	0.5	0.124	14.4	0.538	-110.9	0.793	0.8	9.5
19.0	0.765	139.4	1.024	-4.9	0.125	13.9	0.551	-115.4	0.782	0.2	9.1
20.0	0.772	135.2	0.959	-10.2	0.127	13.5	0.563	-119.9	0.767	-0.4	8.8

Note:

1. Gain Calculations:

$$MAG = \frac{|S_{21}|}{|S_{12}|} (K \pm \sqrt{K^2 - 1})$$

. When K ≤ 1, MAG is undefined and MSG values are used. $MSG = \frac{|S_{21}|}{|S_{12}|}$, $K = \frac{1 + |\Delta|^2 - |S_{11}|^2 - |S_{22}|^2}{2 |S_{12} S_{21}|}$, $\Delta = S_{11} S_{22} - S_{21} S_{12}$

MAG = Maximum Available Gain

MSG = Maximum Stable Gain

2. S-parameters include bond wires as follows:

- GATE: TOTAL 1 WIRE(S), 1 PER BOND PAD, 0.0134" (340 μm) LONG.
- DRAIN: TOTAL 2 WIRE(S), 1 PER BOND PAD, 0.0188" (477 μm) LONG.
- SOURCE: TOTAL 4 WIRE(S), 2 PER SIDE, 0.0114" (286 μm) LONG.
- WIRE: 0.0007" (17.8 μm) DIA. GOLD.

NE76100 LINEAR MODEL

SCHEMATIC

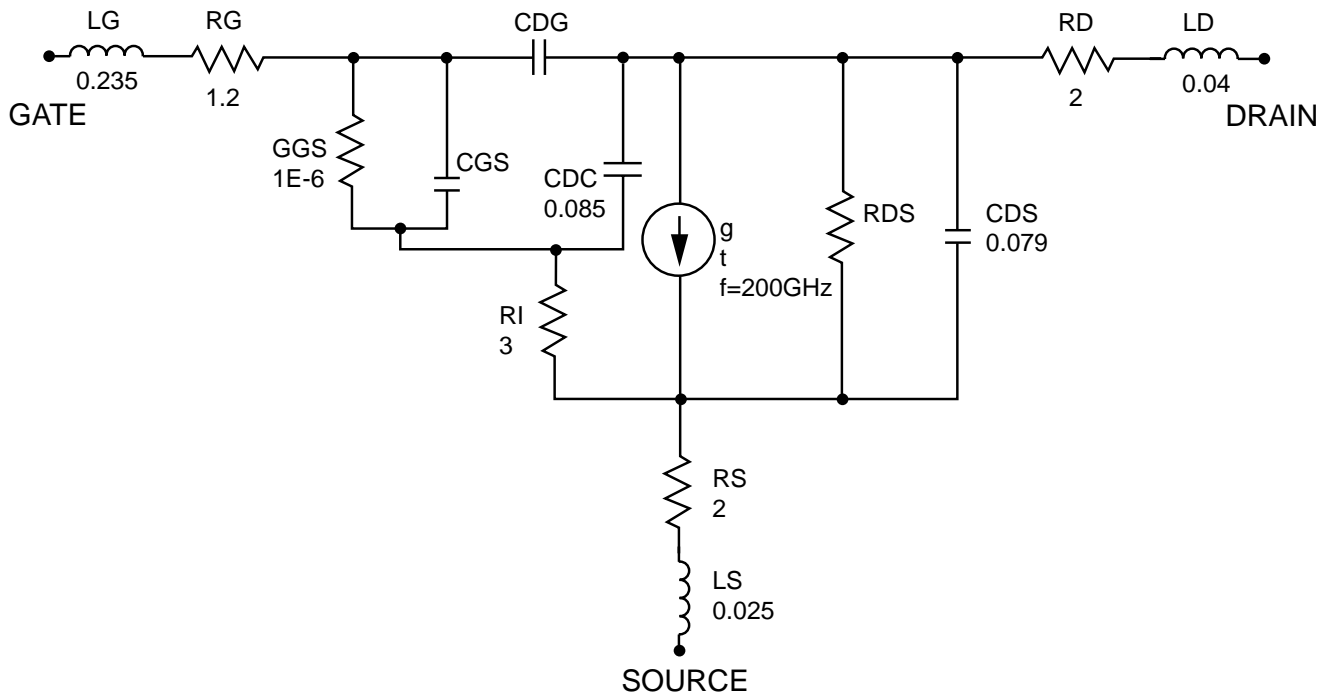

BIAS DEPENDANT MODEL PARAMETERS

Parameters	3 V, 10 mA	3 V, 20 mA	3 V, 30 mA	3 V, 40 mA
g	48 mS	63 mS	70 mS	76 mS
t	5 pSec	4.5 pSec	4.5 pSec	4 pSec
RDS	350 ohms	260 ohms	240 ohms	230 ohms
CGS	0.45 pF	0.52 pF	0.57 pF	0.61pF
CDG	0.07 pF	0.068 pF	0.065 pF	0.061 pF

UNITS

Parameter	Units
capacitance	picofarads
inductance	nanohenries
resistance	ohms
conductance	millisiemens
time	picoseconds
frequency	gigahertz

MODEL RANGE

Frequency: 0.1 to 20 GHz
 Bias: $V_{DS} = 3\text{ V}$, $I_D = 10, 20, 30, 40\text{ mA}$
 Date: 10/23/96

NE76100

OUTLINE DIMENSIONS (Units in μm)

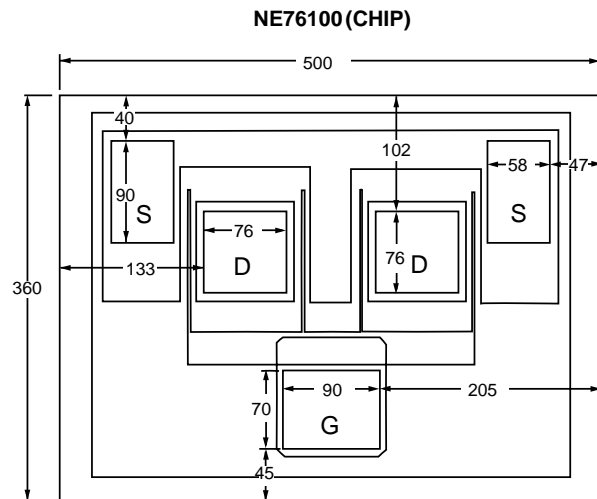

Chip Thickness: 140 μm

Note:

All dimensions are typical unless otherwise specified.

ORDERING INFORMATION

PART NUMBER	IDSS SELECTION
NE76100	30 to 100 mA (Standard)
NE76100N	30 to 60
NE76100M	60 to 100