



NPN SILICON HIGH FREQUENCY TRANSISTOR

NE661M04

FEATURES

- **HIGH GAIN BANDWIDTH:** $f_T = 25$ GHz
- **HIGH POWER GAIN:** $IS_{21EI}^2 = 17$ dB TYP at 2 GHz
- **LOW NOISE FIGURE:** $NF = 1.2$ dB at 2 GHz
- **HIGH MAXIMUM STABLE GAIN:** 22 dB @ 2 GHz
- **NEW LOW PROFILE M04 PACKAGE:**
SOT-343 footprint, with a height of just 0.59 mm.
Flat Lead Style for better RF performance.

DESCRIPTION

NEC's NE661M04 is fabricated using NEC's UHS0 25 GHz f_T wafer process. With a typical transition frequency of 25 GHz the NE661M04 is usable in applications from 100 MHz to 10 GHz. The NE661M04 provides excellent low voltage/low current performance.

NEC's new low profile/flat lead style "M04" package is ideal for today's portable wireless applications. The NE661M04 is an ideal choice for LNA and oscillator requirements in all mobile communication systems.

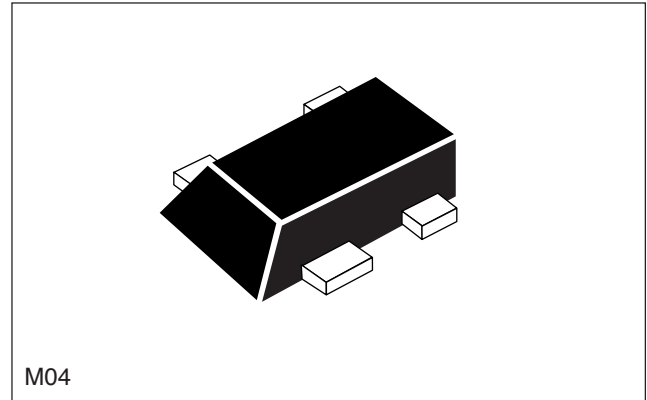

ELECTRICAL CHARACTERISTICS ($T_A = 25^\circ\text{C}$)

		PART NUMBER EIAJ ¹ REGISTERED NUMBER PACKAGE OUTLINE	NE661M04 2SC5507 M04			
SYMBOLS		PARAMETERS AND CONDITIONS	UNITS	MIN	TYP	MAX
DC	ICBO	Collector Cutoff Current at $V_{CE} = 5$ V, $I_E = 0$	μA			0.1
	IEBO	Emitter Cutoff Current at $V_{EB} = 1$ V, $I_C = 0$	μA			0.1
	hFE	Forward Current Gain ² at $V_{CE} = 2$ V, $I_C = 5$ mA		50	70	100
RF	f_T	Gain Bandwidth at $V_{CE} = 3$ V, $I_C = 10$ mA, $f = 2$ GHz	GHz	20	25	
	MSG	Maximum Stable Gain ⁴ at $V_{CE} = 2$ V, $I_C = 5$ mA, $f = 2$ GHz	dB		22	
	IS_{21EI}^2	Insertion Power Gain at $V_{CE} = 2$ V, $I_C = 5$ mA, $f = 2$ GHz	dB	14	17	
	NF	Noise Figure at $V_{CE} = 2$ V, $I_C = 2$ mA, $f = 2$ GHz, $Z_{IN} = Z_{OPT}$	dB		1.2	1.5
	P1dB	Output Power at 1 dB compression point at $V_{CE} = 2$ V, $I_C = 5$ mA, $f = 2$ GHz	dBm		5	
	IP ₃	Third Order Intercept Point at $V_{CE} = 2$ V, $I_C = 5$ mA, $f = 2$ GHz	dBm		15	
	Cre	Feedback Capacitance ³ at $V_{CB} = 2$ V, $I_C = 0$, $f = 1$ MHz	pF		0.08	0.12

Notes:

1. Electronic Industrial Association of Japan.
2. Pulsed measurement, pulse width ≤ 350 μs , duty cycle $\leq 2\%$.
3. Capacitance is measured by capacitance meter (automatic balance bridge method) when emitter pin is connected to the guard pin.

$$4. \text{MSG} = \left| \frac{S_{21}}{S_{12}} \right|$$

ABSOLUTE MAXIMUM RATINGS¹ (T_A = 25°C)

SYMBOLS	PARAMETERS	UNITS	RATINGS
V _{CB0}	Collector to Base Voltage	V	15
V _{CE0}	Collector to Emitter Voltage	V	3.3
V _{EB0}	Emitter to Base Voltage	V	1.5
I _c	Collector Current	mA	12
P _T	Total Power Dissipation	mW	39
T _J	Junction Temperature	°C	150
T _{STG}	Storage Temperature	°C	-65 to +150

Note:

1. Operation in excess of any one of these parameters may result in permanent damage.

THERMAL RESISTANCE

ITEM	SYMBOL	VALUE	UNIT
Junction to Case Resistance	R _{th j-c}	240	°C/W
Junction to Ambient Resistance	R _{th j-a}	650	°C/W

TYPICAL NOISE PARAMETERS (T_A = 25°C)

FREQ. (GHz)	NF _{OPT} (dB)	G _A (dB)	Γ _{OPT}		R _n /50
			MAG	ANG	
V _C = 1 V, I _C = 1 mA					
0.50	1.08	21.40	0.67	13	0.60
0.90	1.13	18.90	0.64	31	0.64
1.00	1.14	18.40	0.64	33	0.64
1.50	1.20	15.70	0.63	43	0.64
2.00	1.29	14.20	0.62	50	0.62
2.50	1.40	13.20	0.61	59	0.55
3.00	1.55	12.50	0.60	67	0.45
V _C = 2 V, I _C = 1 mA					
0.50	1.12	21.70	0.69	13	0.57
0.90	1.15	19.50	0.66	26	0.56
1.00	1.16	19.10	0.65	30	0.55
1.50	1.23	16.50	0.64	37	0.69
2.00	1.32	14.70	0.64	46	0.68
2.50	1.45	13.90	0.63	60	0.55
3.00	1.60	13.30	0.62	69	0.52
V _C = 2 V, I _C = 5 mA					
0.50	1.69	27.41	0.41	14	0.60
0.90	1.70	23.80	0.41	30	0.64
1.00	1.70	23.00	0.41	34	0.64
1.50	1.72	20.24	0.40	40	0.64
2.00	1.75	17.93	0.39	47	0.62
2.50	1.79	16.77	0.38	55	0.55
3.00	1.85	16.30	0.36	64	0.45

TYPICAL OPTIMAL NOISE MATCHING (T_A = 25°C)

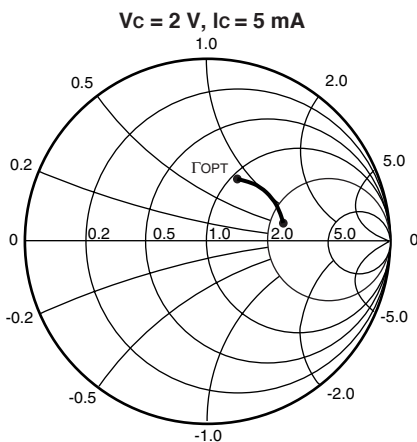
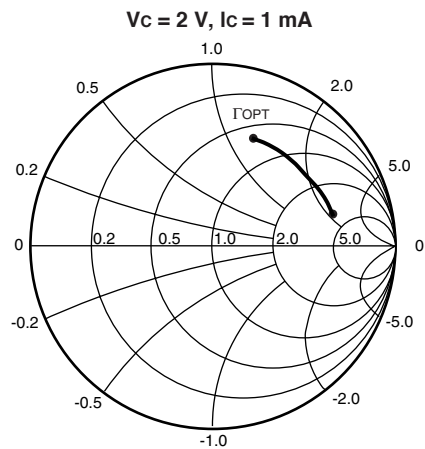
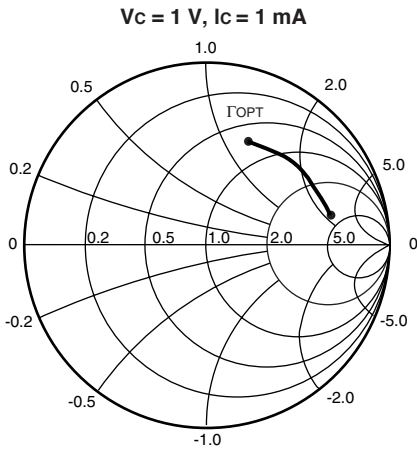

TYPICAL PERFORMANCE CURVES ($T_A = 25^\circ\text{C}$)

DC POWER DERATING CURVES

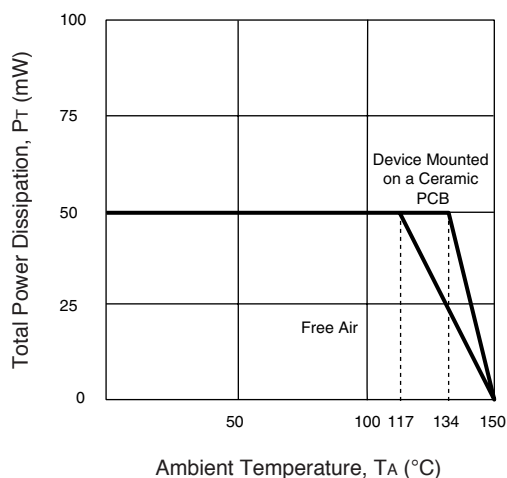

COLLECTOR CURRENT vs. DC BASE VOLTAGE

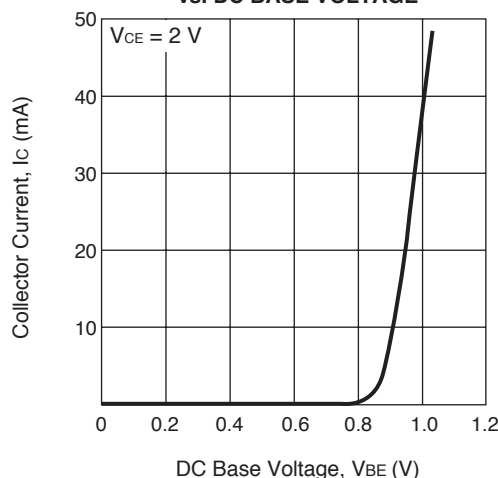

COLLECTOR CURRENT vs. COLLECTOR TO EMITTER VOLTAGE

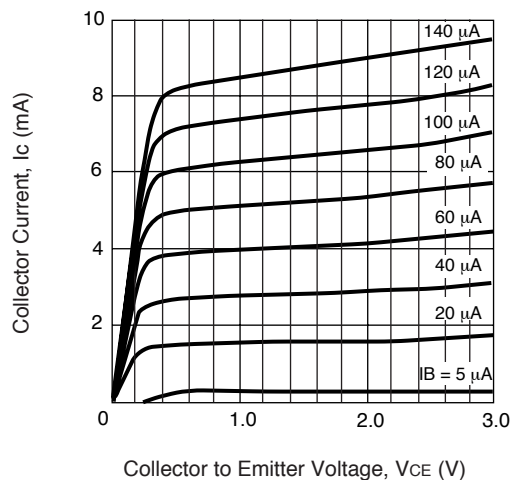

FORWARD CURRENT GAIN vs. COLLECTOR GAIN

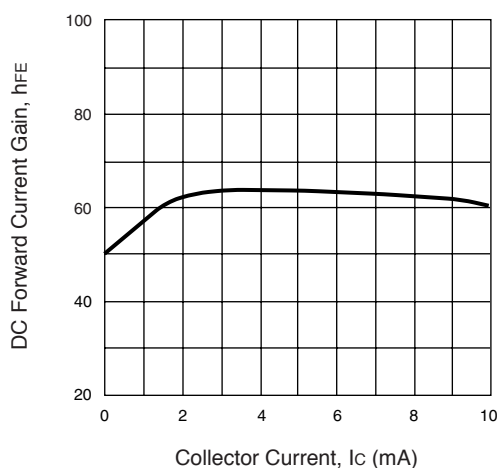

REVERSE TRANSFER CAPACITANCE vs. COLLECTOR BASE VOLTAGE

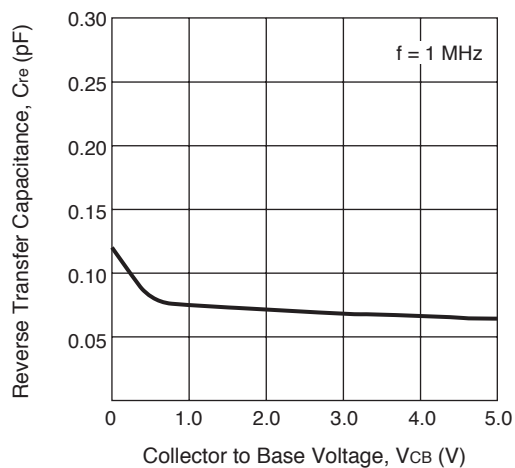

GAIN BANDWIDTH PRODUCT vs. COLLECTOR CURRENT

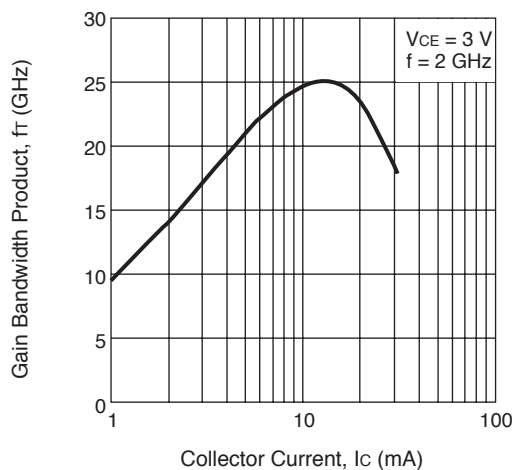

TYPICAL PERFORMANCE CURVES (T_A = 25°C)

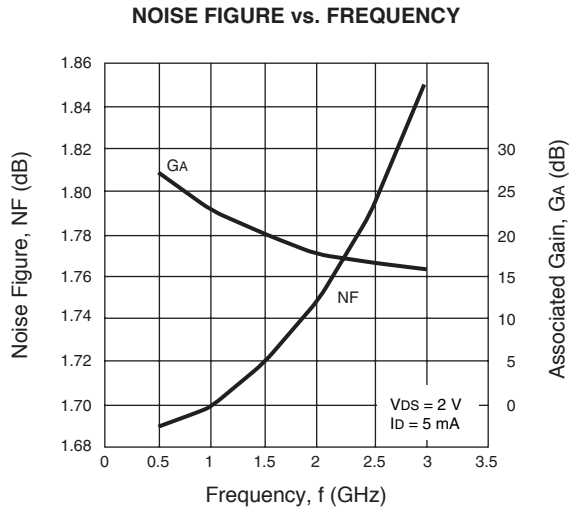
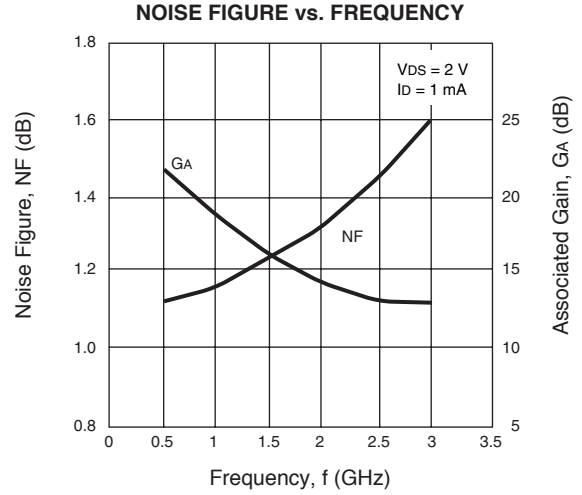
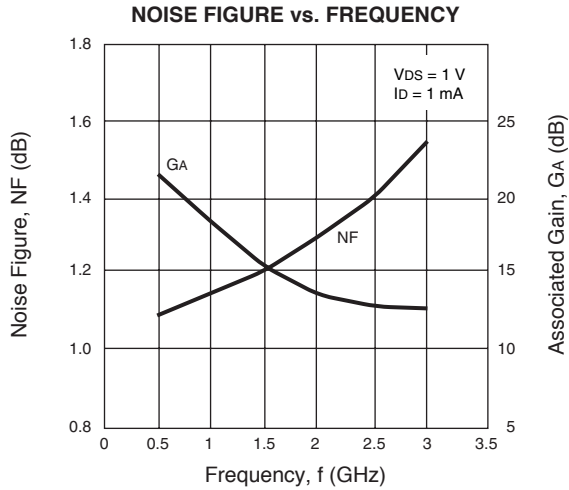

INSERTION POWER GAIN, MAXIMUM AVAILABLE POWER GAIN, MAXIMUM STABLE POWER GAIN vs. FREQUENCY

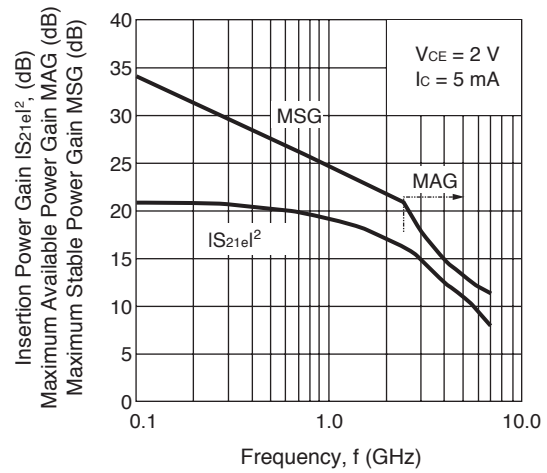

INSERTION POWER GAIN, MAXIMUM AVAILABLE POWER GAIN, MAXIMUM STABLE POWER GAIN vs. COLLECTOR CURRENT

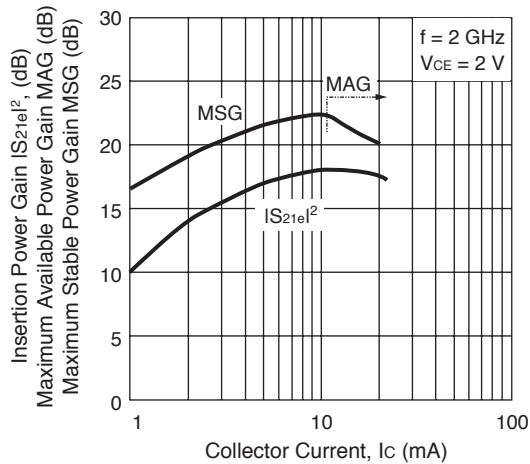

OUTPUT, COLLECTOR CURRENT vs. INPUT POWER

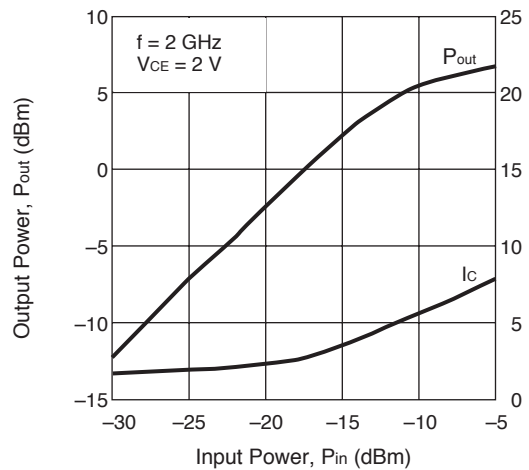

TYPICAL SCATTERING PARAMETERS (TA = 25°C)

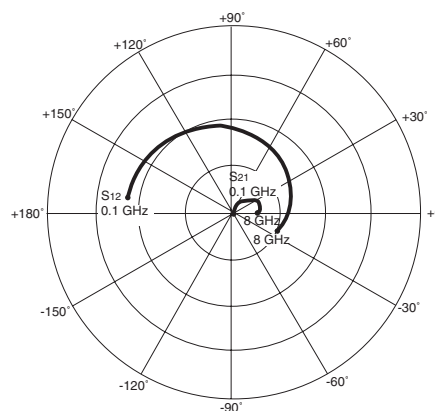
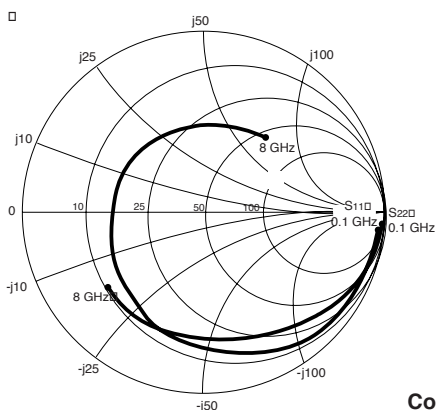

Coordinates in Ohms
Frequency in GHz
(VCE = 1 V, IC = 1 mA)

Vc = 1 V, Ic = 1 mA

FREQUENCY (GHz)	S11		S21		S12		S22		K	MAG ¹ (dB)
	MAG	ANG	MAG	ANG	MAG	ANG	MAG	ANG		
0.10	0.944	-4.3	2.912	172.0	0.005	84.9	0.991	-4.3	0.15	27.53
0.20	0.943	-8.0	2.868	171.3	0.009	77.9	0.970	-7.6	0.22	24.88
0.30	0.941	-11.9	2.845	168.3	0.013	75.1	0.955	-10.2	0.22	23.30
0.40	0.939	-15.4	2.837	164.2	0.017	73.0	0.943	-12.8	0.23	22.21
0.50	0.935	-19.2	2.845	160.7	0.021	70.8	0.935	-15.2	0.22	21.37
0.70	0.930	-26.7	2.807	153.5	0.028	66.3	0.922	-19.9	0.22	20.00
1.00	0.916	-37.4	2.734	144.1	0.038	59.6	0.906	-26.7	0.22	18.57
1.50	0.862	-55.4	2.614	126.2	0.051	46.5	0.850	-37.3	0.39	17.08
2.00	0.807	-72.7	2.526	110.8	0.061	36.2	0.821	-46.6	0.49	16.16
2.50	0.755	-89.4	2.337	96.3	0.068	26.8	0.794	-55.1	0.61	15.38
3.00	0.693	-106.9	2.236	82.4	0.071	18.3	0.768	-62.8	0.75	14.96
3.50	0.636	-124.7	2.095	68.9	0.072	10.7	0.744	-70.1	0.92	14.61
4.00	0.585	-143.5	1.977	55.6	0.071	4.5	0.723	-77.2	1.11	12.45
5.00	0.515	178.7	1.746	30.4	0.066	-2.9	0.696	-91.7	1.53	9.96
6.00	0.489	143.2	1.521	6.9	0.061	-1.9	0.689	-106.9	1.89	8.49
7.00	0.480	109.3	1.325	-14.4	0.066	0.9	0.688	-119.9	2.05	7.22
8.00	0.495	75.6	1.155	-34.5	0.076	2.0	0.679	-131.9	2.04	5.98

Note:

1. Gain Calculation:

$$MAG = \frac{|S_{21}|}{|S_{12}|} (K \pm \sqrt{K^2 - 1})$$

When $K \leq 1$, MAG is undefined and MSG values are used. $MSG = \frac{|S_{21}|}{|S_{12}|}$, $K = \frac{1 + |\Delta|^2 - |S_{11}|^2 - |S_{22}|^2}{2 |S_{12}| |S_{21}|}$, $\Delta = S_{11} S_{22} - S_{21} S_{12}$

MAG = Maximum Available Gain

MSG = Maximum Stable Gain

TYPICAL SCATTERING PARAMETERS (TA = 25°C)

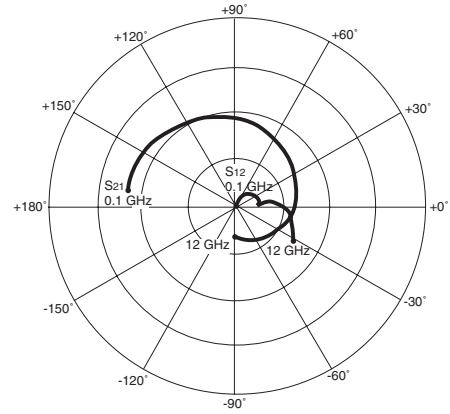
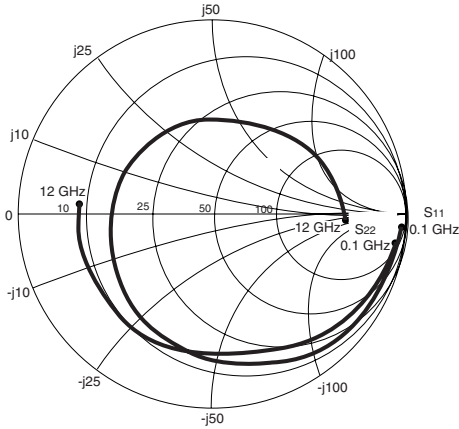

Coordinates in Ohms
Frequency in GHz
(V_{CE} = 2 V, I_c = 1 mA)

V_c = 2 V, I_c = 1 mA

FREQUENCY (GHz)	S ₁₁		S ₂₁		S ₁₂		S ₂₂		K	MAG ¹ (dB)
	MAG	ANG	MAG	ANG	MAG	ANG	MAG	ANG		
0.10	0.946	-4.2	2.929	172.1	0.005	84.2	0.992	-4.2	0.16	28.12
0.20	0.945	-7.7	2.882	171.5	0.008	76.7	0.971	-7.4	0.25	25.51
0.30	0.943	-11.6	2.860	168.6	0.012	74.8	0.956	-10.0	0.24	23.91
0.40	0.941	-14.9	2.853	164.6	0.015	72.6	0.944	-12.4	0.25	22.79
0.50	0.938	-18.6	2.861	161.2	0.018	70.6	0.937	-14.7	0.24	21.95
0.70	0.933	-25.9	2.825	154.2	0.025	66.5	0.924	-19.3	0.23	20.61
1.00	0.921	-36.3	2.756	145.0	0.033	60.4	0.909	-25.9	0.23	19.19
1.50	0.869	-53.9	2.643	127.4	0.045	47.8	0.856	-36.2	0.40	17.72
2.00	0.816	-70.7	2.563	112.3	0.053	38.1	0.829	-45.2	0.50	16.82
2.50	0.765	-87.0	2.377	98.0	0.059	29.2	0.805	-53.4	0.62	16.05
3.50	0.647	-121.6	2.142	70.9	0.063	14.4	0.759	-68.1	0.94	15.33
3.00	0.703	-104.1	2.281	84.2	0.062	9.4	0.781	-60.9	0.76	15.65
4.00	0.593	-139.9	2.027	57.7	0.062	9.4	0.740	-75.2	1.14	12.87
5.00	0.518	-177.4	1.799	32.7	0.057	4.6	0.716	-89.6	1.58	10.51
6.00	0.485	147.0	1.573	9.1	0.056	8.2	0.711	-104.7	1.86	9.10
7.00	0.472	112.6	1.372	-12.2	0.064	11.0	0.711	-117.7	1.89	7.86
8.00	0.483	78.3	1.197	-32.2	0.078	10.5	0.704	-129.7	1.82	6.62
9.00	0.541	49.9	1.039	-51.0	0.098	4.2	0.700	-142.3	1.56	5.85
10.00	0.604	28.4	0.914	-67.6	0.120	-3.8	0.697	-154.8	1.30	5.53
11.00	0.653	10.2	0.821	-84.2	0.144	-15.4	0.698	-169.7	1.07	5.90
12.00	0.691	-7.9	0.734	-101.2	0.168	-29.3	0.693	173.1	0.96	6.41

Note:

1. Gain Calculation:

$$MAG = \frac{|S_{21}|}{|S_{12}|} (K \pm \sqrt{K^2 - 1}). \text{ When } K \leq 1, \text{ MAG is undefined and MSG values are used. } MSG = \frac{|S_{21}|}{|S_{12}|}, K = \frac{1 + |\Delta|^2 - |S_{11}|^2 - |S_{22}|^2}{2 |S_{12}| |S_{21}|}, \Delta = S_{11} S_{22} - S_{21} S_{12}$$

MAG = Maximum Available Gain

MSG = Maximum Stable Gain

TYPICAL SCATTERING PARAMETERS (TA = 25°C)

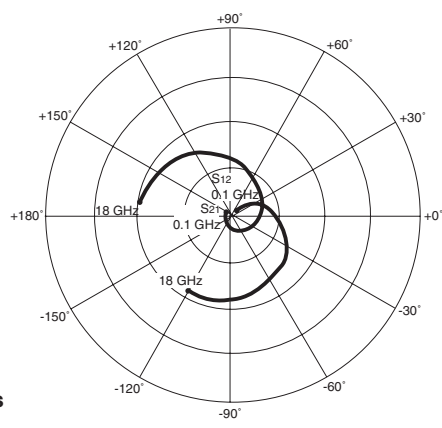
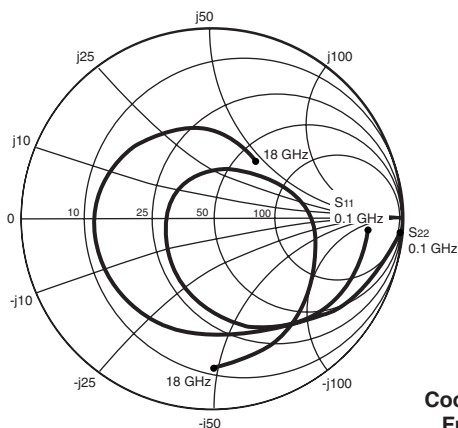

Coordinates in Ohms
Frequency in GHz
(VCE = 2 V, IC = 5 mA)

Vc = 2 V, Ic = 5 mA

FREQUENCY (GHz)	S11		S21		S12		S22		K	MAG ¹ (dB)
	MAG	ANG	MAG	ANG	MAG	ANG	MAG	ANG		
0.10	0.823	-5.3	10.113	172.3	0.004	81.5	0.979	-5.1	0.27	34.04
0.20	0.816	-11.4	9.907	167.9	0.008	75.6	0.954	-9.1	0.32	31.13
0.30	0.807	-17.0	9.734	163.0	0.011	72.1	0.933	-12.5	0.34	29.55
0.40	0.797	-22.0	9.571	158.1	0.014	70.1	0.916	-15.5	0.34	28.41
0.50	0.784	-27.2	9.433	153.3	0.017	67.9	0.902	-18.5	0.35	27.54
0.70	0.757	-37.1	9.037	144.0	0.022	63.3	0.873	-23.9	0.37	26.18
1.00	0.710	-51.0	8.386	131.4	0.029	57.0	0.836	-31.3	0.43	24.69
1.50	0.592	-71.5	7.208	111.1	0.036	47.3	0.748	-41.2	0.67	23.00
2.00	0.498	-89.6	6.429	95.0	0.042	41.5	0.704	-49.1	0.83	21.77
2.50	0.417	-106.7	5.446	80.7	0.046	37.6	0.672	-55.9	0.98	20.73
3.00	0.345	-124.2	4.809	67.8	0.050	34.7	0.649	-62.1	1.11	17.80
3.50	0.289	-143.0	4.283	55.9	0.054	32.2	0.631	-68.0	1.23	16.15
4.00	0.249	-163.9	3.862	44.7	0.058	30.0	0.619	-74.1	1.30	14.95
5.00	0.221	153.2	3.218	23.5	0.067	25.3	0.606	-87.3	1.37	13.17
6.00	0.235	117.2	2.732	3.3	0.078	19.5	0.614	-101.9	1.35	11.92
7.00	0.255	84.3	2.369	-15.7	0.090	11.9	0.621	-114.5	1.31	10.86
8.00	0.298	53.7	2.074	-33.9	0.101	3.5	0.622	-125.8	1.30	9.84
9.00	0.371	32.9	1.834	-51.5	0.114	-5.1	0.625	-138.3	1.20	9.31
10.00	0.439	18.4	1.657	-67.9	0.130	-13.2	0.624	-150.4	1.08	9.33
11.00	0.497	5.3	1.521	-85.1	0.149	-23.8	0.625	-165.1	0.93	10.10
12.00	0.547	-9.8	1.395	-103.4	0.167	-36.4	0.622	178.1	0.83	9.22
13.00	0.597	-26.5	1.269	-121.9	0.185	-50.4	0.606	162.0	0.76	8.37
14.00	0.648	-42.6	1.147	-140.2	0.193	-64.4	0.575	146.0	0.76	7.73
15.00	0.693	-53.5	1.041	-158.0	0.204	-77.1	0.522	127.4	0.77	7.08
16.00	0.732	-64.5	0.963	-176.4	0.221	-91.0	0.488	106.8	0.71	6.39
17.00	0.758	-77.4	0.864	163.2	0.230	-107.7	0.434	79.8	0.77	5.75
18.00	0.787	-89.6	0.756	144.0	0.230	-122.4	0.368	52.7	0.88	5.16

Note:

1. Gain Calculation:

$$MAG = \frac{|S_{21}|}{|S_{12}|} (K \pm \sqrt{K^2 - 1})$$

When $K \leq 1$, MAG is undefined and MSG values are used. $MSG = \frac{|S_{21}|}{|S_{12}|}$, $K = \frac{1 + |\Delta|^2 - |S_{11}|^2 - |S_{22}|^2}{2 |S_{12}| |S_{21}|}$, $\Delta = S_{11} S_{22} - S_{21} S_{12}$

MAG = Maximum Available Gain
MSG = Maximum Stable Gain

OUTLINE DIMENSIONS (Units in mm)

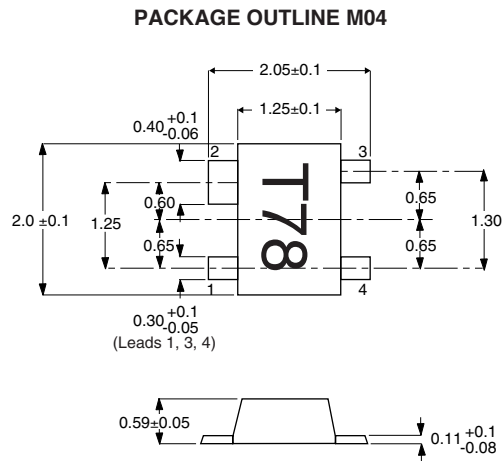

PIN CONNECTIONS

1. Emitter
2. Collector
3. Emitter
4. Base

ORDERING INFORMATION

PART NUMBER	QUANTITY	PACKAGING
NE661M04-T2-A	3000	Tape & Reel

NONLINEAR MODEL

SCHEMATIC

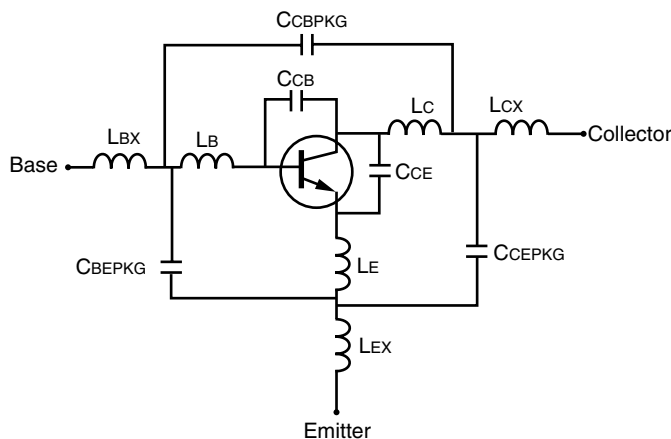

BJT NONLINEAR MODEL PARAMETERS ⁽¹⁾

Parameters	Q1	Parameters	Q1
IS	2.2e-18	MJC	0.33
BF	120	XCJC	1
NF	1	CJS	0
VAF	39.7	VJS	0.75
IKF	0.21	MJS	0
ISE	4.64e-14	FC	0.5
NE	2.09	TF	2e-12
BR	10	XTF	20
NR	1.004	VTF	10
VAR	1.9	ITF	0.1
IKR	0.1	PTF	200
ISC	1.1e-11	TR	1e-11
NC	41	EG	1.11
RE	3.5	XTB	0
RB	14	XTI	3
RBM	14	KF	0
IRB	0.004	AF	1
RC	8		
CJE	0.3e-12		
VJE	0.5		
MJE	0.33		
CJC	0.001e-12		
VJC	0.75		

(1) Gummel-Poon Model

ADDITIONAL PARAMETERS

Parameters	NE661M04
CCB	0.08e-12
CCE	0.1e-12
LB	0.93e-9
LC	0.6e-9
LE	0.2e-9
CCBPKG	0.001e-12
CCEPKG	0.25e-12
CBEPK	0.2e-12
LBX	0.2e-9
LCX	0.2e-9
LEX	0.05e-9

MODEL RANGE

Frequency: 0.1 to 18 GHz
 Bias: $V_{CE} = 0.5 \text{ V to } 2.5 \text{ V}$, $I_C = 1 \text{ mA to } 7 \text{ mA}$
 Date: 02/2002

Life Support Applications

These NEC products are not intended for use in life support devices, appliances, or systems where the malfunction of these products can reasonably be expected to result in personal injury. The customers of CEL using or selling these products for use in such applications do so at their own risk and agree to fully indemnify CEL for all damages resulting from such improper use or sale.

EXCLUSIVE NORTH AMERICAN AGENT FOR **NEC** RF, MICROWAVE & OPTOELECTRONIC SEMICONDUCTORS

CEL CALIFORNIA EASTERN LABORATORIES • Headquarters • 4590 Patrick Henry Drive • Santa Clara, CA 95054-1817 • (408) 988-3500 • Telex 34-6393 • FAX (408) 988-0279
 DATA SUBJECT TO CHANGE WITHOUT NOTICE

Internet: <http://WWW.CEL.COM>

01/03/2002

Subject: Compliance with EU Directives

CEL certifies, to its knowledge, that semiconductor and laser products detailed below are compliant with the requirements of European Union (EU) Directive 2002/95/EC Restriction on Use of Hazardous Substances in electrical and electronic equipment (RoHS) and the requirements of EU Directive 2003/11/EC Restriction on Penta and Octa BDE.

CEL Pb-free products have the same base part number with a suffix added. The suffix –A indicates that the device is Pb-free. The –AZ suffix is used to designate devices containing Pb which are exempted from the requirement of RoHS directive (*). In all cases the devices have Pb-free terminals. All devices with these suffixes meet the requirements of the RoHS directive.

This status is based on CEL’s understanding of the EU Directives and knowledge of the materials that go into its products as of the date of disclosure of this information.

Restricted Substance per RoHS	Concentration Limit per RoHS (values are not yet fixed)	Concentration contained in CEL devices	
		-A	-AZ
Lead (Pb)	< 1000 PPM	Not Detected	(*)
Mercury	< 1000 PPM	Not Detected	
Cadmium	< 100 PPM	Not Detected	
Hexavalent Chromium	< 1000 PPM	Not Detected	
PBB	< 1000 PPM	Not Detected	
PBDE	< 1000 PPM	Not Detected	

If you should have any additional questions regarding our devices and compliance to environmental standards, please do not hesitate to contact your local representative.

Important Information and Disclaimer: Information provided by CEL on its website or in other communications concerning the substance content of its products represents knowledge and belief as of the date that it is provided. CEL bases its knowledge and belief on information provided by third parties and makes no representation or warranty as to the accuracy of such information. Efforts are underway to better integrate information from third parties. CEL has taken and continues to take reasonable steps to provide representative and accurate information but may not have conducted destructive testing or chemical analysis on incoming materials and chemicals. CEL and CEL suppliers consider certain information to be proprietary, and thus CAS numbers and other limited information may not be available for release.

In no event shall CEL’s liability arising out of such information exceed the total purchase price of the CEL part(s) at issue sold by CEL to customer on an annual basis.

See CEL Terms and Conditions for additional clarification of warranties and liability.