

FEATURES

GENERAL

- 8,338,608 x 1 bit structure
- Single Power Supply Operation
 - 3.0 to 3.6 volt for read operations
- Latch-up protected to 100mA from -1V to Vcc +1V

PERFORMANCE

- High Performance
 - Fast access time: 20MHz serial clock (50pF + 1TTL Load)
- Low Power Consumption
 - Low active read current: 10mA (typical) at 20MHz
 - Low standby current: 30uA (CMOS)

SOFTWARE FEATURES

- Input Data Format
 - 1-byte Command code, 3-byte address, 1-byte byte address

HARDWARE FEATURES

- SCLK Input
 - Serial clock input
- SI Input
 - Serial Data Input
- SO Output
 - Serial Data Output
- PACKAGE
 - 28-pin SOP (330mil)

GENERAL DESCRIPTION

The MX23L8051 is a CMOS 8,338,608 bit serial Mask ROM, which is configured as 1,048,576 x 8 internally. The MX23L8051 features a serial peripheral interface and software protocol allowing operation on a simple 3-wire bus. The three bus signals are a clock input (SCLK), a serial data input (SI), and a serial data output (SO). Serial peripheral interface access to the device is enabled by \overline{CS} input.

The MX23L8051 provide sequential read operation on the whole chip.

When the device is not in operation and \overline{CS} is high, it is put in standby mode and draws less than 30uA DC current.

PIN CONFIGURATIONS

28-PIN SOP (330 mil)

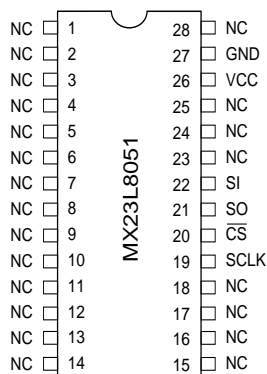

PIN DESCRIPTION

SYMBOL	DESCRIPTION
\overline{CS}	Chip Select
SI	Serial Data Input
SO	Serial Data Output
SCLK	Clock Input
VCC	+ 3.3V Power Supply
GND	Ground
NC	No Internal Connection

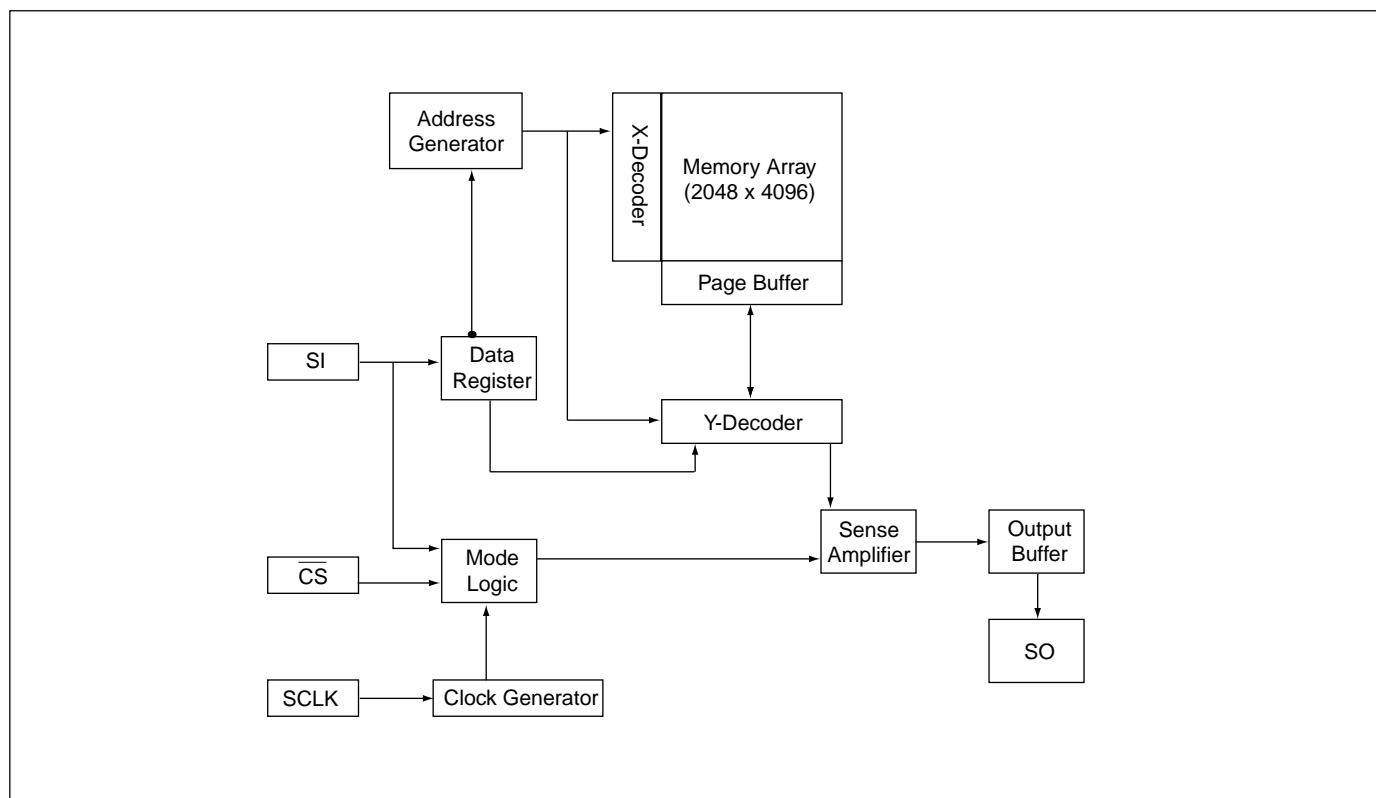
BLOCK DIAGRAM

COMMAND DEFINITION

Command	Read Array (byte)
1st	52H
2nd	AD1
3rd	AD2
4th	AD3
5th	BA
6th	X
7th	X
8th	X
9th	X
Action	n bytes read out until \overline{CS} goes high

Note:

- 1.X is dummy cycle and is necessary
- 2.AD1 to AD3 are address input data
- 3.BA is byte address

1-byte command code

	Bit7(MSB)	Bit6	Bit5	Bit4	Bit3	Bit2	Bit1	Bit0
3-byte address(0 to 0FFFH)								
AD1:	X	X	X	X	X	A19	A18	A17
AD2:	A16	A15	A14	A13	A12	A11	A10	A9
AD3:	X	X	X	X	X	X	A8	A7
1-byte byte address(0 to 7FH)								
BA:	X	A6	A5	A4	A3	A2	A1	A0

DEVICE OPERATION

1. When incorrect command is inputted to this LSI, this LSI becomes standby mode and keeps the standby mode until next \overline{CS} falling edge. In standby mode, SO pin of this LSI should be High-Z.
2. When correct command is inputted to this LSI, this LSI becomes active mode and keeps the active mode until next CSB rising edge.

COMMAND DESCRIPTION

(1) Read Array

This command is sent with the 4-byte address (command included), and the byte address, followed by four dummy bytes sent to give the device time to stabilize. The device will then send out data starting at the byte address until \overline{CS} goes high. The clock to clock out the data is supplied by the master serial peripheral interface.

(2) Standby Mode

When \overline{CS} is high and there is no operation in progress, the device is put in standby mode. Typical standby current is less than 30uA.

DATA SEQUENCE

Output data is serially sent out through SO pin, synchronized with the rising edge of SCLK, whereas input data is serially read in through SI pin, synchronized with the rising edge of SCLK. The bit sequence for both input and output data is bit 7 (MSB) first, then bit 6, bit 5, ..., and bit 0.(LSB)

ADDRESS SEQUENCE

The address assignment is described as follows :

BA: Byte address Bit sequence:	X	A6	A5	A4	A3	A2	A1	A0
AD1: First Address Bit sequence:	X	X	X	X	X	A19	A18	A17
AD2: Second Address Bit sequence:	A16	A15	A14	A13	A12	A11	A10	A9
AD3: Thrid Address Bit sequence:	X	X	X	X	X	X	A8	A7

ELECTRICAL SPECIFICATIONS
ABSOLUTE MAXIMUM RATINGS

RATING	VALUE
Ambient Operating Temperature	0° C to 70° C
Storage Temperature	-55° C to 125° C
Applied Input Voltage	-0.5V to 4.6V
Applied Output Voltage	-0.5V to 4.6V
VCC to Ground Potential	-0.5V to 4.6V

NOTICE:

1. Stresses greater than those listed under ABSOLUTE MAXIMUM RATINGS may cause permanent damage to the device. This is stress rating only and functional operational sections of this specification is not implied. Exposure to absolute maximum rating conditions for extended period may affect reliability.

2. Specifications contained within the following tables are subject to change.

3. During voltage transitions, all pins may overshoot to 4.6V or -0.5V for period up to 20ns.

4. All input and output pins may overshoot to VCC+0.5V while VCC+0.5V is smaller than or equal to 4.6V.

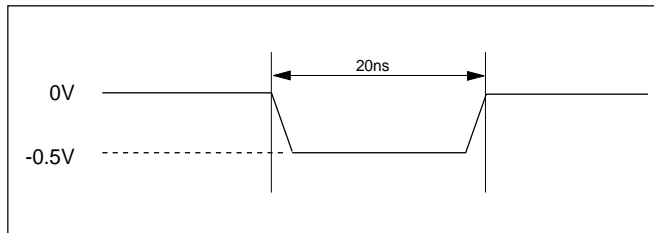
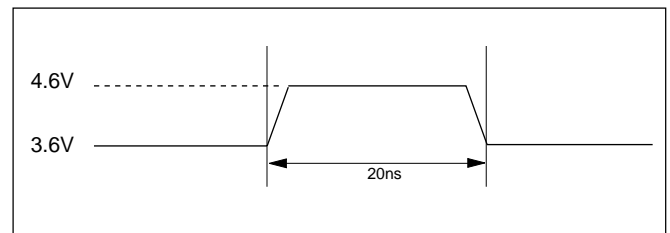
Maximum Negative Overshoot Waveform

Maximum Positive Overshoot Waveform

CAPACITANCE TA = 25° C, f = 1.0 MHz

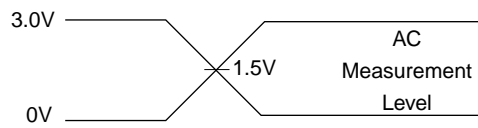
SYMBOL	PARAMETER	MIN.	TYP	MAX.	UNIT	CONDITIONS
CIN	Input Capacitance			10	pF	VIN = 0V
COUT	Output Capacitance			10	pF	VOUT = 0V

INPUT TEST WAVEFORMS AND MEASUREMENT LEVEL



Note: Input pulse rise and fall time are < 10ns

OUTPUT LOADING

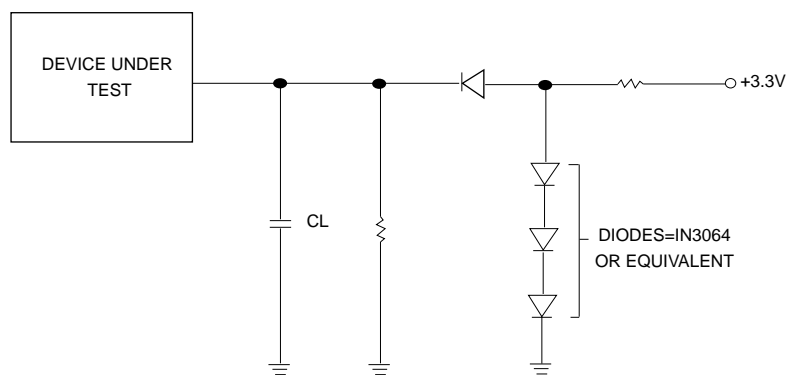

CL=50pF Including jig capacitance

DC CHARACTERISTICS (Temperature = 0° C to 70° C, VCC = 3.0V ~ 3.6V)

SYMBOL	PARAMETER	NOTES	MIN.	TYP	MAX.	UNITS	TEST CONDITIONS
IIL	Input Load Current	1			±10	uA	VCC = VCC Max VIN = VCC or GND
ILO	Output Leakage Current	1			±10	uA	VCC = VCC Max VIN = VCC or GND
ISB1	VCC Standby Current (CMOS)	1			30	uA	VCC = VCC Max $\overline{CS} = VCC \pm 0.2V$
ISB2	VCC Standby Current (TTL)			1	3	mA	VCC = VCC Max $\overline{CS} = VIH$
ICC1	VCC Read	1		10	30	mA	f=20MHz
VIL	Input Low Voltage		-0.5		0.8	V	
VIH	Input High Voltage		2.0		VCC+0.5	V	
VOL	Output Low Voltage				0.4	V	IOL = 500uA
VOH	Output High Voltage		2.4			V	IOH = -100uA

NOTES:

1. All currents are in RMS unless otherwise noted. Typical values at VCC = 3.3V, T = 25° C. These currents are valid for all product versions (package and speeds).
2. Typical value is calculated by simulation.

AC CHARACTERISTICS (Temperature = 0° C to 70° C, VCC = 3.0V ~ 3.6V)

SYMBOL	PARAMETER	Min.	Typ.	Max.	Units	Conditions
fSCLK	Clock Frequency			20	MHz	
tCYC	Clock Cycle Time	50			ns	
tSKH	Clock High Time	25			ns	
tSKL	Clock Low Time	25			ns	
tR	Clock Rise Time			6	ns	
tF	Clock Fall Time			6	ns	
tCSA	$\overline{\text{CS}}$ Lead Clock Time	50			ns	
tCSB	$\overline{\text{CS}}$ Lag Clock Time	50			ns	
tCSH	$\overline{\text{CS}}$ High Time	100			ns	
tDS	SI Setup Time	5			ns	
tDH	SI Hold Time	25			ns	
tAA	Access Time			30	ns	
tDOH	SO Hold Time	5			ns	
tDOZ	SO Floating Time	0		20	ns	

NOTES:

1. Typical value is calculated by simulation.

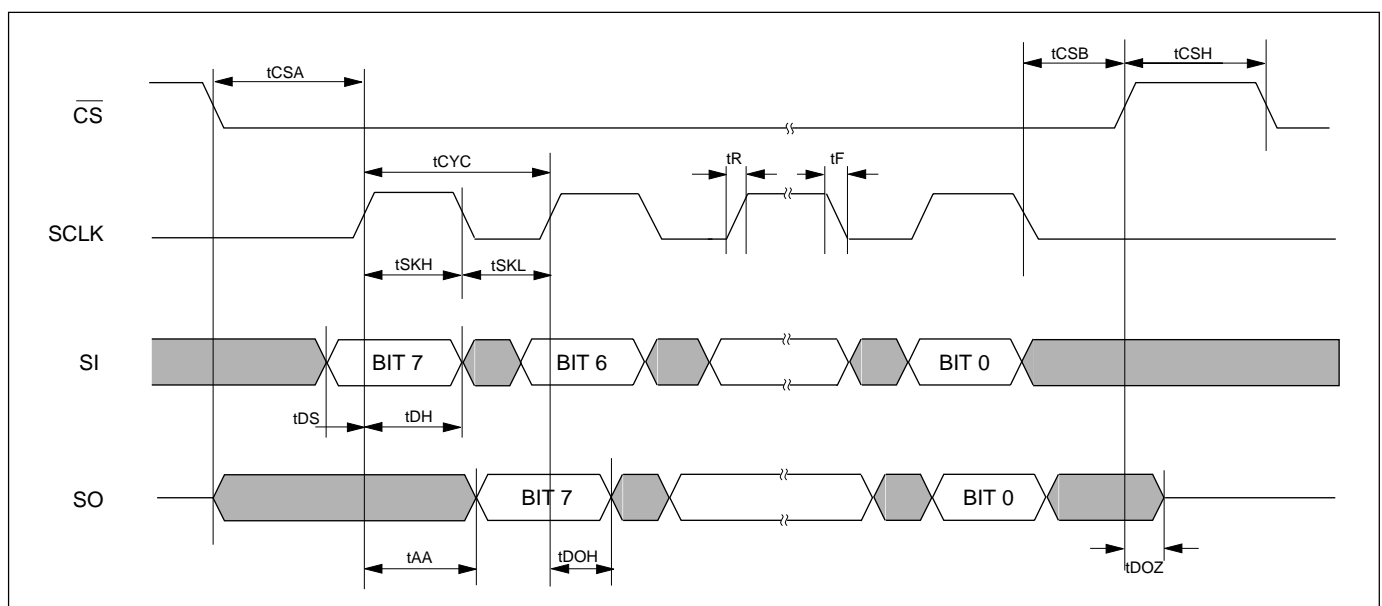
SERIAL DATA INPUT/OUTPUT TIMING

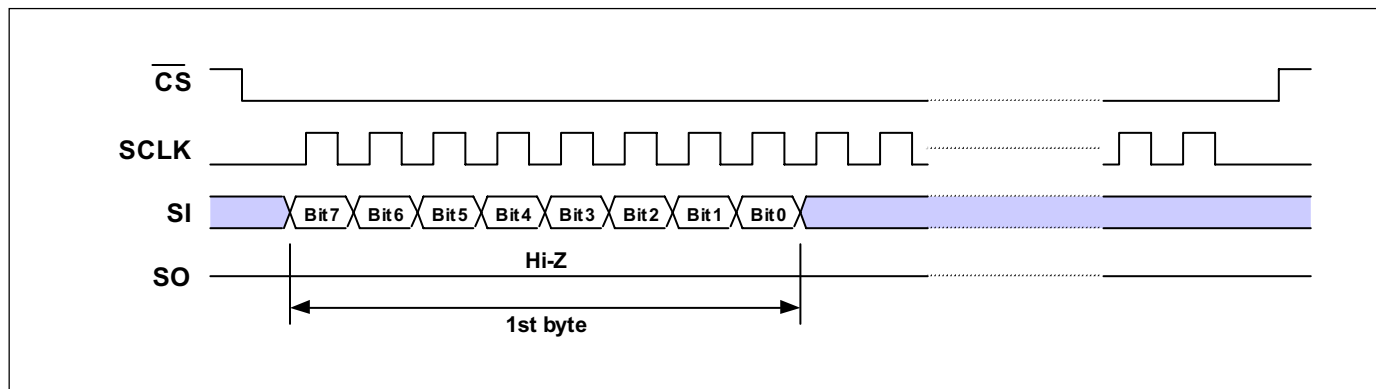
STANDBY TIMING WAVEFORM

When incorrect command is inputted to this LSI, this LSI becomes standby mode and keeps the standby mode until next \overline{CS} falling edge. In standby mode, SO pin of this LSI should be High-Z. While $\overline{CS}=V_{IH}$, current=standby current, while $\overline{CS}=V_{IL}$ and commands are issuing, or commands are invalid, current=5mA(typ.) to 15mA(max.).

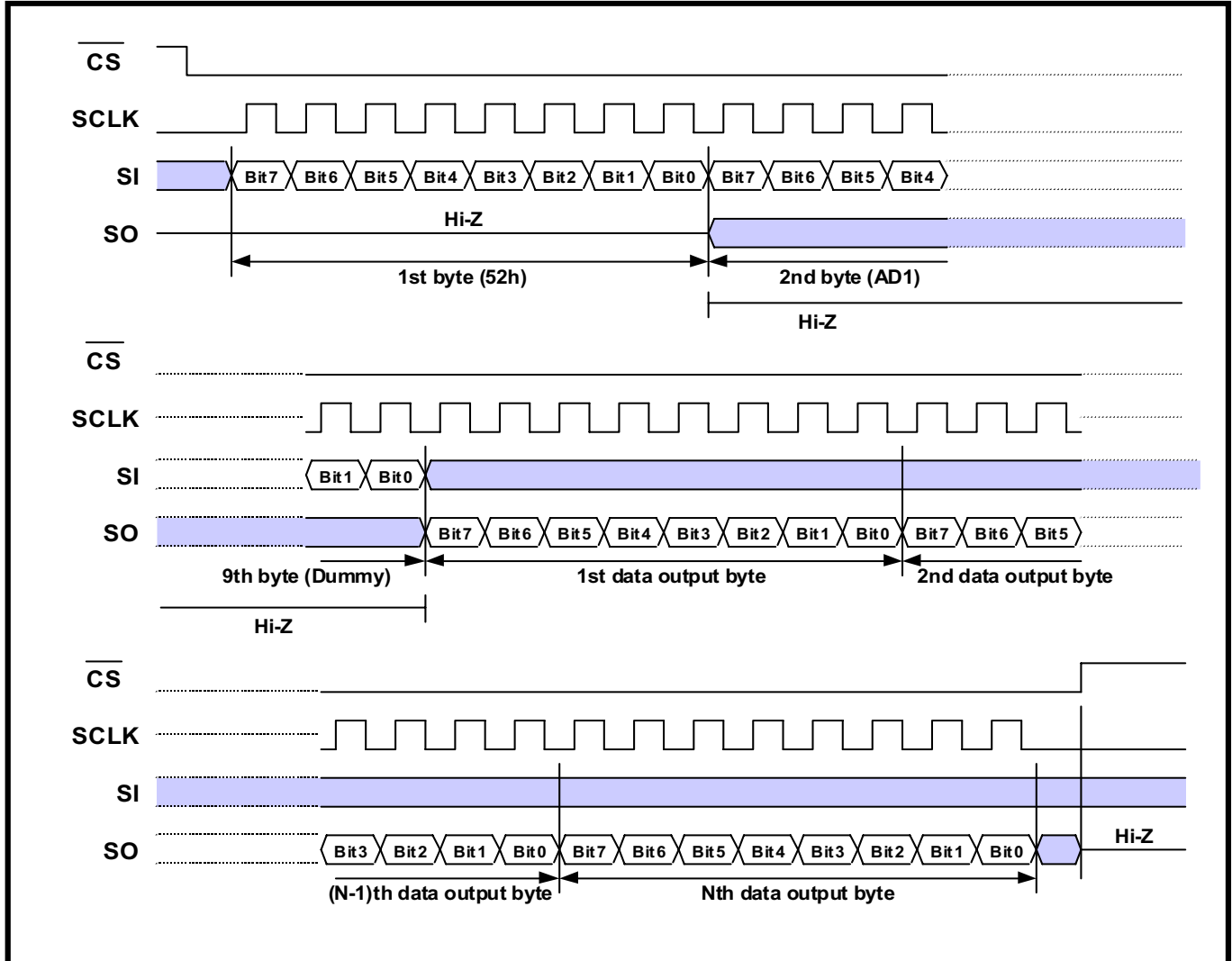
READ ARRAY TIMING WAVEFORM

NOTES:

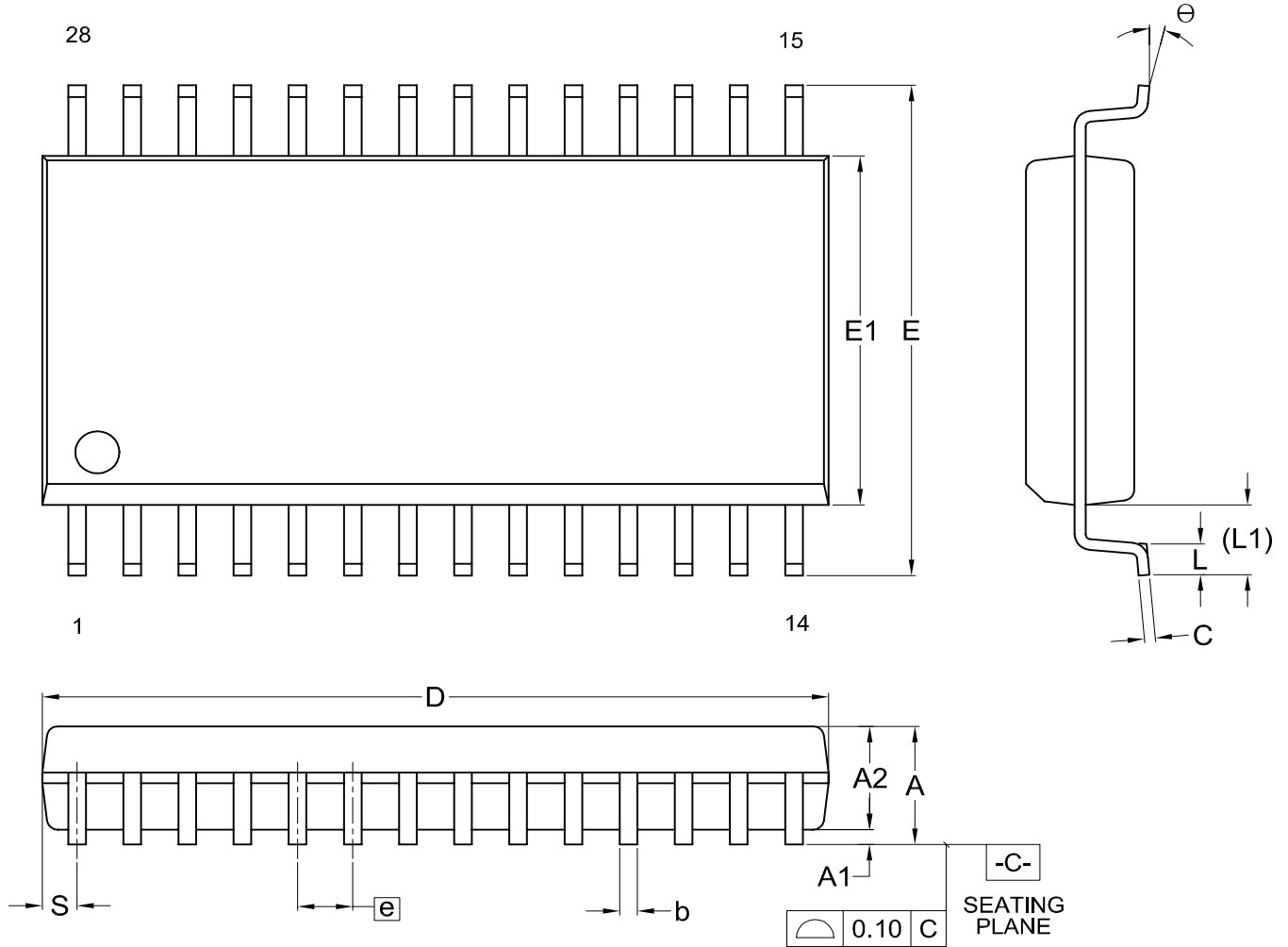
1. 1st Byte='52h'
2. 2nd Byte=Address 1(AD1), A17=BIT 0, A18=BIT1, A19=BIT2.
3. 3rd Byte=Address 2(AD2), A9=BIT0, A10=BIT1,.....A16=BIT7
4. 4th Byte=Address 3(AD3), A7=BIT0, A8=BIT1
5. 5th Byte=Byte Address(BA), A0=BIT0, A1=BIT1,.....A6=BIT6
6. 6th-9th Bytes for SI ==> Dummy Bytes (Don't care)
7. From Byte 10, SO Would Output Array Data

PACKAGE INFORMATION
Title: Package Outline for SOP 28L (330MIL)

Dimensions (inch dimensions are derived from the original mm dimensions)

SYMBOL		A	A1	A2	b	C	D	E	E1	e	L	L1	S	θ
UNIT														
mm	Min.	--	0.10	2.39	0.36	0.20	17.98	11.61	8.28		0.56	1.51	0.67	0
	Nom.	--	0.15	2.49	0.41	0.25	18.11	11.81	8.40	1.27	0.76	1.71	0.80	5
	Max.	2.84	0.25	2.59	0.51	0.30	18.24	12.02	8.53		0.96	1.91	0.92	8
Inch	Min.	--	0.004	0.094	0.014	0.008	0.708	0.457	0.326		0.022	0.059	0.026	0
	Nom.	--	0.006	0.098	0.016	0.010	0.713	0.465	0.331	0.050	0.030	0.067	0.031	5
	Max.	0.112	0.010	0.102	0.020	0.012	0.718	0.473	0.336		0.038	0.075	0.036	8

DWG.NO.	REVISION	REFERENCE			ISSUE DATE
		JEDEC	EIAJ		
6110-1403	8	MO-059			11-26-'03

REVISION HISTORY

Revision No.	Description	Page	Date
1.0	1. Low standby current: 8uA(typical) --> 30uA 2. From Advance Information to Formal Version	P1,4,7	AUG/26/2002
1.1	1. Modify Package Information	P11	JUN/23/2003



MX23L8051

MACRONIX INTERNATIONAL CO., LTD.

Headquarters:

TEL:+886-3-578-6688

FAX:+886-3-563-2888

Europe Office :

TEL:+32-2-456-8020

FAX:+32-2-456-8021

Hong Kong Office :

TEL:+86-755-834-335-79

FAX:+86-755-834-380-78

Japan Office :

Kawasaki Office :

TEL:+81-44-246-9100

FAX:+81-44-246-9105

Osaka Office :

TEL:+81-6-4807-5460

FAX:+81-6-4807-5461

Singapore Office :

TEL:+65-6346-5505

FAX:+65-6348-8096

Taipei Office :

TEL:+886-2-2509-3300

FAX:+886-2-2509-2200

MACRONIX AMERICA, INC.

TEL:+1-408-262-8887

FAX:+1-408-262-8810

<http://www.macronix.com>
