

OKI Semiconductor

MSC23432A-xxBS8/DS8

4,194,304-Word × 32-Bit DRAM MODULE : FAST PAGE MODE TYPE

DESCRIPTION

The OKI MSC23432A-xxBS8/DS8 is a fully decoded 4,194,304-word × 32-bit CMOS Dynamic Random Access Memory Module composed of eight 16-Mb DRAMs (4M × 4) in SOJ packages mounted with eight decoupling capacitors on a 72-pin glass epoxy single-inline package. This module is generally used for non-parity memory expansion applications such as fax machines, printers and personal computers.

FEATURES

- 4-Meg × 32-bit organization
- 72-Pin Socket Insertable Module
 - MSC23432A-xxBS8 : Gold tab
 - MSC23432A-xxDS8 : Solder tab
- Single 5 V supply ±10% tolerance
- Access times : 60, 70, 80 ns
- Input : TTL compatible
- Output : TTL compatible, 3-state
- Refresh : 2048 cycles/32 ms
- $\overline{\text{CAS}}$ before $\overline{\text{RAS}}$ refresh, $\overline{\text{CAS}}$ before $\overline{\text{RAS}}$ hidden refresh, $\overline{\text{RAS}}$ -only refresh capability
- Multi-bit test mode capability
- Fast Page Mode capability

PRODUCT FAMILY

Family	Access Time (Max.)			Cycle Time (Min.)	Power Dissipation	
	t _{RAC}	t _{AA}	t _{CAC}		Operating (Max.)	Standby (Max.)
MSC23432A-60BS8/DS8	60 ns	30 ns	15 ns	110 ns	5280 mW	44 mW (MOS level)
MSC23432A-70BS8/DS8	70 ns	35 ns	20 ns	130 ns	4840 mW	
MSC23432A-80BS8/DS8	80 ns	40 ns	20 ns	150 ns	4400 mW	

PIN CONFIGURATION

MSC23432A-xxBS8/DS8

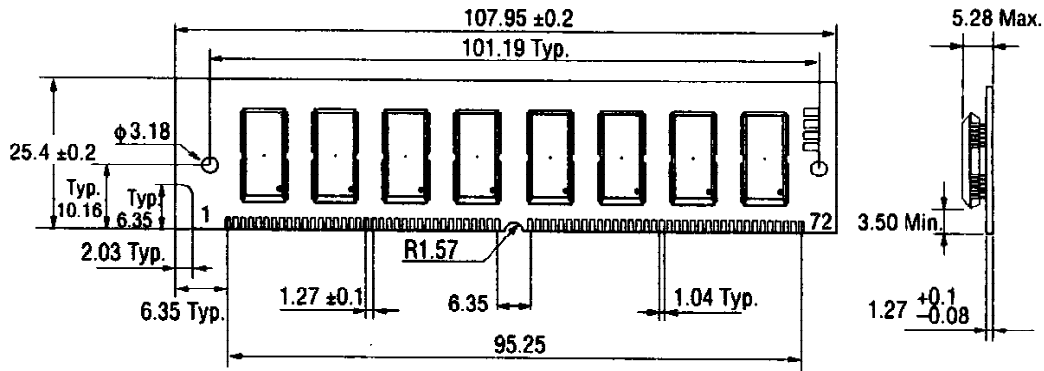

*1 The common size difference of the board width 12.5 mm of its height is specified as ±0.2. The value above 12.5 mm is specified as ±0.5.

Pin No.	Pin Name	Pin No.	Pin Name	Pin No.	Pin Name	Pin No.	Pin Name	Pin No.	Pin Name
1	V _{SS}	16	A4	31	A8	46	NC	61	DQ13
2	DQ0	17	A5	32	A9	47	WE	62	DQ30
3	DQ16	18	A6	33	NC	48	NC	63	DQ14
4	DQ1	19	A10	34	RAS2	49	DQ8	64	DQ31
5	DQ17	20	DQ4	35	NC	50	DQ24	65	DQ15
6	DQ2	21	DQ20	36	NC	51	DQ9	66	NC
7	DQ18	22	DQ5	37	NC	52	DQ25	67	PD1
8	DQ3	23	DQ21	38	NC	53	DQ10	68	PD2
9	DQ19	24	DQ6	39	V _{SS}	54	DQ26	69	PD3
10	V _{CC}	25	DQ22	40	CAS0	55	DQ11	70	PD4
11	NC	26	DQ7	41	CAS2	56	DQ27	71	NC
12	A0	27	DQ23	42	CAS3	57	DQ12	72	V _{SS}
13	A1	28	A7	43	CAS1	58	DQ28		
14	A2	29	NC	44	RAS0	59	V _{CC}		
15	A3	30	V _{CC}	45	NC	60	DQ29		

Presence Detect Pins

Pin No.	Pin Name	MSC23432A -60BS8/DS8	MSC23432A -70BS8/DS8	MSC23432A -80BS8/DS8
67	PD1	V _{SS}	V _{SS}	V _{SS}
68	PD2	NC	NC	NC
69	PD3	NC	V _{SS}	NC
70	PD4	NC	NC	V _{SS}

BLOCK DIAGRAM

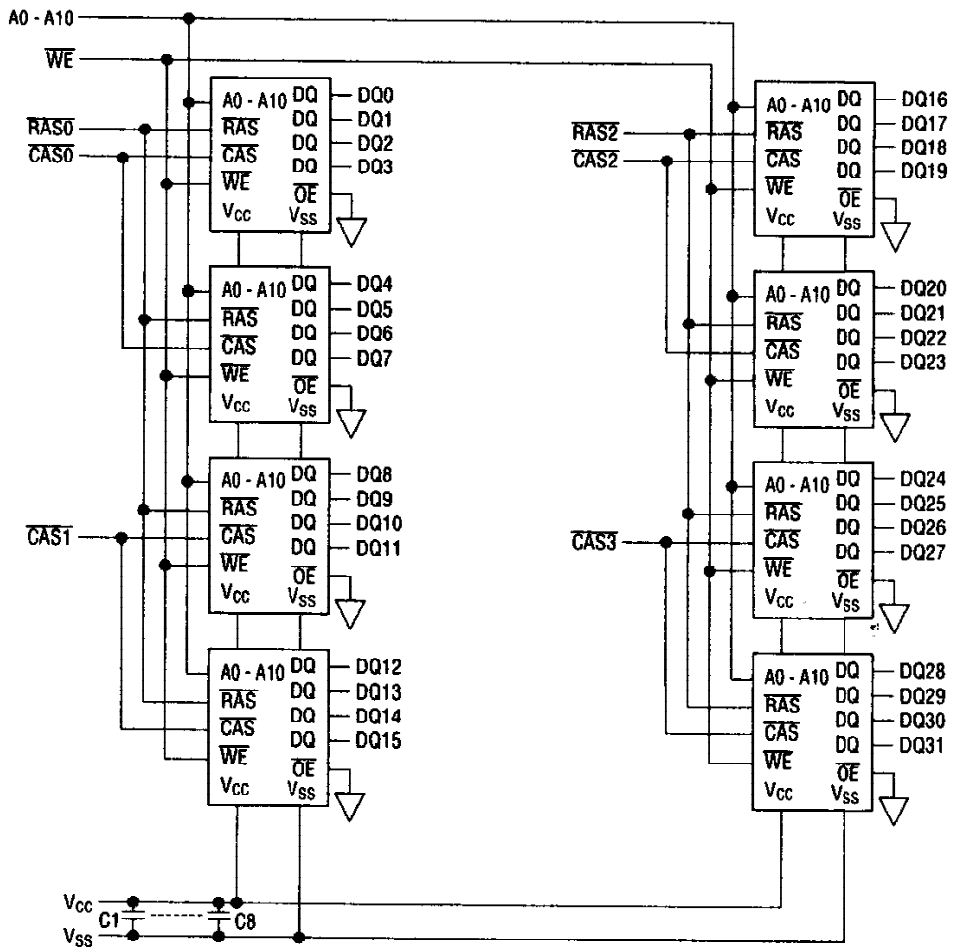

ELECTRICAL CHARACTERISTICS**Absolute Maximum Ratings**

Parameter	Symbol	Rating	Unit
Voltage on Any Pin Relative to V _{SS}	V _{IN} , V _{OUT}	-1.0 to 7.0	V
Voltage V _{CC} Supply Relative to V _{SS}	V _{CC}	-1.0 to 7.0	V
Short Circuit Output Current	I _{OS}	50	mA
Power Dissipation	P _D	8	W
Operating Temperature	T _{opr}	0 to 70	°C
Storage Temperature	T _{stg}	-40 to 125	°C

Note: Permanent device damage may occur if ABSOLUTE MAXIMUM RATINGS are exceeded. Functional operation should be restricted to the conditions as detailed in the operational sections of this data sheet. Exposure to absolute maximum rating conditions for extended periods may affect device reliability.

Recommended Operating Conditions(T_a = 0°C to 70°C)

Parameter	Symbol	Min.	Typ.	Max.	Unit
Power Supply Voltage	V _{CC}	4.5	5.0	5.5	V
	V _{SS}	0	0	0	V
Input High Voltage	V _{IH}	2.4	—	6.5	V
Input Low Voltage	V _{IL}	-1.0	—	0.8	V

Capacitance(T_a = 25°C, f = 1 MHz)

Parameter	Symbol	Typ.	Max.	Unit
Input Capacitance (A0 - A10)	C _{IN1}	—	57	pF
Input Capacitance (\overline{WE})	C _{IN2}	—	65	pF
Input Capacitance ($\overline{RAS0}$, $\overline{RAS2}$)	C _{IN3}	—	35	pF
Input Capacitance ($\overline{CAS0}$ - $\overline{CAS3}$)	C _{IN4}	—	20	pF
I/O Capacitance (DQ0 - DQ31)	C _{DQ}	—	16	pF

Note : Capacitance measured with Boonton Meter.

DC Characteristics

($V_{CC} = 5V \pm 10\%$, $T_a = 0^\circ C$ to $70^\circ C$)

Parameter	Symbol	Condition	MSC23432A -60BS8/DS8		MSC23432A -70BS8/DS8		MSC23432A -80BS8/DS8		Unit	Note
			Min.	Max.	Min.	Max.	Min.	Max.		
			Input Leakage Current	I_{LI}	$0V \leq V_i \leq 6.5V$; All other pins not under test = $0V$	-80	80	-80		
Output Leakage Current	I_{LO}	D_{OUT} disable $0V \leq V_O \leq 5.5V$	-10	10	-10	10	-10	10	μA	
Output High Voltage	V_{OH}	$I_{OH} = -5.0mA$	2.4	V_{CC}	2.4	V_{CC}	2.4	V_{CC}	V	
Output Low Voltage	V_{OL}	$I_{OL} = 4.2mA$	0	0.4	0	0.4	0	0.4	V	
Average Power Supply Current (Operating)	I_{CC1}	\overline{RAS} , \overline{CAS} cycling, $t_{RC} = \text{Min.}$	—	960	—	880	—	800	mA	1, 2
Power Supply Current (Standby)	I_{CC2}	\overline{RAS} , $\overline{CAS} = V_{IH}$	—	16	—	16	—	16	mA	1
		\overline{RAS} , \overline{CAS} $\geq V_{CC} - 0.2V$	—	8	—	8	—	8	mA	1
Average Power Supply Current (\overline{RAS} -only Refresh)	I_{CC3}	\overline{RAS} cycling, $\overline{CAS} = V_{IH}$, $t_{RC} = \text{Min.}$	—	960	—	880	—	800	mA	1, 2
Average Power Supply Current (\overline{CAS} before \overline{RAS} Refresh)	I_{CC6}	\overline{RAS} cycling, \overline{CAS} before \overline{RAS} , $t_{RC} = \text{Min.}$	—	960	—	880	—	800	mA	1, 2
Average Power Supply Current (Fast Page Mode)	I_{CC7}	$\overline{RAS} = V_{IL}$, \overline{CAS} cycling, $t_{PC} = \text{Min.}$	—	880	—	800	—	720	mA	1, 3

- Notes: 1. Specified values are obtained with the output open.
 2. Address can be changed once or less while $\overline{RAS} = V_{IL}$.
 3. Address can be changed once or less while $\overline{CAS} = V_{IH}$.

AC Characteristics (1/2)

(V_{CC} = 5 V ±10%, T_a = 0°C to 70°C) Note 1,2,3,9,10

Parameter	Symbol	MSC23432A -60BS8/DS8		MSC23432A -70BS8/DS8		MSC23432A -80BS8/DS8		Unit	Note
		Min.	Max.	Min.	Max.	Min.	Max.		
		Random Read or Write Cycle Time	t _{RC}	110	—	130	—		
Fast Page Mode Cycle Time	t _{PC}	40	—	45	—	50	—	ns	
Access Time from $\overline{\text{RAS}}$	t _{RAC}	—	60	—	70	—	80	ns	4, 5, 6
Access Time from $\overline{\text{CAS}}$	t _{CAC}	—	15	—	20	—	20	ns	4, 5
Access Time from Column Address	t _{AA}	—	30	—	35	—	40	ns	4, 6
Access Time from $\overline{\text{CAS}}$ Precharge	t _{CPA}	—	35	—	40	—	45	ns	4
Output Low Impedance Time from $\overline{\text{CAS}}$	t _{CLZ}	0	—	0	—	0	—	ns	4
Output Buffer Turn-off Delay Time	t _{OFF}	0	15	0	20	0	20	ns	7
Transition Time	t _T	3	50	3	50	3	50	ns	3
Refresh Period	t _{REF}	—	32	—	32	—	32	ms	
$\overline{\text{RAS}}$ Precharge Time	t _{RP}	40	—	50	—	60	—	ns	
$\overline{\text{RAS}}$ Pulse Width	t _{RAS}	60	10K	70	10K	80	10K	ns	
$\overline{\text{RAS}}$ Pulse Width (Fast Page Mode)	t _{RASP}	60	100K	70	100K	80	100K	ns	
$\overline{\text{RAS}}$ Hold Time	t _{RSH}	15	—	20	—	20	—	ns	
$\overline{\text{CAS}}$ Precharge Time	t _{CP}	10	—	10	—	10	—	ns	
$\overline{\text{CAS}}$ Pulse Width	t _{CAS}	15	10K	20	10K	20	10K	ns	
$\overline{\text{CAS}}$ Hold Time	t _{CSH}	60	—	70	—	80	—	ns	
$\overline{\text{CAS}}$ to $\overline{\text{RAS}}$ Precharge Time	t _{CRP}	10	—	10	—	10	—	ns	
$\overline{\text{RAS}}$ to $\overline{\text{CAS}}$ Delay Time	t _{RCD}	20	45	20	50	20	60	ns	5
$\overline{\text{RAS}}$ to Column Address Delay Time	t _{RAD}	15	30	15	35	15	40	ns	6
Row Address Set-up Time	t _{ASR}	0	—	0	—	0	—	ns	
Row Address Hold Time	t _{RAH}	10	—	10	—	15	—	ns	
Column Address Set-up Time	t _{ASC}	0	—	0	—	0	—	ns	
Column Address Hold Time	t _{CAH}	15	—	15	—	15	—	ns	
Column Address Hold Time from $\overline{\text{RAS}}$	t _{AR}	50	—	55	—	60	—	ns	
Column Address to $\overline{\text{RAS}}$ Lead Time	t _{RAL}	30	—	35	—	40	—	ns	

AC Characteristics (2/2)

(V_{CC} = 5 V ±10%, T_a = 0°C to 70°C) Note 1,2,3,9,10

Parameter	Symbol	MSC23432A -60BS8/DS8		MSC23432A -70BS8/DS8		MSC23432A -80BS8/DS8		Unit	Note
		Min.	Max.	Min.	Max.	Min.	Max.		
		Read Command Set-up Time	t _{RCS}	0	—	0	—		
Read Command Hold Time	t _{RCH}	0	—	0	—	0	—	ns	8
Read Command Hold Time referenced to $\overline{\text{RAS}}$	t _{RRH}	0	—	0	—	0	—	ns	8
Write Command Set-up Time	t _{WCS}	0	—	0	—	0	—	ns	
Write Command Hold Time	t _{WCH}	10	—	15	—	15	—	ns	
Write Command Hold Time from $\overline{\text{RAS}}$	t _{WCR}	45	—	55	—	60	—	ns	
Write Command Pulse Width	t _{WP}	10	—	10	—	10	—	ns	
Write Command to $\overline{\text{RAS}}$ Lead Time	t _{RWL}	15	—	20	—	20	—	ns	
Write Command to $\overline{\text{CAS}}$ Lead Time	t _{CWL}	15	—	20	—	20	—	ns	
Data-in Set-up Time	t _{DS}	0	—	0	—	0	—	ns	
Data-in Hold Time	t _{DH}	15	—	15	—	15	—	ns	
Data-in Hold Time from $\overline{\text{RAS}}$	t _{DHR}	50	—	55	—	60	—	ns	
$\overline{\text{CAS}}$ Active Delay Time from $\overline{\text{RAS}}$ Precharge	t _{RPC}	10	—	10	—	10	—	ns	
$\overline{\text{RAS}}$ to $\overline{\text{CAS}}$ Set-up Time ($\overline{\text{CAS}}$ before $\overline{\text{RAS}}$)	t _{CSR}	10	—	10	—	10	—	ns	
$\overline{\text{RAS}}$ to $\overline{\text{CAS}}$ Hold Time ($\overline{\text{CAS}}$ before $\overline{\text{RAS}}$)	t _{CHR}	20	—	20	—	20	—	ns	
$\overline{\text{CAS}}$ Precharge Time (Refresh Counter Test)	t _{CPT}	40	—	40	—	40	—	ns	
$\overline{\text{WE}}$ to $\overline{\text{RAS}}$ Precharge Time ($\overline{\text{CAS}}$ before $\overline{\text{RAS}}$)	t _{WRP}	10	—	10	—	10	—	ns	
$\overline{\text{WE}}$ Hold Time from $\overline{\text{RAS}}$ ($\overline{\text{CAS}}$ before $\overline{\text{RAS}}$)	t _{WRH}	10	—	10	—	10	—	ns	
$\overline{\text{RAS}}$ to $\overline{\text{WE}}$ Set-up Time (Test Mode)	t _{WTS}	10	—	10	—	10	—	ns	
$\overline{\text{RAS}}$ to $\overline{\text{WE}}$ Hold Time (Test Mode)	t _{WTH}	20	—	20	—	20	—	ns	

- Notes:
1. A start-up delay of 200 μ s is required after power-up followed by a minimum of eight initialization cycles ($\overline{\text{RAS}}$ -only refresh or $\overline{\text{CAS}}$ before $\overline{\text{RAS}}$ refresh) before proper device operation is achieved.
When using the internal refresh counter, a minimum of eight $\overline{\text{CAS}}$ before $\overline{\text{RAS}}$ initialization cycles is required.
 2. AC measurement assume $t_{\tau} = 5$ ns.
 3. V_{IH} (Min.) and V_{IL} (Max.) are reference levels for measuring input timing signals. Transition times are measured between V_{IH} and V_{IL} .
 4. Measured with a load circuit equivalent to 2 TTL loads and 100 pF.
 5. Operation within the t_{RCD} (Max.) limit ensures that t_{RAC} (Max.) can be met. t_{RCD} (Max.) is specified as a reference point only. If t_{RCD} is greater than the specified t_{RCD} (Max.) limit, access time is controlled by t_{CAC} .
 6. Operation within the t_{RAD} (Max.) limit ensures that t_{RAC} (Max.) can be met. t_{RAD} (Max.) is specified as a reference point only. If t_{RAD} is greater than the specified t_{RAD} (Max.) limit, access time is controlled by t_{AA} .
 7. t_{OFF} (Max.) defines the time at which the output achieves an open circuit condition and is not referenced to output voltage levels.
 8. t_{RCH} or t_{RRH} must be satisfied for a read cycle.
 9. The test mode is initiated by performing a $\overline{\text{WE}}$ and $\overline{\text{CAS}}$ before $\overline{\text{RAS}}$ refresh cycle. This mode is latched and remains in effect until the exit cycle is generated. The test mode specified in this data sheet is an 8-bit parallel test function. CA10, CA1 and CA0 are not used. In a read cycle, if all internal bits are equal, the DQ pin will indicate a high level. If any internal bits are not equal, the DQ pin will indicate a low level.
The test mode is cleared and the memory device returned to its normal operating state by performing a $\overline{\text{RAS}}$ -only refresh cycle or a $\overline{\text{CAS}}$ before $\overline{\text{RAS}}$ refresh cycle.
 10. In a test mode read cycle, the access time parameters are delayed by 5 ns. The test mode parameters are obtained by adding 5 ns to the normal read cycle values.

See ADDENDUM E for AC Timing Waveforms