

No-adjustment Sync Separator Monolithic IC MM1068

Outline

This IC is a no-adjustment sync IC designed for use in VCR, TV and other video equipment. A ceramic resonator is used in the oscillation circuit for stable operation.

Features

1. Sync separator with AFC
2. Ceramic resonator means no adjustment required
3. High precision due to use of PLL format
4. Ceramic resonator can be selected for use in either PAL or NTSC
5. Power supply voltage $V_{CC}=5V$

Package

SIP-10A (MM1068XS)

Applications

1. TV
2. VCR
3. Other video equipment

Block Diagram

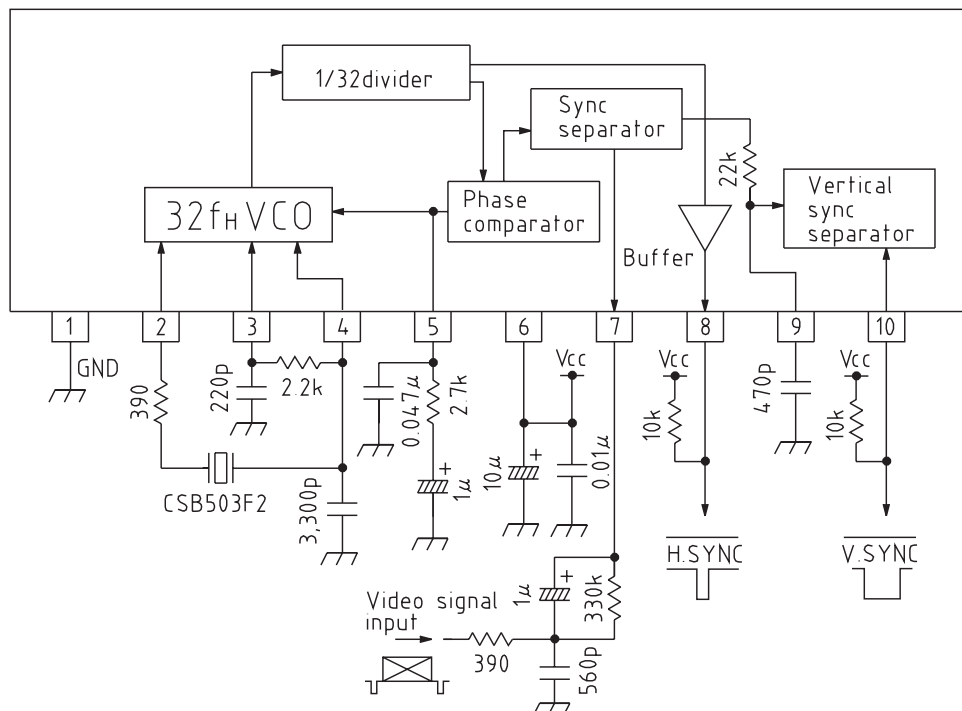

Pin Description

Pin no.	Pin name	Internal equivalent circuit diagram	Pin no.	Pin name	Internal equivalent circuit diagram
1	GND		6	V _{CC}	
2	OSC OUT		7	VIDEO IN	
3	OSC IN1		8	H.SYNC	
4	OSC IN2		9	V.INT	
5	LPF		10	V.SYNC	

Absolute Maximum Ratings (Ta=25°C)

Item	Symbol	Ratings	Units
Storage temperature	T _{STG}	-40~+125	°C
Operating temperature	T _{OPR}	-20~+75	°C
Power supply voltage	V _{CC} max.	7	V
Allowable loss	P _d	500	mW

Electrical Characteristics

(Except where noted otherwise, Ta=25°C, VCC=5.0V, X=CSB503F2, R=390 [OHM], C=3300pF, SW1=ON, SW2=OFF)

Item	Symbol	Measurement circuit	Measurement conditions	Min.	Typ.	Max.	Units
Operating power supply voltage	VCC	VCC		4.7	5.0	5.3	V
Consumption current	Id	Id			8.0	11.5	mA
Free-running frequency NTSC	fo1	TP1		15.534	15.734	15.934	kHz
Horizontal sync signal acquisition range NTSC	fCAP1	TP1	VIN : signal 1 *1 *2	300	500		Hz
Free-running frequency PAL	fo2	TP1	X=CSB500F40, R=200OHM, C=4700pF	15.425	15.625	15.825	kHz
Horizontal sync signal acquisition range PAL	fCAP2	TP1	X=CSB500F40, R=200OHM, C=4700pF, VIN : signal 1 *1 *3	300	500		Hz
LPF pin DC level	VLPF	TP4	SW2 : ON	0.9	1.4	1.9	V
Sync separation level	VSEPA	VIN	SW1 : OFF, VIN : staircase wave 1VP-P *4	20	50	80	mV
H. sync pulse width	tw1	TP1	VIN : signal 1, 15.734kHz *5	3.9	4.2	4.5	uS
H. sync delay time	Td1	TP1	VIN : signal 1, 15.734kHz *5	0.7	1.2	1.7	uS
H. sync output voltage L	VL1	TP1	VIN : signal 1, 15.734kHz *5		0.2	0.4	V
H. sync output voltage H	VH1	TP1	VIN : signal 1, 15.734kHz *5	4.8	5.0		V
V. sync pulse width	tw3	TP3	VIN : staircase wave 1VP-P *6	150	190	230	uS
V. sync delay time	td3	TP3	VIN : staircase wave 1VP-P *6	8.0	10.0	12.0	uS
V. sync output voltage L	VL3	TP3	VIN : staircase wave 1VP-P *6		0.2	0.4	V
V. sync output voltage H	VH3	TP3	VIN : staircase wave 1VP-P *6	4.8	5.0		V
V. sync switching voltage L	VTHL3	TP2	TP2 : DC voltage 5V → Low *7	1.5	1.8	2.1	V
V. sync switching voltage H	VTHH3	TP2	TP2 : DC voltage 0V → High *7	2.3	2.6	2.9	V

Notes:

*1 Signal 1 : Pulse signal with 0.3V amplitude and pulse width 4.7μS

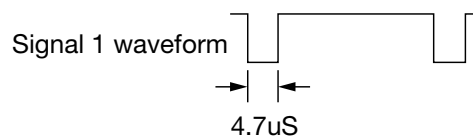

*2 Measuring horizontal sync signal pull-in range for NTSC

With TP1 waveform not synchronized to signal 1, adjust signal 1 frequency toward 15.734kHz. The measurement value is the smaller of the synchronized frequency and the difference from 15.734.

*3 Measuring horizontal sync signal pull-in range for PAL

With TP1 waveform not synchronized to signal 1, adjust signal 1 frequency toward 15.625kHz. The measurement value is the smaller of the synchronized frequency and the difference from 15.625.

*4 Measuring sync separation level

Gradually lower staircase wave signal sync tip level, and measure sync tip level when Pin 9 waveform starts to change.

*5 H. SYNC measurement

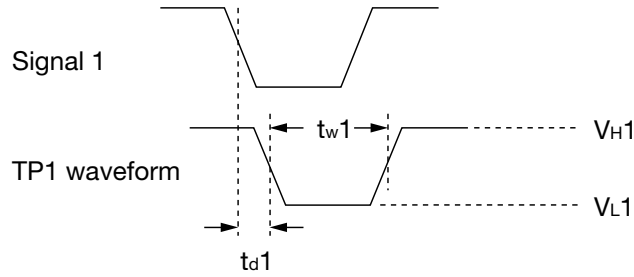

*6 V. SYNC measurement

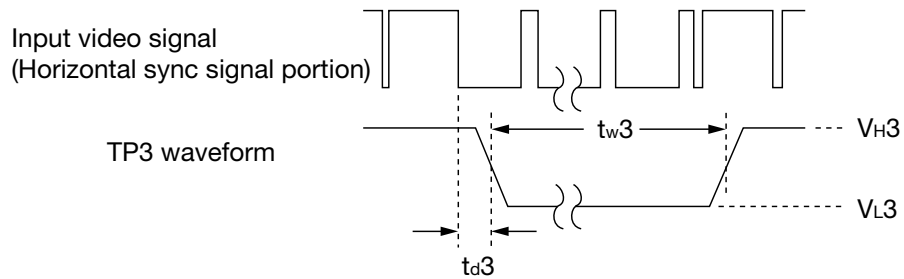

*7 V. SYNC switching voltage measurement

Gradually change the DC voltage impressed on TP2, and measure TP2 voltage when TP3 output switches.

Measuring Circuit

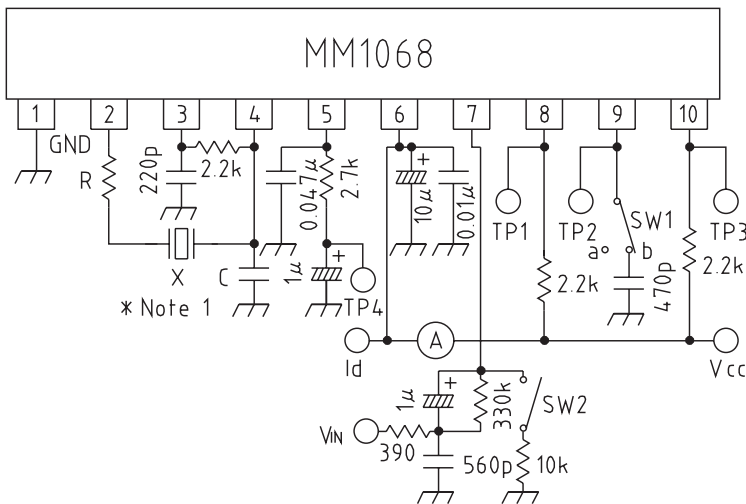

Note : *1

	NTSC	PAL
X	CSB503F2	CSB500F40
R	390Ω	220Ω
C	3300pF	4700pF

Application Circuits

There is a momentary phase lag in the H. SYNC output vertical feedback interval. When using this IC for OSD timing, characters at the top of the screen may bend due to IC deviation. If this happens, change the resistance between Pins 13 and 14 as shown, and the bending will improve by several H from the top edge of the screen.

Application Circuit 1

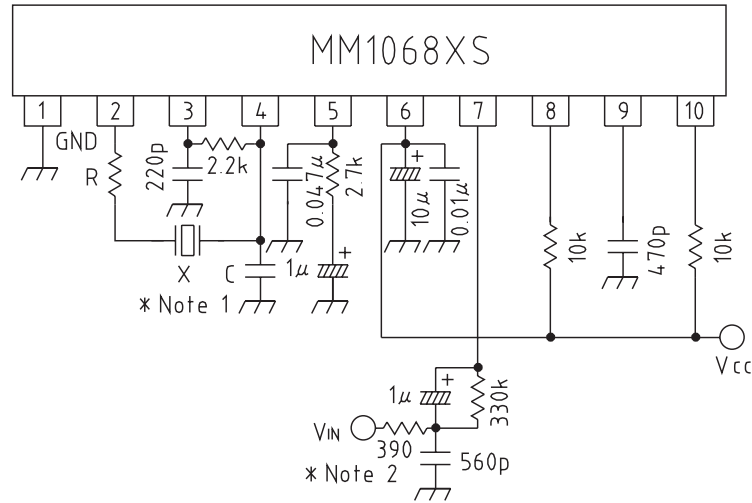

Application Circuit 2

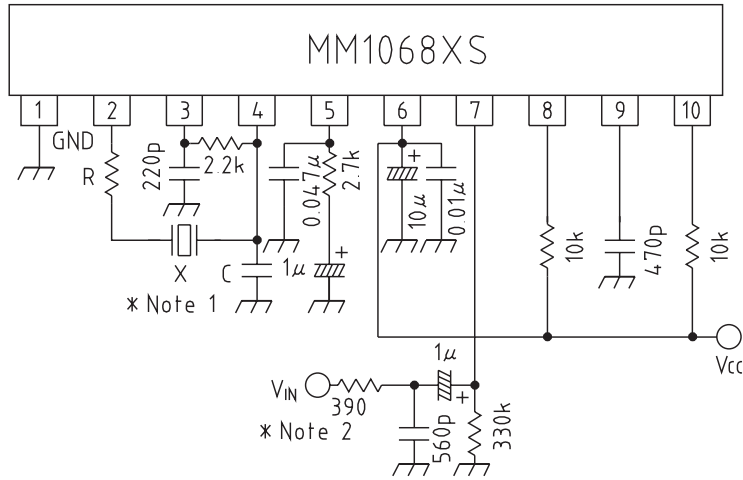

Note 1 : 1. *1

	NTSC	PAL
X	CSB503F2	CSB500F40
R1	1.5kΩ	1.8kΩ
R2	390Ω	
C1	220pF	
C2	3300pF	

- Resistors R1 and R2 should have precision of $\pm 1\%$.
- Capacitors C1 and C2 should have precision of $\pm 5\%$ and temperature characteristic of CH class.

Note 2 :

- *2 Input signal sync tip must be less than 1V for application circuit 1 Pin 7 external circuit.
- The above 1. does not apply for application circuit 2 Pin 7 external circuit. Pin 1 is clamped at approximately 2.5V.