

### Features

- (1) Wide band: High attenuation.  
Band wide: 150kHz ~ 30MHz, 2 stage filter
- (2) Fast-on Terminals
- (3) Compact, thin type package  
Low profile metal case  
10A type: 26mm

### Safety standard

- UL1283, CSA Std. C22. 2 No. 8 (C-UL)
- VDE0565 Teil. 3
- EN133200
- (VDE0565 will expire on July 23, 2003.)

### Specifications

Item	Model	MF1206	MF1210	MF1216
1	Rated voltage (AC, DC)	250V		
2	Rated current (AC, DC) (Note)	6A	10A	16A
3	Test voltage (terminal to case, AC 1 minute)	2500V (20mA) at 25°C, 70% RH		
4	Isolation resistance (terminal to case, 500VDC)	100MΩ min. at 25°C, 70% RH		
5	Leakage current	125V, 60Hz	0.5mA max.	
		250V, 60Hz	1mA max.	
6	DC resistance	140mΩ max.	50mΩ max.	34mΩ max.
7	Temperature rise	40°C max.		
8	Operating temperature	-25 ~ +85°C		
9	Operating humidity	30% ~ 95% RH (No dewdrop)		
10	Storage temperature	-40 ~ +85°C		
11	Storage humidity	10% ~ 95% RH (No dewdrop)		
12	Vibration	Sweep: 10 ~ 55 ~ 10 Hz (for one minute), Amplitude: 1,5 mm X, Y and Z axes for 2 hours		
13	Safety standard	Approved by UL1283, CSA C22.2 No. 8 (C-UL), VDE0565 Teil 3 and EN133200 (VDE).		
14	Weight (typ)	190g	220g	310g

(Note) : Value at Ta ≤ 35°C. Refer to the derating curve shown below at Ta > 35°C.

### Circuit

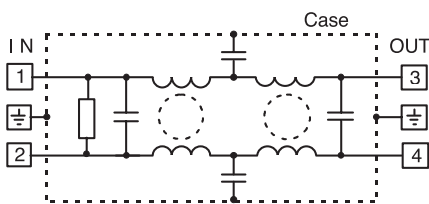

### Derating

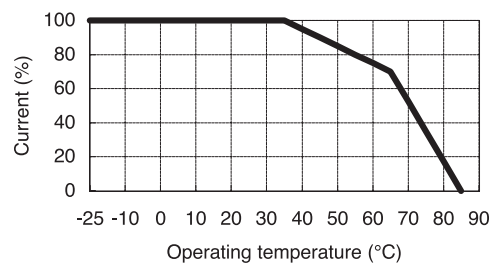

- Request customer specification for further details of specifications, outline, characteristics, etc.  
Read the instruction manual before usage.
- Contact us about delivery before ordering.

# MF-SERIES

## MF1206

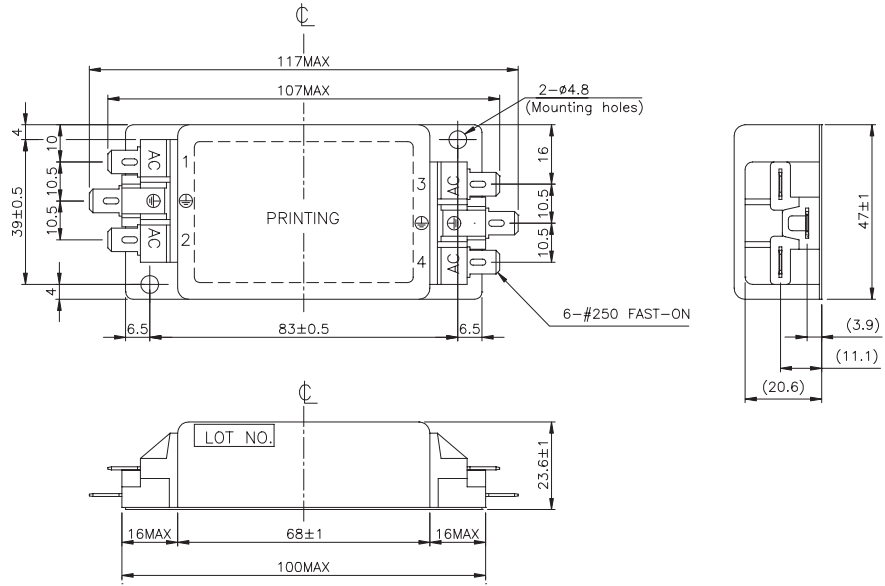

Case: Metal  
(Unit: mm)

## MF1210

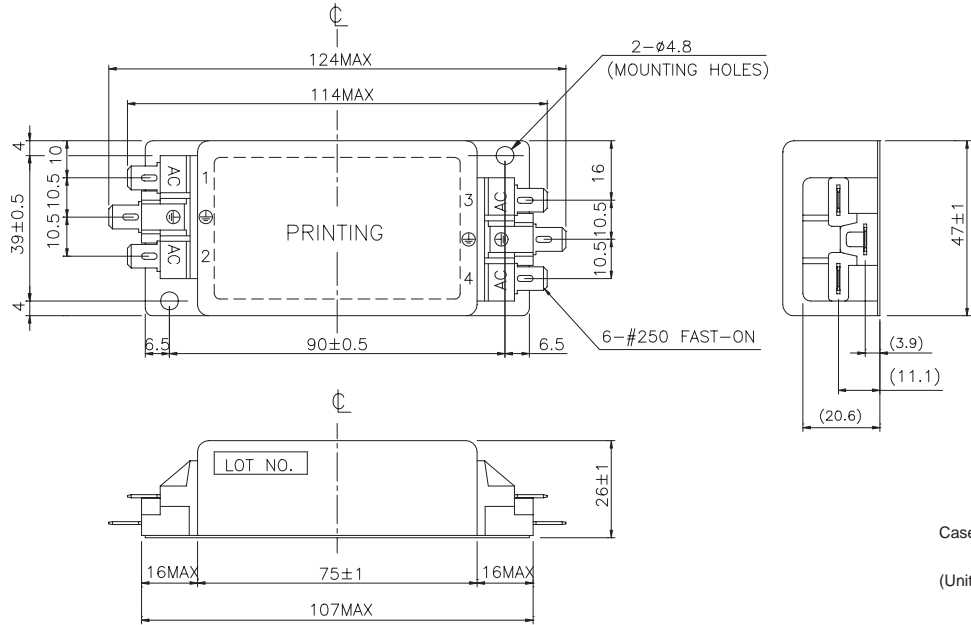

Case: Metal  
(Unit: mm)

## MF1216

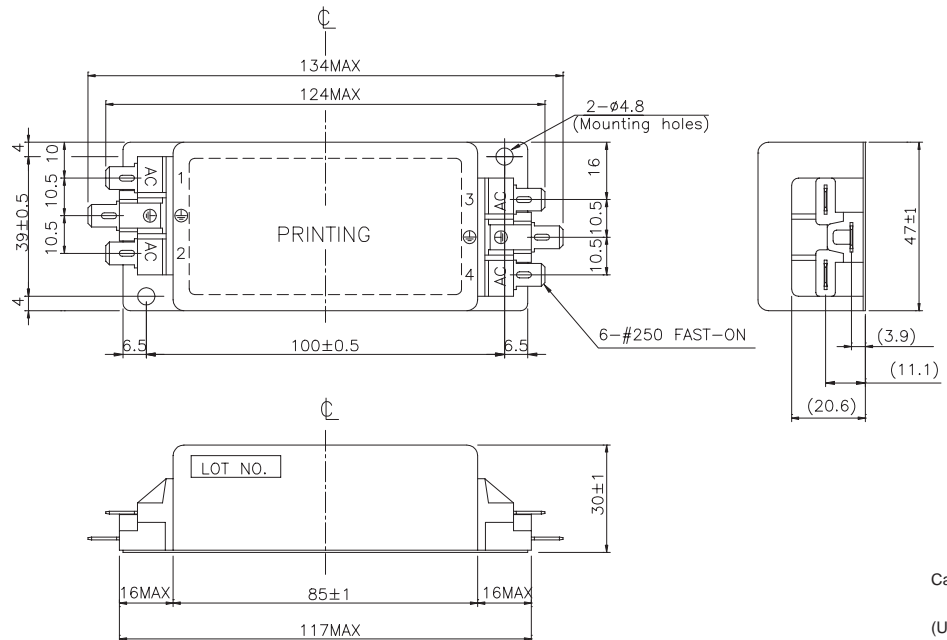

Case: Metal  
(Unit: mm)

## CHARACTERISTICS

### ■ Typical Insertion Loss

(1) Asymmetrical

(2) Symmetrical

#### MF1206

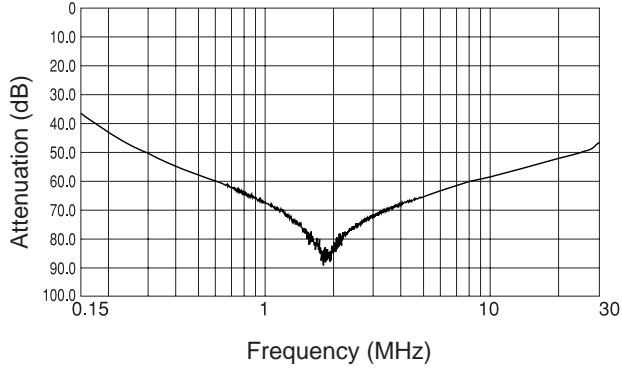

#### MF1206

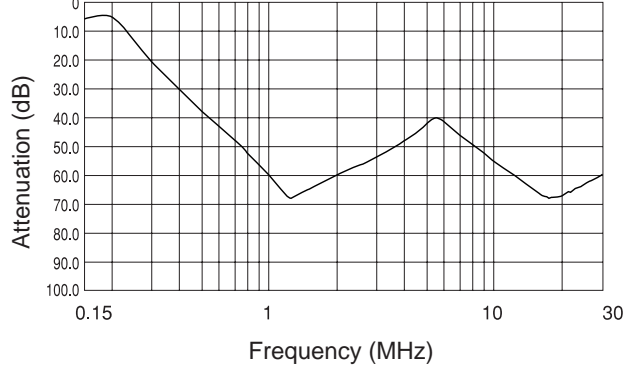

#### MF1210

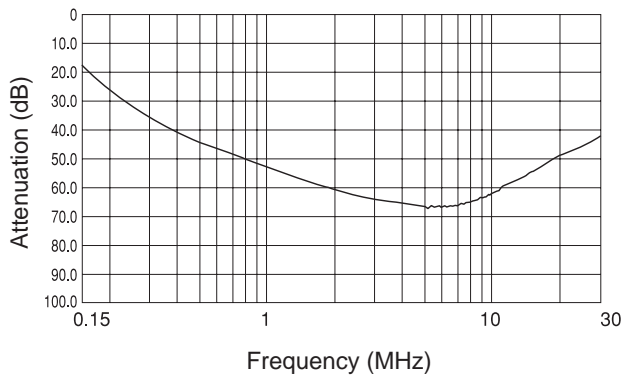

#### MF1210

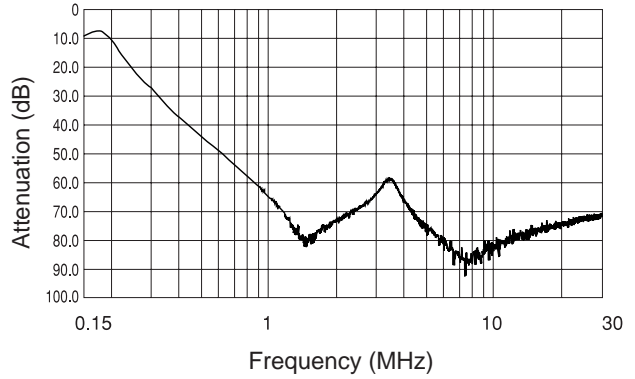

#### MF1216

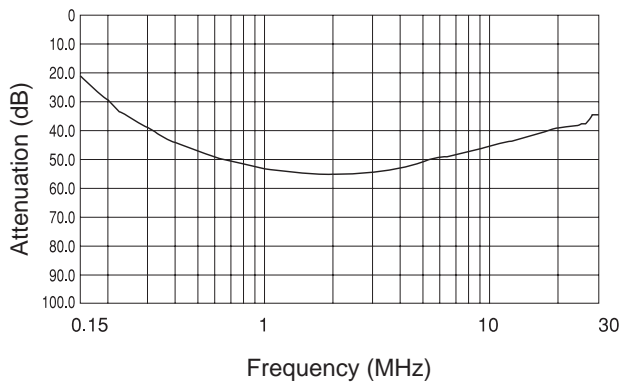

#### MF1216

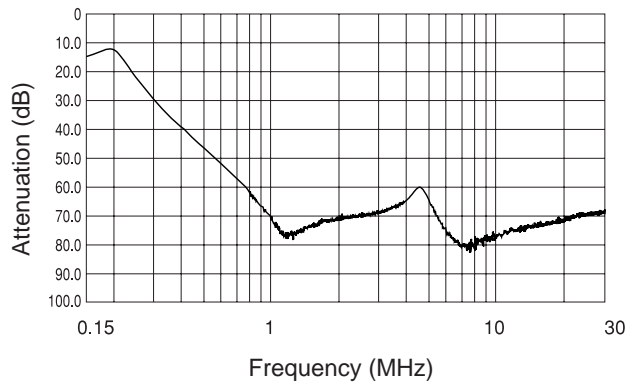

Noise Filter