

SHARP

SPEC No.	EL123065
ISSUE:	Apr. 20 2000

To: _____

SPECIFICATIONS

Product Type : I77-type lens-integrated CMOS Color Area Sensor for CIF

Model No. LZ0P3820

※This specifications contains 24 pages including the cover.
If you have any objections, please contact us before issuing purchasing order.

CUSTOMERS ACCEPTANCE

DATE: _____

BY: _____

PRESENTED

BY: *Y. Kusano*
Y. KUSANO
Dept. General Manager

REVIEWED BY: _____

PREPARED BY:

_____ *K. Sakai*

Product Development Dept. II
CCD Development Center
Integrated Circuits Development
SHARP CORPORATION

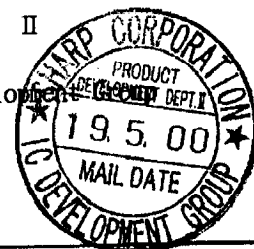

- Handle this document carefully for it contains material protected by international copyright law. Any reproduction, full or in part, of this material is prohibited without the express written permission of the company.
- When using the products covered herein, please observe the conditions written herein and the precautions outlined in the following paragraphs. In no event shall the company be liable for any damages resulting from failure to strictly adhere to these conditions and precautions.

(1) The products covered herein are designed and manufactured for the following application areas. When using the products covered herein for the equipment listed in Paragraph (2), even for the following application areas, be sure to observe the precautions given in Paragraph (2). Never use the products for the equipment listed in Paragraph (3).

- Office electronics
- Instrumentation and measuring equipment
- Machine tools
- Audiovisual equipment
- Home appliances
- Communication equipment other than for trunk lines

(2) Those contemplating using the products covered herein for the following equipment which demands high reliability, should first contact a sales representative of the company and then accept responsibility for incorporating into the design fail-safe operation, redundancy, and other appropriate measures for ensuring reliability and safety of the equipment and the overall system.

- Control and safety devices for airplanes, trains, automobiles, and other transportation equipment
- Mainframe computers
- Traffic control systems
- Gas leak detectors and automatic cutoff devices
- Rescue and security equipment
- Other safety devices and safety equipment, etc.

(3) Do not use the products covered herein for the following equipment which demands extremely high performance in terms of functionality, reliability, or accuracy.

- Aerospace equipment
- Communications equipment for trunk lines
- Control equipment for the nuclear power industry
- Medical equipment related to life support, etc.

(4) Please direct all queries and comments regarding the interpretation of the above three Paragraphs to a sales representative of the company.

- Please direct all queries regarding the products covered herein to a sales representative of the company.

CONTENTS

1. GENERAL DESCRIPTION	P. 2
2. ARRANGEMENT OF PIXELS AND COLOR FILTERS	P. 3
3. BLOCK DIAGRAM	P. 4
4. PIN CONFIGURATION	P. 5
5. PIN DESCRIPTION	P. 6
6. ELECTRIC CHARACTERISTICS	P. 7
7. IMAGING CHARACTERISTICS	P. 8
8. LENS SPECIFICATIONS	P. 9
9. TIMING DIAGRAM	P. 10
10. DESCRIPTION OF SERIAL DATA	P. 13
11. EXAMPLE OF STANDARD OPERATING CIRCUIT	P. 16
12. SPECIFICATION FOR BLEMISH	P. 17
13. CAUTIONS FOR USE	P. 18
14. PACKAGE OUTLINE AND PACKING SPECIFICATION	P. 20

1. GENERAL DESCRIPTION

LZOP3820 is a 1/7-type (approx. 2.6mm) lens-integrated CMOS image sensor. The sensor further includes a timing generator (TG), a correlated double sampling (CDS) circuit, an auto gain control (AGC) circuit and an analog-to-digital converter (ADC) circuit. All the circuits of the sensor can be driven by 3.3V single power supply. Having small lens and small LCC-type flat package, possible to make ultra-small color camera easily.

Features

- 1) Number of image pixels : Horizontal 367 × vertical 291
(approximately 110,000 pixels)
- 2) Square pixel, Pixel pitch : Horizontal 5.6 μ m × vertical 5.6 μ m
- 3) Progressive scan
- 4) Compatible with CIF standard
- 5) Primary color filter composed of R, G, B
- 6) Analog output and 8-bit digital output
- 7) Variable electronic shutter (1/30 to 1/10,000 s)
- 8) Variable gain control (3 to 30 dB)
- 9) Can be operating by DC 3.3V single power supply
- 10) 36-pin half-pitch LCC-type small package
(Base section size: 11.5mm × 11.5mm max.)
- 11) approx. 58° (degrees) of horizontal view angle lens includes.
- 12) Not designed or rated as radiation hardened

Applications

Wireless phone camera
Image capture camera for PC, PDA
Amusement (Game, Toy) etc.

※The circuit diagram and others included in this specification are intended for use to explain typical application examples. Therefore, we take no responsibility for any problem as may occur due to the use of the included circuit and for any problem with industrial proprietary rights or other rights.

2. ARRANGEMENT OF PIXELS AND COLOR FILTERS

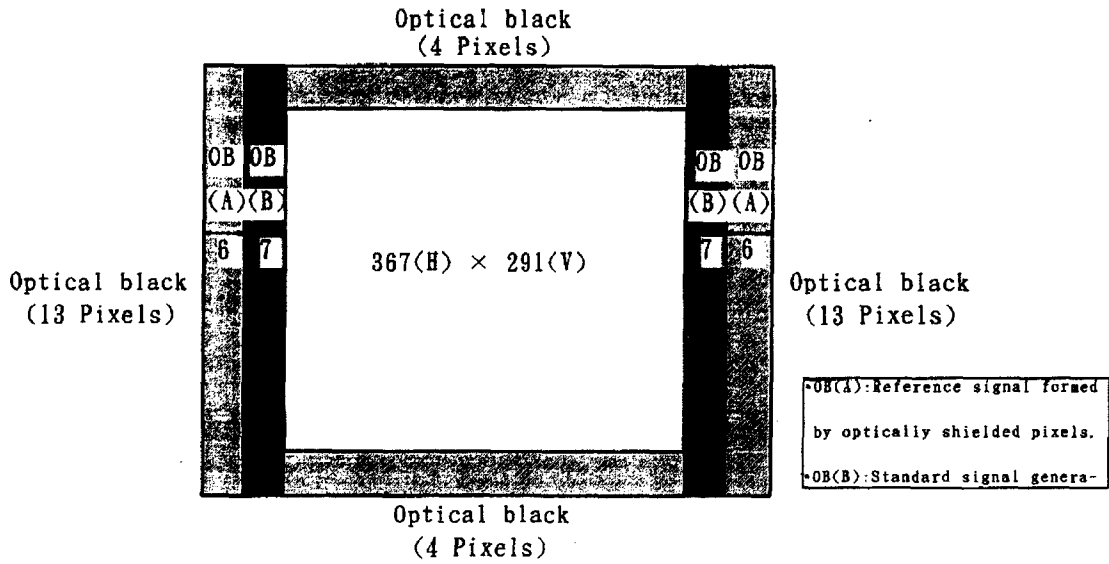

(1, 291)

R	G	R	G	R
G	B	G	B	G
R	G	R	G	R
G	B	G	B	G
R	G	R	G	R
G	B	G	B	G

(367, 291)

R	G	R	G	R
G	B	G	B	G
R	G	R	G	R
G	B	G	B	G
R	G	R	G	R
G	B	G	B	G

G	B	G	B	G
R	G	R	G	R
G	B	G	B	G
R	G	R	G	R
G	B	G	B	G
R	G	R	G	R

G	B	G	B	G
R	G	R	G	R
G	B	G	B	G
R	G	R	G	R
G	B	G	B	G
R	G	R	G	R

(1, 1)

(367, 1)

3. BLOCK DIAGRAM

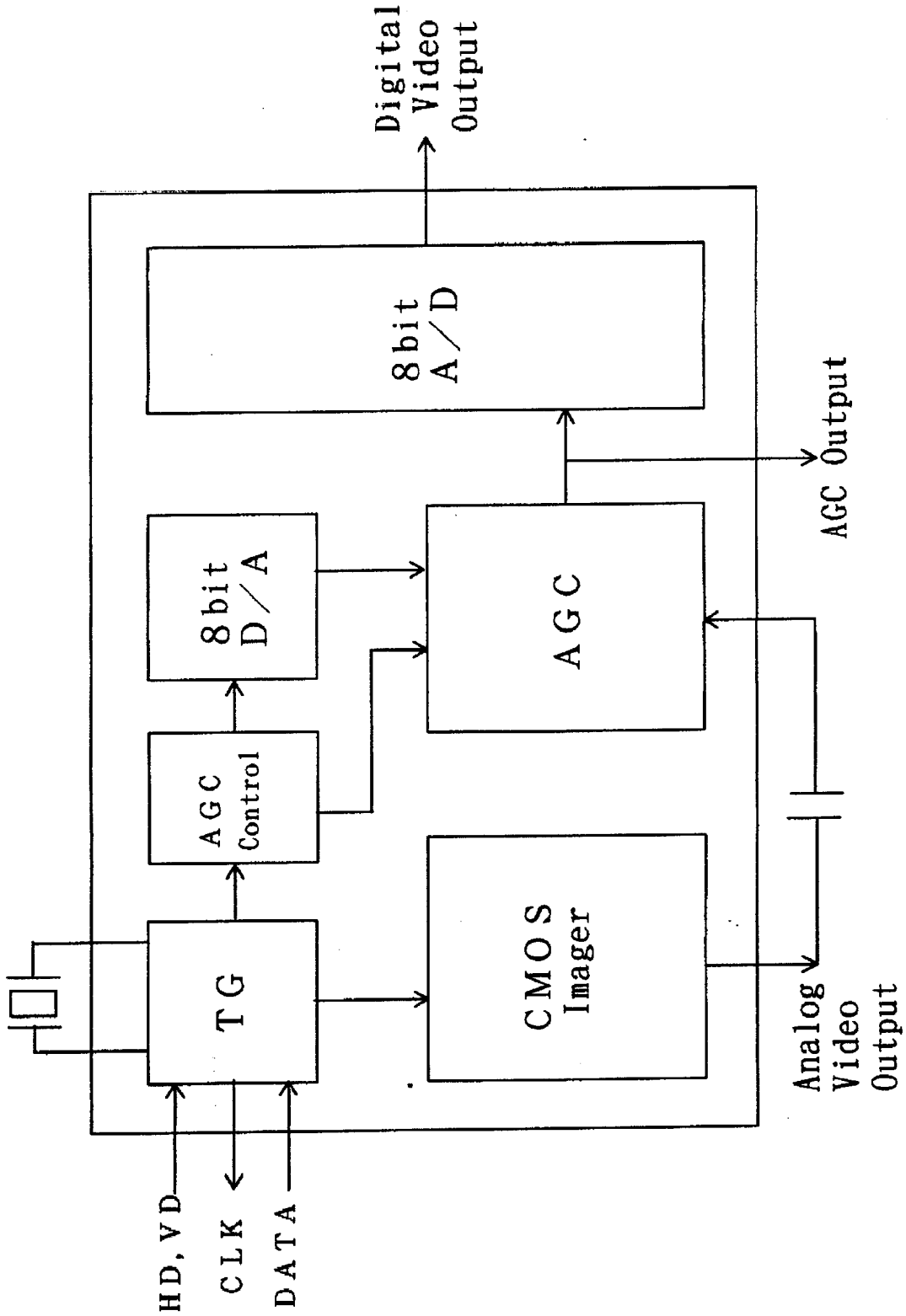

4. PIN CONFIGURATION

(TOP VIEW)

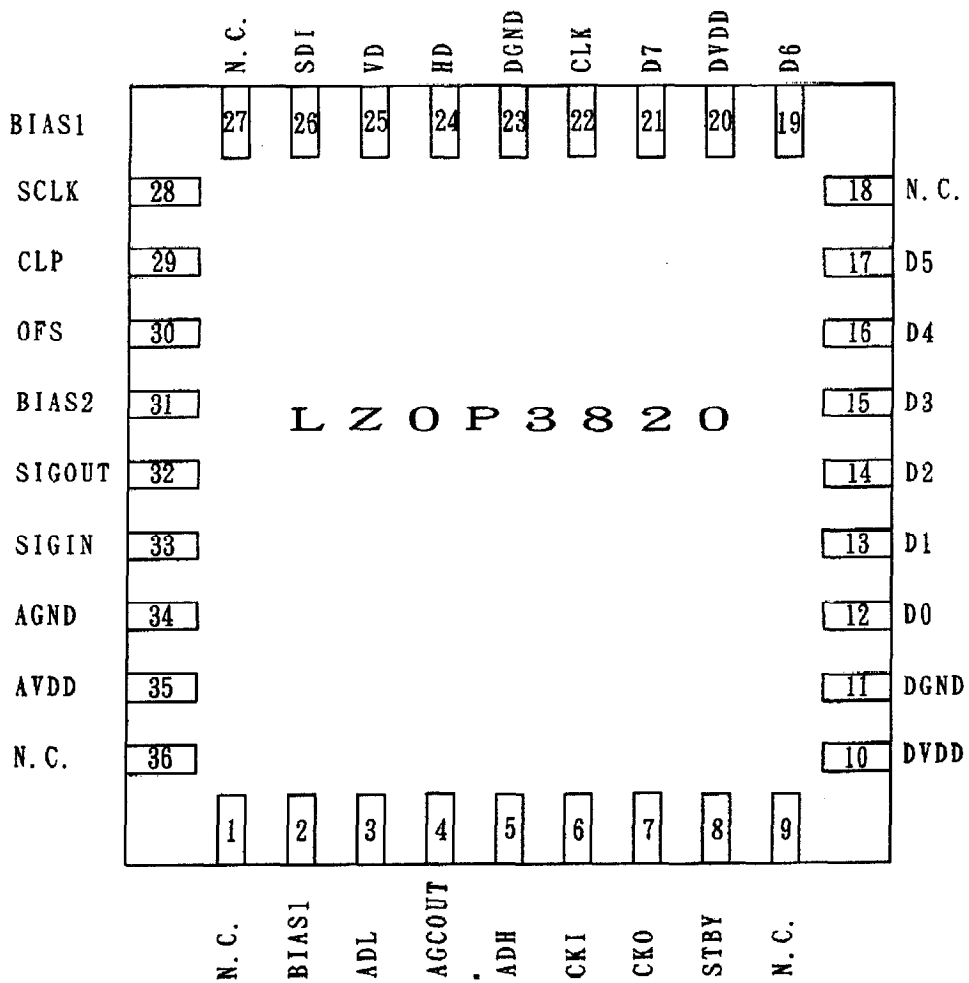

5. PIN DESCRIPTION

Pin No.	Symbol	I/O	A/D	Description
1	N. C.	—	—	No connection
2	BIAS1	—	Analog	Analog bias voltage1 for image sensor
3	ADL	—	Analog	Bottom ADC reference voltage
4	AGCOUT	Output	Analog	AGC output
5	ADH	—	Analog	Top ADC reference voltage
6	CKI	Input	Digital	Clock input for oscillator
7	CKO	Output	Digital	Clock output for oscillator
8	STBY	Input	Digital	Control data input for system disable
9	N. C.	—	—	No connection
10	DVDD	—	Digital	Digital power supply
11	DGND	—	Digital	Digital ground
12	D0	Output	Digital	ADC signal output 0 (LSB)
13	D1	Output	Digital	ADC signal output 1
14	D2	Output	Digital	ADC signal output 2
15	D3	Output	Digital	ADC signal output 3
16	D4	Output	Digital	ADC signal output 4
17	D5	Output	Digital	ADC signal output 5
18	N. C.	—	—	No connection
19	D6	Output	Digital	ADC signal output 6
20	DVDD	—	Digital	Digital power supply
21	D7	Output	Digital	ADC signal output 7 (MSB)
22	CLK	Output	Digital	Reference clock output (9.0MHz)
23	DGND	—	Digital	Digital ground
24	HD	Input	Digital	Horizontal drive pulse input
25	VD	Input	Digital	Vertical drive pulse input
26	SDI	Input	Digital	Control data input (AGC, EE, Offset etc.)
27	N. C.	—	—	No connection
28	SCLK	Input	Digital	Control clock input for SDI
29	CLP	—	Analog	Analog bias voltage for clamp circuit
30	OFS	—	Analog	Offset bias voltage for AGC
31	BIAS2	—	Analog	Analog bias voltage 2 for image sensor
32	SIGOUT	Output	Analog	Analog image signal output
33	SIGIN	Input	Analog	Analog image signal input
34	AGND	—	Analog	Analog ground
35	AVDD	—	Analog	Analog power supply
36	N. C.	—	—	No connection

6. ELECTRIC CHARACTERISTICS

6-1. ABSOLUTE MAXIMUM RATINGS

Parameter	Symbol	Ratings	Unit
Power supply voltage	VDD	-0.3 ~ 4.6	V
Input signal voltage	V ϕ	-0.3 ~ VDD+0.3	V
Storage temperature	Tstr	-20 ~ 70	°C

6-2. RECOMENDED OPERATING CONDITIONS

Parameter	Symbol	MIN	TYP	MAX	Unit	Note
Power supply voltage	VDD	3.0	3.3	3.6	V	
Operating temperature	Topr	-10	25	60	°C	
Oscillator frequency	Fck		9.0		MHz	
Digital input voltage	Low level	V ϕ L		0.2VDD	V	1
	High level	V ϕ H	0.8VDD	VDD	V	
Analog input voltage		(Connect to terminal through capacitor)				2
Analog bias voltage		(Connect to GND through capacitor)				3

Note 1 : Apply to input pins HD, VD, SDI and SCLK.

Note 2 : Apply to input pin SIGIN. Please do not connect to DC directly.

Note 3 : Apply to pins BIAS1, BIAS2, OFS, ADL, DAL, CLP.

Please do not connect to GND directly.

7. IMAGING CHARACTERISTICS

Readout mode : 1/30 sec, Normal mode

Ambient temperature : 25 °C

Driving voltage : 3.3 V

Color temperature of light source : 3200K

• Measurement point : Analog image signal output (pin no.32) before AGC and AD.

No.	Parameter	Symbol	Note	Min.	Typ.	Max.	Unit
1	Standard output voltage	V _o	(a)		150		mV
2	Saturation output voltage	V _{sat}	(b)		800		mV
3	Dark output voltage	V _{dark}	(c)				mV
4	Dark signals non-uniformity	DSNU	(d)				mV
5	Sensitivity (Green channel)	R(G)	(e)		300		mV
6	Vertical line Fixed Pattern Noise	VFPN	(f)		0.5		mVp-p
7	Resolution (at center)		(g)	150			TV Line
8	Resolution (at corner)		(h)	100			TV Line
9	Shading		(i)		30		%
10	Difference of center		(j)			±10	%
11	Current dissipation	IVDD	(k)		18		mA

【Note】

- (a) V_o is the average output voltage of Green channel in the central area(H/10, V/10) under uniform illumination. The standard exposure condition is defined when V_o is 150 mV.
- (b) The image area is divided into 10 × 10 segments under 10 times exposure of the standard exposure condition. The segment's voltage is the average output voltages of all pixels within the segments. V_{sat} is the minimum segment's voltage of all the segments voltage.
- (c) V_{dark} is the difference between average output voltage of the effective area and that of the OB area, under non-exposure condition.
- (d) Image area is divided into 10 × 10 segments under non-exposure condition. DSNU is defined by (V_{dmax} - V_{dmin}), where V_{dmax} and V_{dmin} are the maximum and minimum values of all the segments voltage, respectively.
- (e) R(G) is the average output voltage of Green channel at central area(H/10, V/10) when a 1000 lux light source on a 90% reflector is image.
- (f) One mean horizontal line signal <bi> is obtained by adding all the horizontal line signals <aij> vertically and dividing them by the line number. <xi> is the deviation of the center pixel from the average of successive 5 pixels in <bi>. V-FPN is the maximum absolute value of <xi>.
- (g) The limited resolution in the central area(H/10, V/10) which the image of TV resolution chart(ex. EIAJ test chart:type-A) can be distinguished on the B/W video monitor when converted into composite video signal.
- (h) The limited resolution in the peripheral area(image height:Y=0.7) under the conditions mentioned above.
- (i) Defined following formula at the brightness of standard output voltage. [at G-channel]

$$(V_{co}/V_{ce}) \times 100 [\%]$$
V_{co}: output voltage of edge of the image. (image height:Y=0.8)
V_{ce}: output voltage of center of the image.
- (j) Difference of center between image and monitor. Ratio of horizontal underscanning monitor size.
- (k) IVDD is the total current of analog and digital power supply in the dark and on the standard load condition.

8. LENS SPECIFICATIONS

No	Parameter	Specifications	Note
1	Lens Structure	Prastic, Non-spherical, single lens	
2	Focal Length	2.0 mm \pm 5%	
3	F No.	2.8 \pm 5%	
4	Angle of View	Horizontal: approx. 58° [typ. : Reference]	(a)
5	TV Distortion	-4.2%	(b)
6	Focus Adjustment Range	∞ ~ 10 cm	(c)
7	Torque of Focusing	0.00005 ~ 0.001 N·m	(d)

【Conditions】

(a) Effective Image Area : (H)2.06 × (V)1.63mm

(b) TV distortion is defined the formura, $(\Delta y / Y) \times 100$ [%]

at capturing rectangular pattern sized Horizontal by Vertical as 4by 3.

"Y" is defined as the Vertical height of center of Horizontal line.

"y" is defined as the Vertical height of edge of Horizontal line.

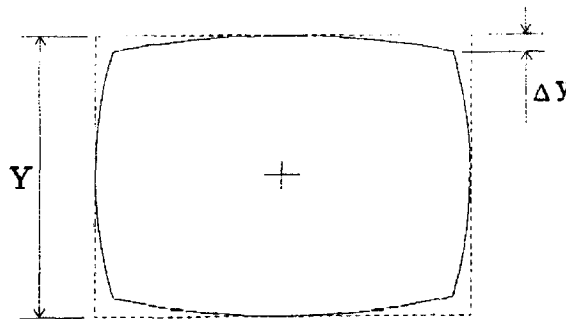

(c) The range is the best points by adjustment by screwing the lens head.

(d) Torques which are necessary for turning the lens.

(at shipping of products)

9. TIMING DIAGRAM

9-1. Horizontal Pulse Timing

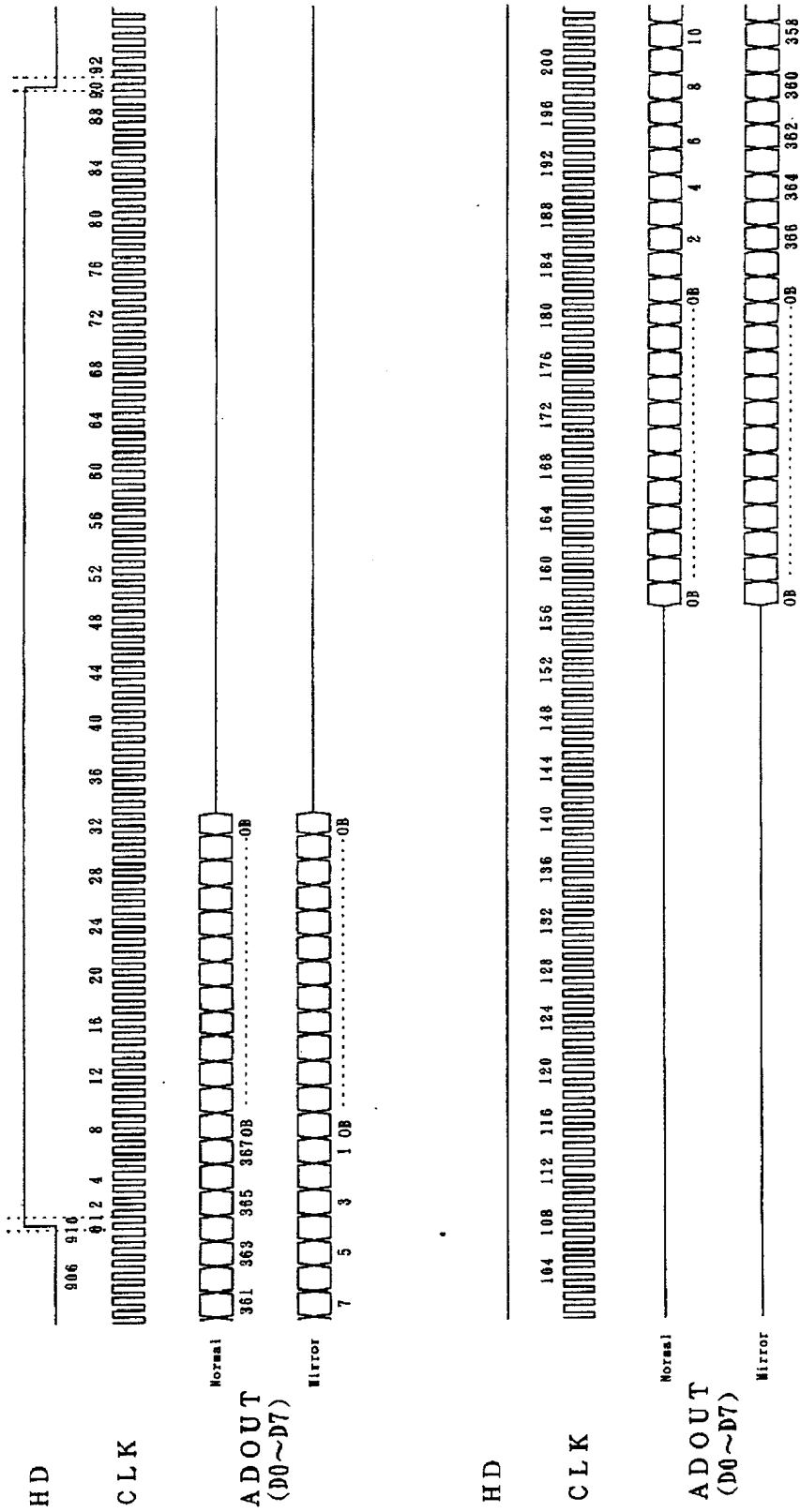

- The rising edge of HD pulse must be between two rising edges of CLK(0) and CLK(1).
- The falling edge of HD pulse must be between two rising edges of CLK(90) and CLK(91).

9-2. Phase relations between Digital Output (ADOUT) and Clock (CLK).

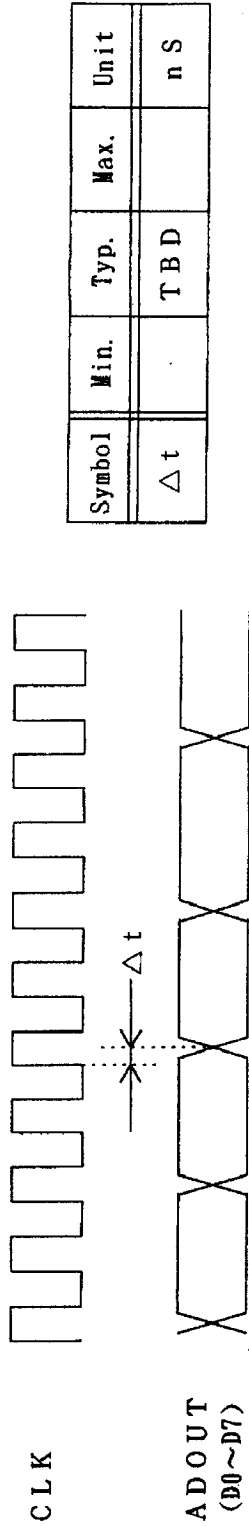

9-3. Vertical Pulse Timing

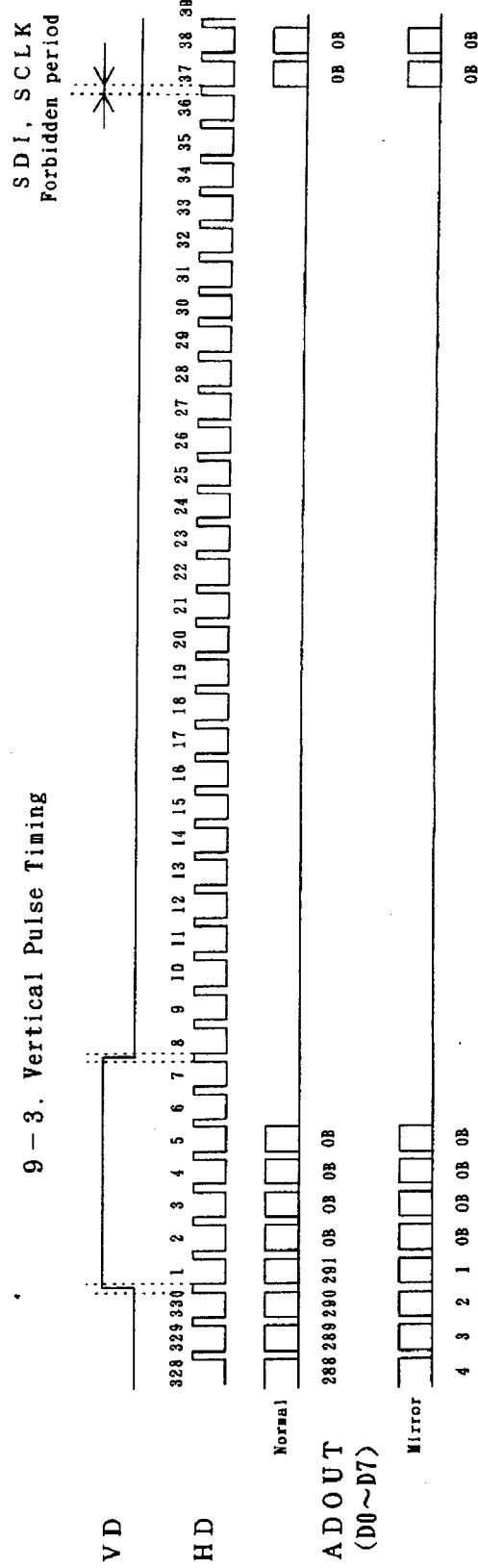

• The rising edge and falling edge of VD pulse must be in high period of HD pulses.

9-4. Serial Data Timing (SDI, SCLK)

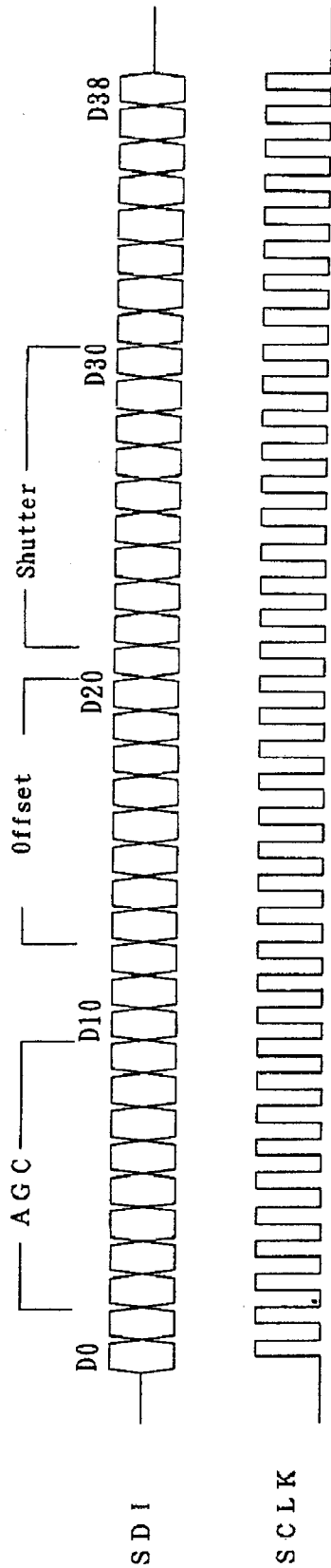

- Data in SDI are taken at the rising edge of SCLK.
- Clock frequency of SCLK should be less than 1/2 of that of CLK.
- Do not insert the pulses SDI and SCLK between 36H and 37H, that is described in section 9-3.
- The contents of serial data from D0 to D38 are referred to "Section 10. Description of Serial Data".

10. DESCRIPTION OF SERIAL DATA

Address	Symbol	Function	
D0		No use	
D1		(Fix to Low level)	
D2	AGC6 (MSB)	Auto gain control (0 to 20 dB)	
D3	AGC5		
D4	AGC4		
D5	AGC3		
D6	AGC2		
D7	AGC1		
D8	AGC0 (LSB)		
D9			
D10		No use	
D11		(Fix to Low level)	
D12			
D13	OFS7 (MSB)	Offset level control of AGC output (0.9 to 1.5 V)	
D14	OFS6		
D15	OFS5		
D16	OFS4		
D17	OFS3		
D18	OFS2		
D19	OFS1		
D20	OFS0 (LSB)		
D21		No use (Fix to Low level)	
D22	SHT8 (MSB)	Shutter speed control (Exposure time is 1 to 1/330 frame period)	
D23	SHT7		
D24	SHT6		
D25	SHT5		
D26	SHT4		
D27	SHT3		
D28	SHT2		
D29	SHT1		
D30	SHT0 (LSB)		
D31	MIRH		H:Horizontal mirror inversion image, L:Normal image
D32	MIRV		H:Vertical mirror inversion image, L:Normal image
D33	SAD1 (MSB)	Phase select of AD clock (Fix to Low level)	
D34	SAD0 (LSB)		
D35	MAX2 (MSB)	Fixed gain select (3 to 10 dB)	
D36	MAX1		
D37	MAX0 (LSB)		
D38	LPMD	H:Power save mode (AGC and AD off), L:All active	

10-3. SETTING OF SHUTTER SPEED

- One LSB of shutter speed code represents 1H, where 1H is HD pulse period.
- Shutter speed values at typical codes are shown below.

Shutter speed (Exposure time Unit:H)	D 2 2	D 2 3	D 2 4	D 2 5	D 2 6	D 2 7	D 2 8	D 2 9	D 3 0
330	L	L	L	L	L	L	L	L	L
329	L	L	L	L	L	L	L	L	H
328	L	L	L	L	L	L	L	H	L
.									
300	L	L	L	L	H	H	H	H	L
.									
.									
200	L	H	L	L	L	L	L	H	L
.									
.									
100	L	H	H	H	L	L	H	H	L
.									
.									
10	H	L	H	L	L	L	L	L	L
.									
3	H	L	H	L	L	L	H	H	H
2	H	L	H	L	L	H	L	L	L
1	H	L	H	L	L	H	L	L	H

10-4. SETTING OF FIXED GAIN

- One LSB of gain code represents 1dB.

Fixed gain (dB)	D 3 5	D 3 6	D 3 7
3	L	L	L
4	L	L	H
5	L	H	L
6	L	H	H
7	H	L	L
8	H	L	H
9	H	H	L
10	H	H	H

11. EXAMPLE OF OPERATING CIRCUIT

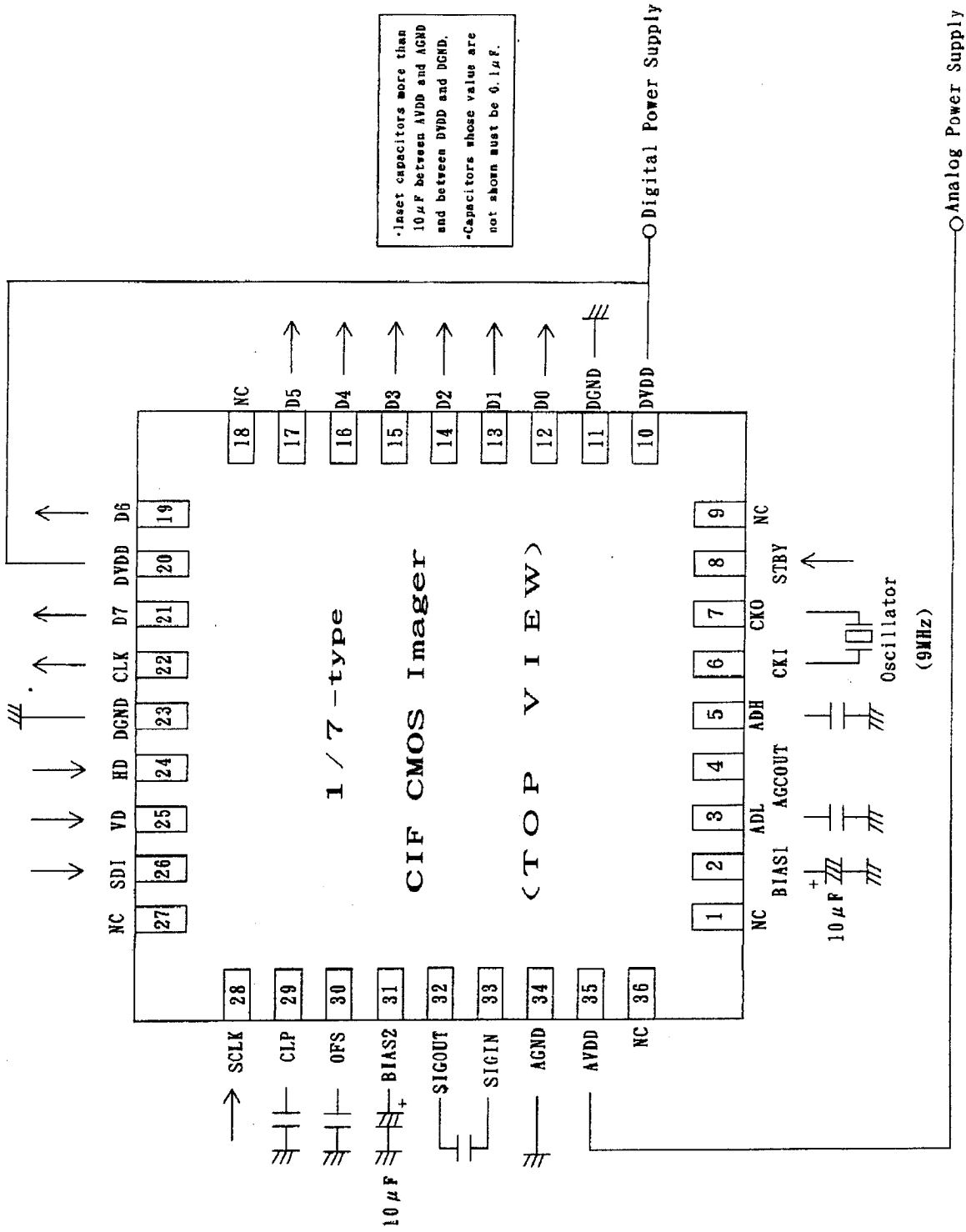

12. SPECIFICATION FOR BLEMISH

◀ To be determined ▶

1) Definition of blemish

- Size of blemish : ≤ 3 lines square by vertical lines.
- [For reference] • Size of stain : ≥ 4 lines square by vertical lines.

	Level of blemish (mV)	Permitted number of blemish	Note
White blemish (Exposed)	$\leq B$		• $V_{out} = V_{std}$ (Green channel : 150mV) *Refer to note below
	$B <$		
Black blemish (Exposed)	$\leq B$		
	$B <$		
White blemish (Non_exposed)	$\leq B$		
	$\leq B <$		
	$\leq B <$		
	$B <$		

(note)

- B : Blemish level defined in fig. below.
- V_{out} : Average output voltage at Green channel.
- V_{std} : 150 mV. The standard output voltage defined in the specification of " 7. Imaging Characteristics "

2) Measureing conditions

- Operating temperature : $T_{opr} = 25^{\circ}C$
- Operating voltage : $V_{DD} = 3.3V$
- Measureing point : Analog image signal output(Pin No. 32) before AGC and AD.

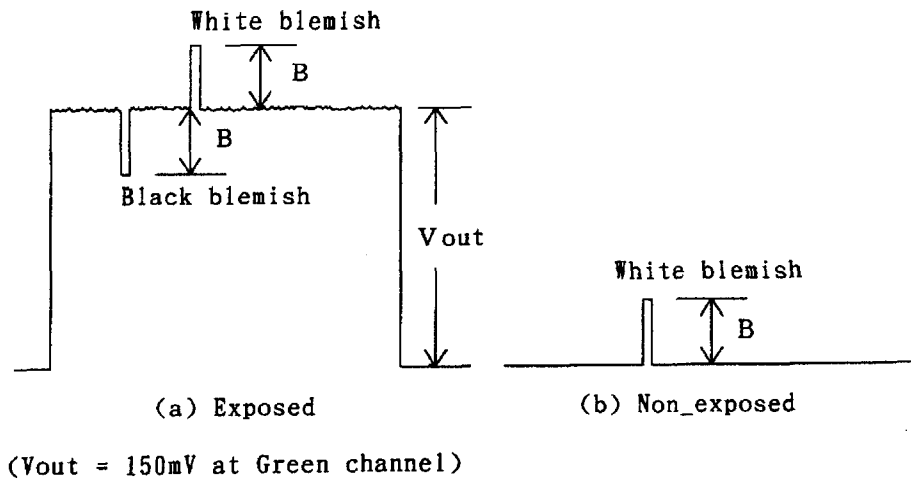

fig. Definition of blemish level

13. CAUTIONS FOR USE

1. Package breakage

In order to prevent the package, the lens holder and lens from being broken, follow the instructions below:

1) This CMOS image sensor is a precise optical component and the package-base material is ceramic. Therefore, please be careful about the following instructions.

- Take care not to drop the device when mounting, handling, or transporting.
- Avoid giving a shock to the package. Especially when leads are fixed to the shocks or the circuit board, a small shock could break the package more easily than when the package isn't fixed.

2) If any damage or breakage occur on the surface of the lens, its characteristics could deteriorate.

Therefore,

- Do not hit the Lens.
 - Do not give a shock large enough to cause distortion.
 - Do not scrub or scratch surface of the lens.
- Even a soft cloth or applicator, if dry, could cause dust to scratch the Lens.

2. Electrostatic Damage

As compared with general MOS-LSI, CMOS image sensor has lower ESD.

Therefore, take the following anti-static measures when handling the CMOS image sensor.

- 1) Always discharge static electricity by grounding the human body and the instrument to be used. To ground the human body, provide resistance of about $1M\Omega$ between the human body and the ground to be on the safe side.
- 2) When directly handling the device with the fingers, hold the lens holder and do not touch the lead.
- 3) To avoid generating static electricity,
 - a. do not scrub the body and lens surface with cloth etc.
 - b. do not attach any tape or labels.
- 4) When storing or transporting the device, put it in a container of conductive material.

3. Dust and contamination

Dust or contamination on the surface of lens and the inside of the lens holder could deteriorate the output characteristic or cause a scar. In order to minimize dust or contamination on the device, take the following precautions:

- 1) Do not remove the lens from the body.
Especially when adjusting macro, be careful not to remove the lens by turning it counterclockwise too much.
- 2) Do not touch the surface of the lens with the fingers. If dust or contamination gets on the surface of the lens, the following cleaning method is recommended:
 - Handle the built-in lens CMOS image sensor in a clean environment such as a cleaned booth.
(The cleanliness level should be, if possible, if possible class 1000 at least.)
 - Dust from static electricity should be blown off with an ionized air blower.
For anti-electrostatic measures, however, ground all the leads on the device before blowing off the dust.
 - The contamination on the surface of the lens should be wiped off with a clean applicator soaked in isopropyl alcohol. Wipe slowly and gently in one direction only.
 - Frequently replace the applicator and do not use the same applicator to clean more than one device.
 - Make sure there is no dust or contamination on the lens and screw it on the lens holder.

4. Other

- 1) Soldering measure and condition.
 - Use ESD-measured soldering iron.
 - Do not put too much force onto the lens and the lens holder while soldering.
 - Be careful not to let the soldering iron touch the lens holder.
 - Soldering can be quickly/neatly done by laying the soldering iron so it lightly touches the border between the package and the circuit board and sliding it in sideways.
- 2) There is no guarantee of the performance of the device which has been removed or resoldered after being soldered once under the conditions mentioned above.
- 3) Avoid using or storing the CMOS image sensor at high temperature or high humidity as it is a precise optical component. Do not give a mechanical shock to the CMOS image sensor.
- 4) Do not expose the device to strong light. For the color device, long exposure to strong light will fade the color of the color filters.

1 4. PACKAGE OUTLINE AND PACKING SPECIFICATION

1. Package Outline Specification

Refer to attached drawing

2. Markings

Marking contents

- (1) Product name : LZOP3820
- (2) Company name : SHARP
- (3) Country name : JAPAN
- (4) Date code : YY WW D XX

Denotes the production ref. code. (1~2figures)

Denotes the production day of the week.

1	2	3	4	5	6	7
SUN.	MON.	TUE.	WED.	THU.	FRI.	SAT.

Denotes the production week.

(01, 02, 03,, 52, 53)

Denotes the production year.

(Lower two digits of the year.)

Positions of markings are shown in the package outline drawing.

But, markings shown in that drawing are not provided any measurements of their characters and their positions.

3. Packing Specification

3 - 1. Packing materials

Material Name	Material Spec.	Purpose
Device case	Cardboard(100devices/case)	Device tray fixing
Device tray	Conductive plastic (50devices/tray)	Device packing(2trays/case)
Cover tray	Conductive plastic(2trays/case)	Device packing
Rubber band		Device tray fixing
Buffer	Cardboard	Shock absorber of device tray
Cushion bag	Conductive	Device tray fixing
Tape	Paper	Sealing cushion bag and device case
Label	Paper	Indicates part number, quantity and date of manufacture

3 - 2. External appearance of packing

Refer to attached drawing

4. Precaution

- 1) Before unpacking, confirm the imports of the chapter "13. CAUTIONS FOR USE" in this device specifications.
- 2) Unpacking should be done on the stand treated with anti-ESD. At that time, the same anti-ESD treatment should be done to operator's body, too.

ISSUE NUMBER

(NOTE)

LC-HS3820A

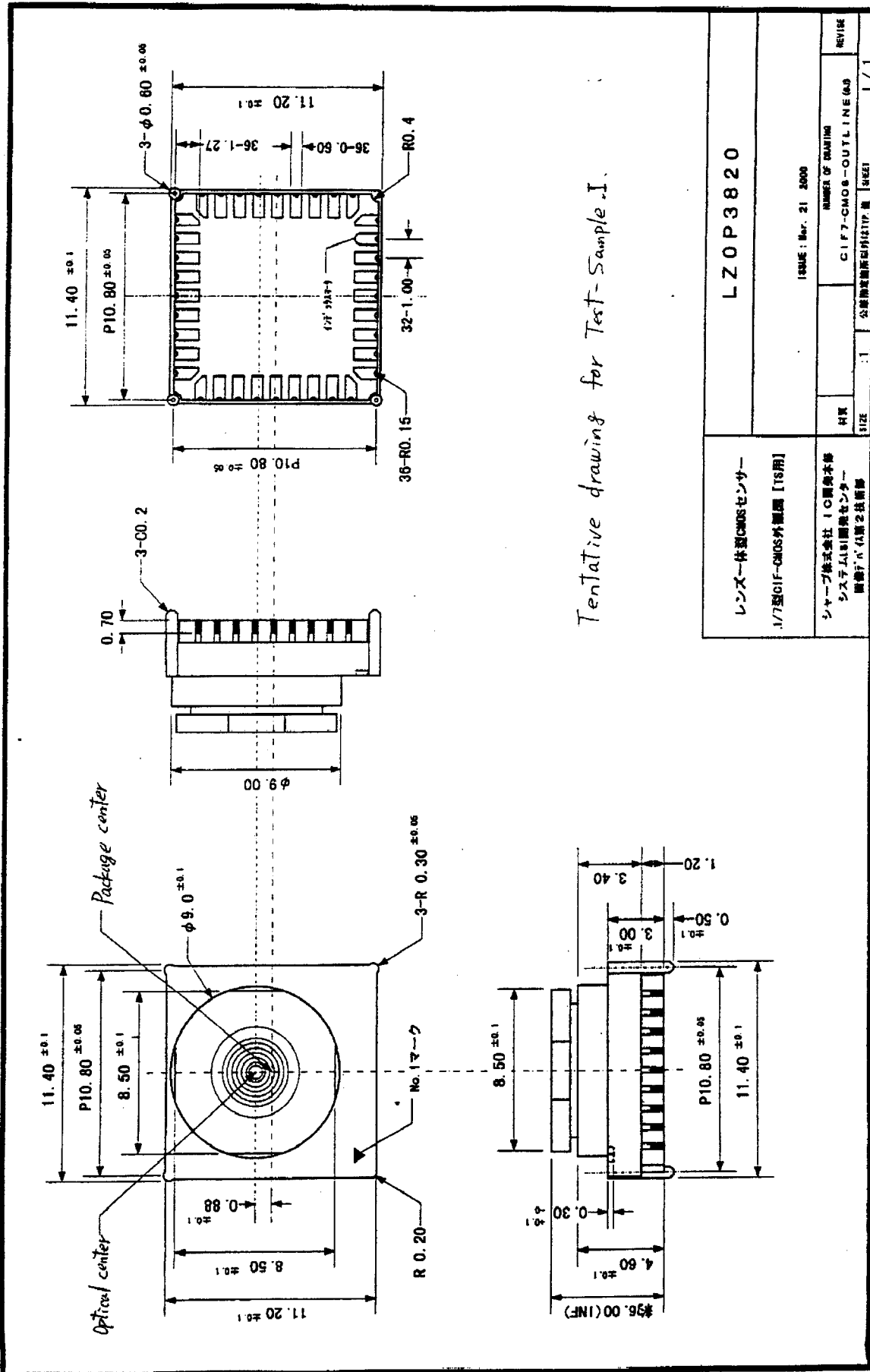

Tentative drawing for Test-Sample I.

レンズ一体型CMOSセンサー		LZOP3820	
1/7型GIF-CMOS外観図 [TS用]		ISSUE : Mar. 21 2000	
社名	シャープ株式会社 I C開発本部	NUMBER OF DRAWING	1 / 1
社名	システムLSI開発センター	CIF7-CMOS-OUTLINE (A3)	REVISE
社名	興産パナソニック 2技術部	公認測定標準品仕様書 (SHEET)	1 / 1

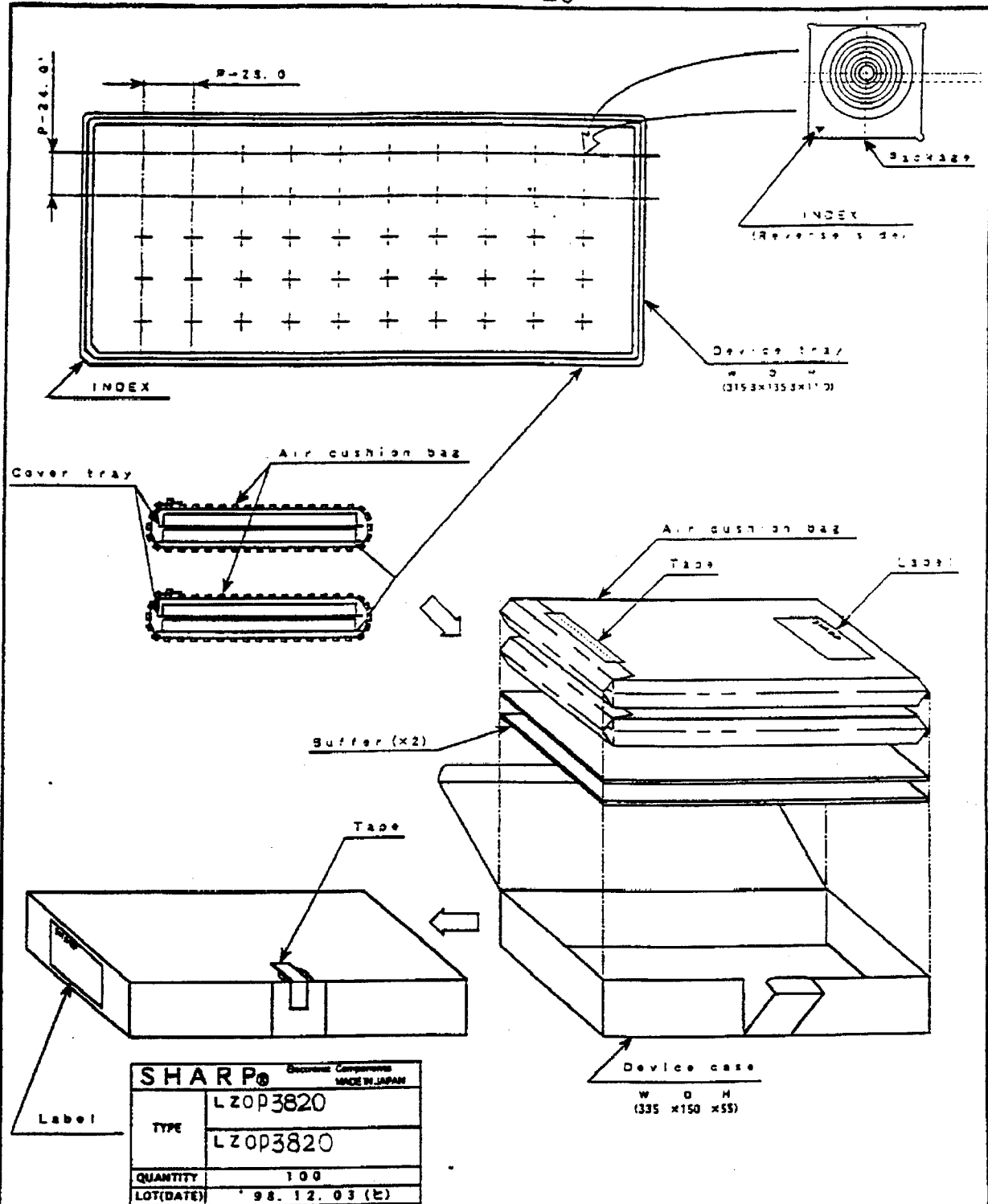

(UNIT : mm)

材質 MATERIAL	仕上 FINISH	名称 NAME	External Appearance of Packing
		コード CODE	
MODULE ASSEMBLY APPLICATION ENGINEERING DEPARTMENT		図番 DRAWING No.	LC-HZ3820A
INTEGRATED CIRCUITS (IC) GROUP			
SHARP CORPORATION			