



LG1626DXC Modulator Driver

Features

- High data-rate optical modulator driver
- Adjustable output voltage up to 3 Vp-p ($R_L = 50 \Omega$)
- Adjustable modulator dc offset
- Operation up to 3 Gbits/s
- Single ended or differential inputs
- Single -5.2 V power supply
- 90 ps rise and fall times
- Enable control

Applications

- SONET/SDM transmission systems
- SONET/SDM test equipment
- Optical transmitters

Functional Description

The LG1626DXC is a gallium-arsenide (GaAs) integrated circuit used to provide voltages to drive optical modulators in high-speed non-return-to-zero (NRZ) transmission systems. The device is made in a high-performance $0.9 \mu\text{m}$ gate GaAs hetero-junction FET technology that utilizes high-density MIM capacitors, airbridge interconnect, and NiCr film precision resistors. The device contains four cascaded stages, operates with a single -5.2 V power supply, and accepts ECL 100K level inputs. The output is an open drain designed to drive 50Ω loads. Voltages control the output modulation amplitude and modulator dc offset. A -2.5 V band-gap reference is required for stable operation over temperature and varying power supply voltage. The LG1626DXC is available in a 24-lead hermetic, gull-wing package.

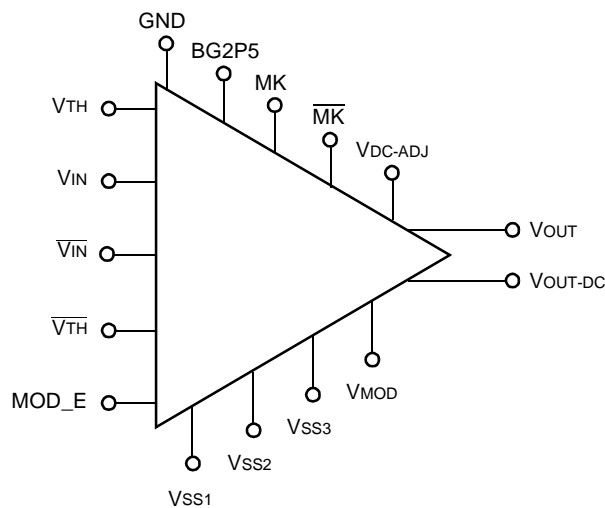
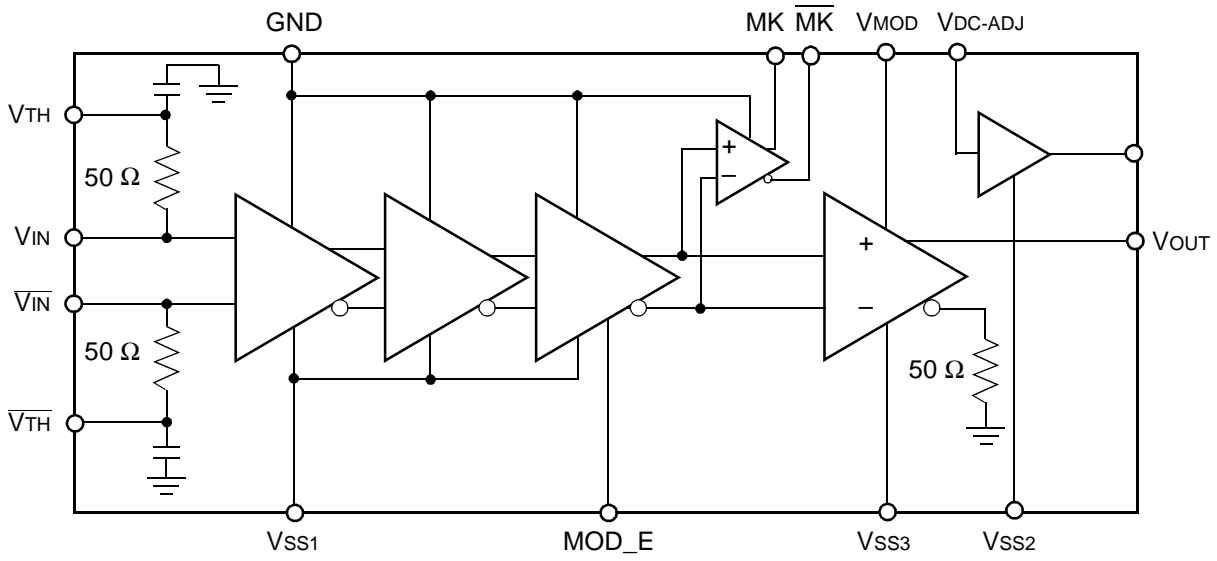

Figure 1. Functional Diagram

Pin Information



5-6550(F)

Figure 2. LG1626DXC Die Block Diagram

Pin Information (continued)

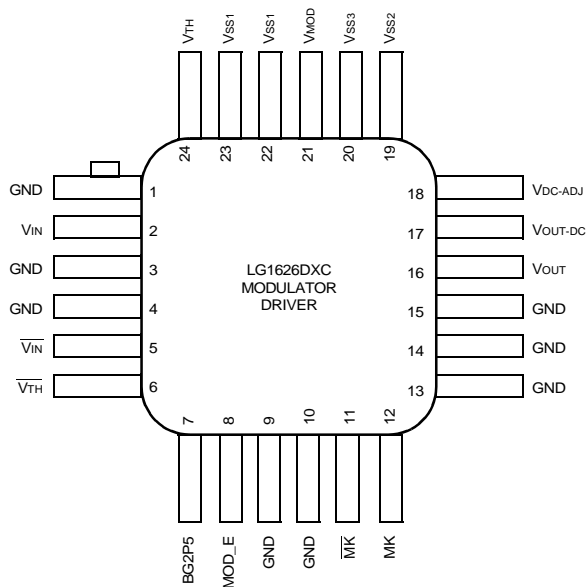

5-6551(F)

Note: Figure is not to scale.

Figure 3. LG1626DXC Package Pinout

Table 1. LG1626DXC Pin Description

Symbol	Pin	Description
GND	1, 3, 4, 9, 10, 13, 14, 15, Package Bottom	Ground. For optimum performance, the package bottom must be soldered to the ground plane.
V _{IN}	2	Data input.
\overline{V}_{IN}	5	Complementary data input.
\overline{V}_{TH}	6	Complementary threshold control (eye crossing) input.
BG2P5	7	-2.5 V band-gap reference (<i>National Semiconductor</i> * LM4040).
MOD_E	8	Modulation enable (connect to V _{SS1} to enable, float to disable).
\overline{MK}	11	Complementary mark density output.
MK	12	Mark density output.
V _{OUT}	16	Output, ac couple to 50 Ω modulator.
V _{OUT-DC}	17	Output, modulator dc offset.
V _{DC-ADJ}	18	Modulator dc offset control input.
V _{SS2}	19	V _{SS2} supply -5.2 V for output prebias.
V _{SS3}	20	V _{SS3} supply -5.2 V for output modulation.
V _{MOD}	21	Output modulation control input.
V _{SS1}	22, 23	V _{SS1} supply -5.2 V.
V _{TH}	24	Threshold control (eye crossing) input.

* *National Semiconductor* is a registered trademark of National Semiconductor Corporation.

Absolute Maximum Ratings (at TA = 25 °C unless otherwise specified)

Table 2. Absolute Maximum Ratings

Parameter	Symbol	Min	Max	Unit
Supply Voltage	VSS	—	5.75	V
Input Voltage	VI	GND	VSS	V
Power Dissipation	PD	—	1	W
Storage Temperature Range	Tstg	-40	125	°C
Operating Temperature Range	Tc	0	100	°C

Handling Precautions

Although protection circuitry has been designed into this device, proper precautions should be taken to avoid exposure to electrostatic discharge (ESD) during handling and mounting. Lucent employs a human-body model (HBM) and a charged-device model (CDM) for ESD-susceptibility testing and protection design evaluation. ESD voltage threshold are dependent on the circuit parameters used to define the model. No industry-wide standard has been adopted for the CDM. However, a standard HBM (resistance = 1500 Ω, capacitance = 100 pF) is widely used and therefore, can be used for comparison. The HBM ESD threshold presented here was obtained by using these circuit parameters.

Table 3. ESD Threshold Voltage

Human-Body Model ESD Threshold	
Device	Voltage
LG1626DXC	>200 V

Mounting and Connections

Certain precautions must be taken when using solder. For installation using a constant temperature solder, temperatures of under 300 °C may be employed for periods of time up to 5 seconds, maximum. For installation with a soldering iron (battery operated or nonswitching only), the soldering tip temperature should not be greater than 300 °C and the soldering time for each lead must not exceed 5 seconds. This device is supplied with solder on the back of the package. For optimum performance, it is recommended to solder the back of the package to the ground.

Electrical Characteristics

$T_A = 25\text{ }^\circ\text{C}$, $V_{SS1} = V_{SS2} = V_{SS3} = -5.2\text{ V}$, $V_{TH} = -1.3\text{ V}$, $V_{MOD} = -3.8\text{ V}$, $R_L = 50\ \Omega$.

Minimum and maximum values are testing requirements. Typical values are characteristics of the device and are the result of engineering evaluations. Typical values are for information purposes only and are not part of the testing requirements. Stresses in excess of the absolute maximum ratings can cause permanent damage to the device.

Table 4. LG1626DXC Minimum and Maximum Values

Parameter	Symbol	Min	Typ	Max	Unit
Data Input Voltage (peak to peak) Single Ended	V_{IN}	300	600	1000	mV
Voltage Control for Output Modulation Current	V_{MOD}	-5.5	—	-4	V
Maximum Modulated Output Voltage ¹	V_{OUT}	2.70	—	3.00	V
Minimum Modulated Output Voltage ²	V_{OUT}	0	—	0.2	V
Output Rise and Fall Times (20%—80%)	t_R, t_F	—	90	—	ps
Power Supply Voltage	$V_{SS1}, V_{SS2}, V_{SS3}$	-5.5	-5.2	-4.9	V
Power Supply Current ³	I_{SS1}	100	140	180	mA
Mark Density ⁴	MK	—	-0.5	—	V
Complementary Mark Density ⁴	\overline{MK}	—	-0.5	—	V
Voltage Control for Modulator dc Offset	V_{DC-ADJ}	-5.5	—	-3	V
Maximum Output, Modulator dc Offset ⁵	V_{OUT-DC}	1.2	—	1.5	V
Minimum Output, Modulator dc Offset ⁶	V_{OUT-DC}	0	—	0.1	V

1. Maximum output modulation at maximum V_{MOD} ($R_L = 50\ \Omega$).

2. Minimum output modulation when MOD_E is floating and $V_{MOD} = V_{SS3}$.

3. Excludes I_{PRE} and average I_{MOD} :

Power supply current I_{SS2} (relating to prebias) is dependent on V_{PRE} .

Power supply current I_{SS3} (relating to modulation) is dependent on V_{MOD} .

4. Both MK and \overline{MK} are open drains, the typical value is obtained by driving a $1\text{ k}\Omega$ load.

5. Maximum modulator dc offset voltage ($R_L = 50\ \Omega$) at maximum V_{DC-ADJ} .

6. Minimum modulator dc offset voltage ($R_L = 50\ \Omega$) at $V_{DC-ADJ} = V_{SS2}$.

Note: All parameters measured at $25\text{ }^\circ\text{C}$ ambient.

Electrical Characteristics (continued)

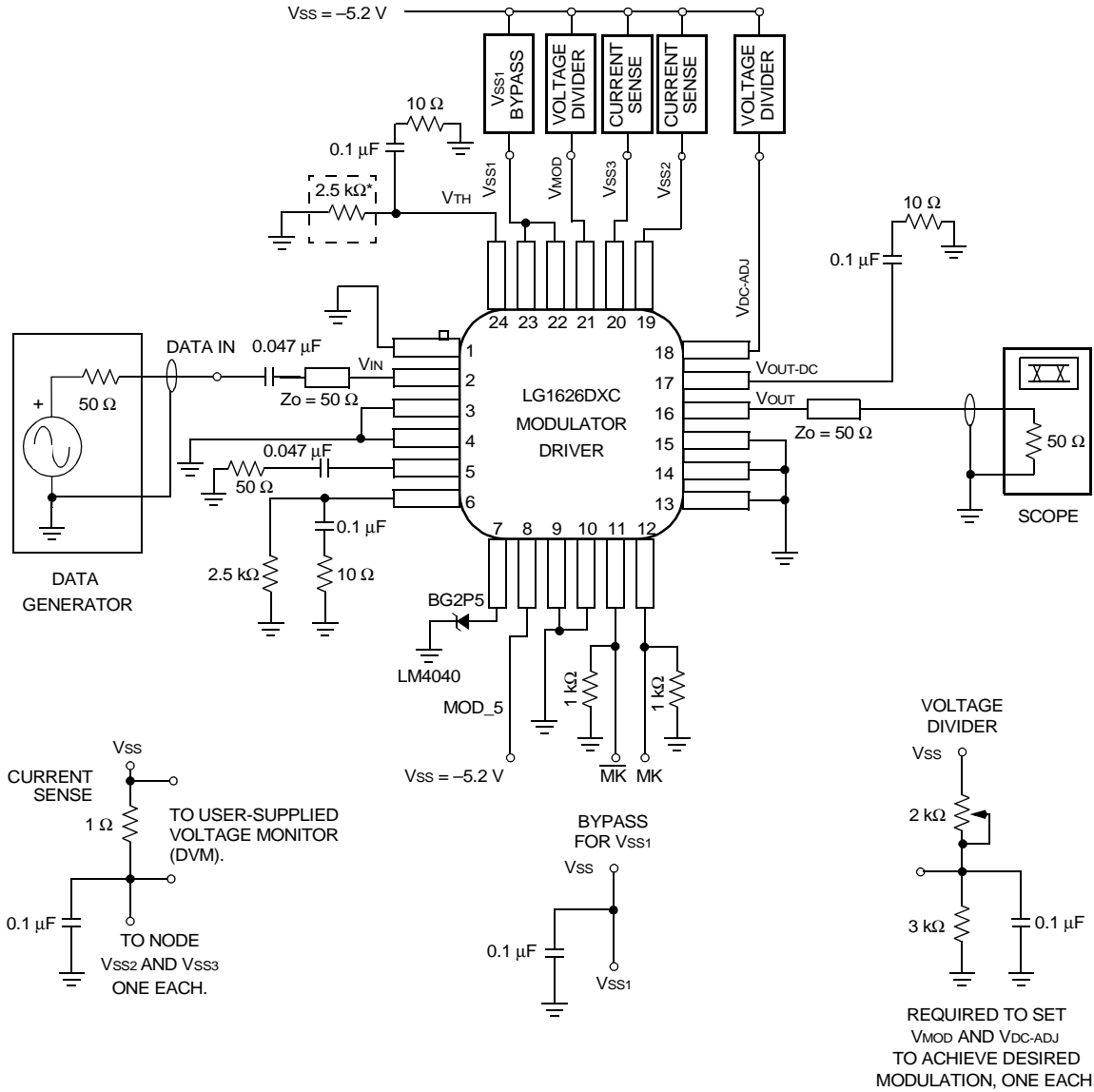

5-6553(F).b

*A 2.5 kΩ resistor will set the eye crossing at 50%. A 5 kΩ potentiometer will allow the eye crossing to be varied.

Notes:

All bypass caps should be mounted close to the package.

I_{SS3} can be measured and used to control V_{MOD}.

I_{SS2} can be measured and used to control V_{OUT-DC}.

For optimal performance, the proximity of the two components should be minimized and the package bottom must be soldered to the circuit board (GND).

For proper impedance matching, high-speed transmission lines should be 50 Ω controlled impedance lines.

Figure 4. LG1626DXC Typical Electrical Evaluation (ac Coupled to Scope)

Electrical Characteristics (continued)

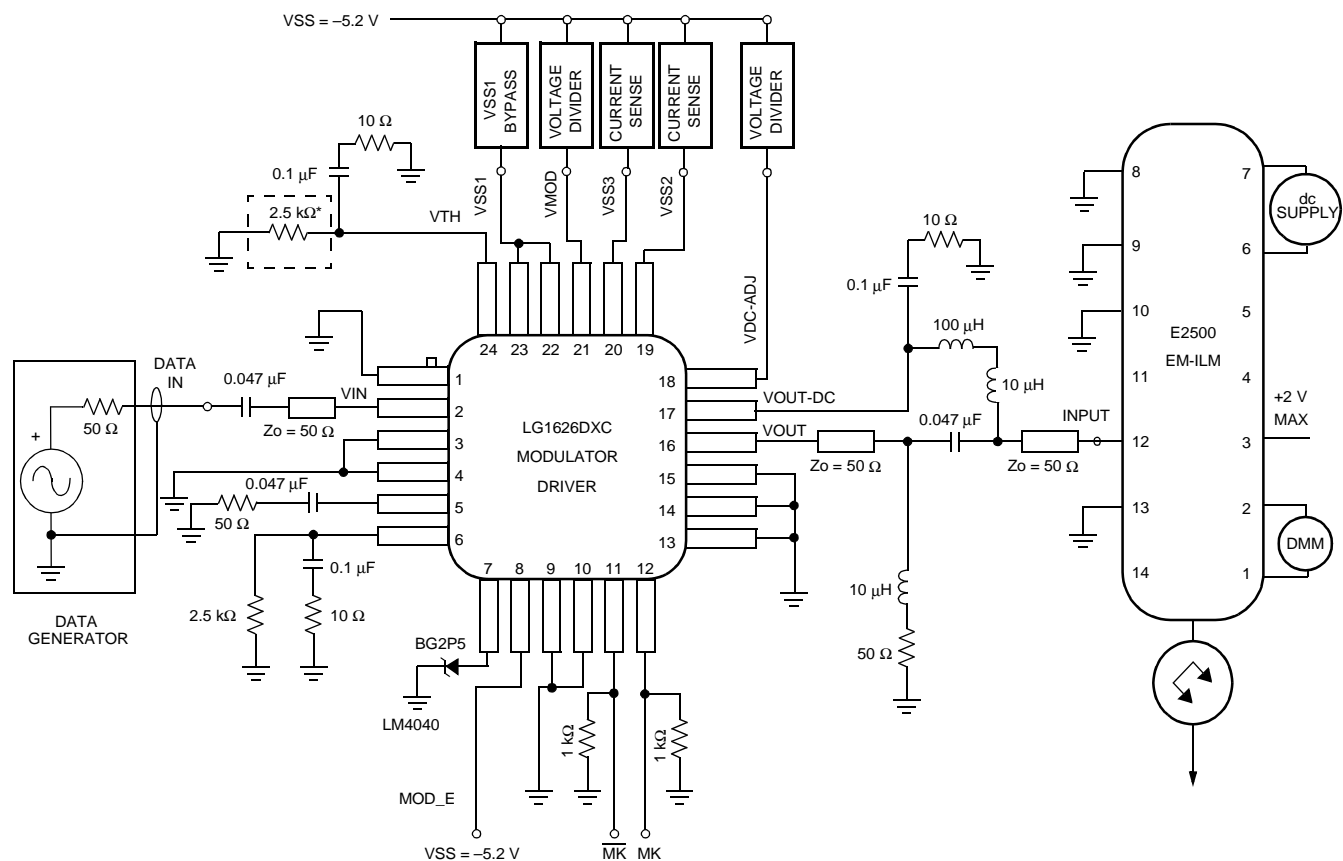

5-6554(F),b

*A 2.5 kΩ resistor will set the eye crossing at 50%. A 5 kΩ potentiometer will allow the eye crossing to be varied.

Notes:

All bypass caps should be mounted close to the package.

ISS3 can be measured and used to control VMOD.

ISS2 can be measured and used to control VOUT-DC.

For optimal performance, the proximity of the two components should be minimized and the package bottom must be soldered to the circuit board (GND).

For proper impedance matching, high-speed transmission lines should be 50 Ω controlled impedance lines.

Figure 5. Typical Optical Evaluation of the LG1626DXC and EM2500 EM-ILM

Electrical Characteristics (continued)

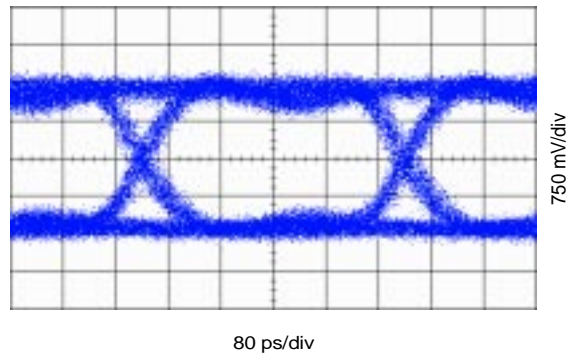

5-7341(F)

Figure 6. Typical Electrical Eye Diagram (ac Coupled to Scope)

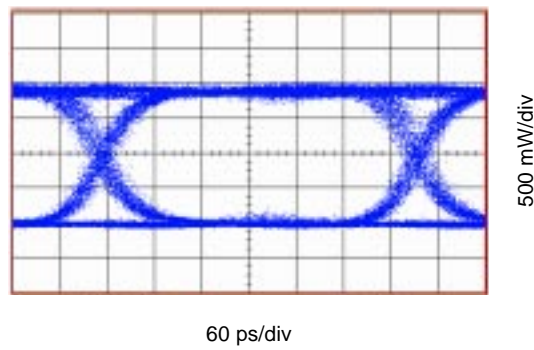

5-7342(F)

Figure 7. Typical Optical Eye Diagram

Table 5. Pin Description of Lucent's E2500 EM-ILM Modulator

Pin	Description
1, 2	Thermistor
3	Laser Anode
4	Monitor Anode
5	Monitor Cathode
6	Thermoelectric Cooler (+)
7	Thermoelectric Cooler (-)
8, 9	Case Ground
10, 14	No Connect
11, 13	Laser/Modulator Ground
12	Modulator Anode (-) 50 Ω RF Input

Outline Diagram

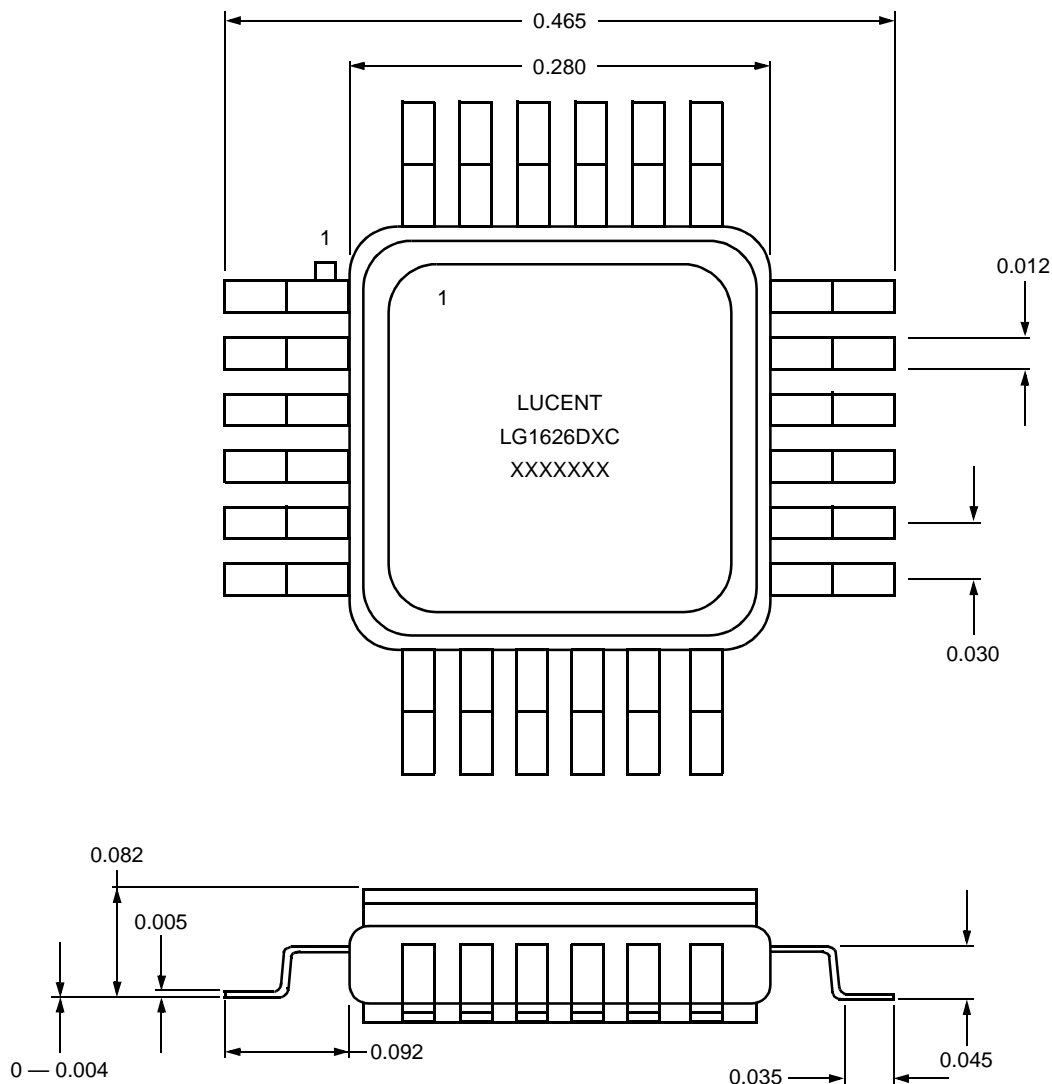

12-3224(F).a

Assembly Notes:

Standoff specifications applies to package prior to solder dipping of leads and package base.

During board assembly use back lighting to silhouette the package. This will eliminate reflection problems with the solder on the bottom of the package.

Lead space tolerance should be set to ± 0.012 in.

Board solder pattern for the package base should not exceed 50% of the package base area.

Insertion pressure should not exceed 125 grams.

LG1626DXC Ordering Information

Device	Type	Comcode Number
LG1626DXC	24-Pin Package	108192865

For additional information, contact your Microelectronics Group Account Manager or the following:

INTERNET: <http://www.lucent.com/micro>

E-MAIL: docmaster@micro.lucent.com

N. AMERICA: Microelectronics Group, Lucent Technologies Inc., 555 Union Boulevard, Room 30L-15P-BA, Allentown, PA 18103

1-800-372-2447, FAX 610-712-4106 (In CANADA: **1-800-553-2448**, FAX 610-712-4106)

ASIA PACIFIC: Microelectronics Group, Lucent Technologies Singapore Pte. Ltd., 77 Science Park Drive, #03-18 Cintech III, Singapore 118256

Tel. (65) 778 8833, FAX (65) 777 7495

CHINA: Microelectronics Group, Lucent Technologies (China) Co., Ltd., A-F2, 23/F, Zao Fong Universe Building, 1800 Zhong Shan Xi Road, Shanghai 200233 P. R. China **Tel. (86) 21 6440 0468, ext. 316**, FAX (86) 21 6440 0652

JAPAN: Microelectronics Group, Lucent Technologies Japan Ltd., 7-18, Higashi-Gotanda 2-chome, Shinagawa-ku, Tokyo 141, Japan

Tel. (81) 3 5421 1600, FAX (81) 3 5421 1700

EUROPE: Data Requests: MICROELECTRONICS GROUP DATALINE: **Tel. (44) 1189 324 299**, FAX (44) 1189 328 148

Technical Inquiries: GERMANY: **(49) 89 95086 0** (Munich), UNITED KINGDOM: **(44) 1344 865 900** (Ascot),

FRANCE: **(33) 1 40 83 68 00** (Paris), SWEDEN: **(46) 8 594 607 00** (Stockholm), FINLAND: **(358) 9 4354 2800** (Helsinki),

ITALY: **(39) 02 6608131** (Milan), SPAIN: **(34) 1 807 1441** (Madrid)

Lucent Technologies Inc. reserves the right to make changes to the product(s) or information contained herein without notice. No liability is assumed as a result of their use or application. No rights under any patent accompany the sale of any such product(s) or information.

