

UTCKSA1625 PNP EPITAXIAL SILICON TRANSISTOR

HIGH VOLTAGE TRANSISTOR

FEATURES

- *Collector-Emitter voltage:
V_{CEO}=-400V
- *Collector Dissipation:
P_c(max)=625mW
- *Low collector-Emitter saturation voltage

APPLICATIONS

- *Telephone switching
- *High voltage switch

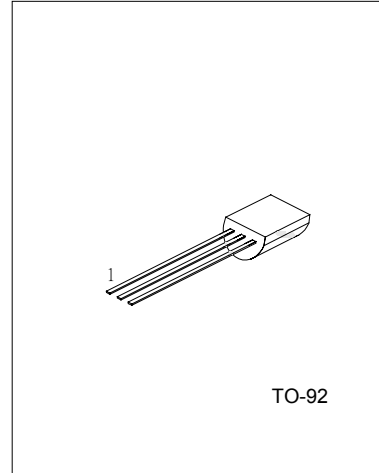

1:EMITTER 2: COLLECTOR 3: BASE

ABSOLUTE MAXIMUM RATINGS (Operating temperature range applies unless otherwise specified)

PARAMETER	SYMBOL	RATINGS	UNIT
Collector-base voltage	V _{CB0}	-400	V
Collector-emitter voltage	V _{CEO}	-400	V
Emitter-base voltage	V _{EBO}	-6	V
Collector dissipation(T _a =25°C)	P _c	625	mW
Collector current	I _c	-300	mA
Junction Temperature	T _j	150	°C
Storage Temperature	T _{STG}	-55 ~ +150	°C

ELECTRICAL CHARACTERISTICS(T_j=25°C, unless otherwise specified)

PARAMETER	SYMBOL	TEST CONDITIONS	MIN	TYP	MAX	UNIT
Collector-base breakdown voltage	BV _{CB0}	I _c =-100μA, I _E =0	-400			V
Collector-emitter breakdown voltage	BV _{CEO}	I _c =-1mA, I _B =0	-400			V
Collector-emitter breakdown voltage	BV _{CES}	I _c =-100μA, V _{BE} =0	-400			V
Emitter-base breakdown voltage	BV _{EBO}	I _E =-100μA, I _c =0	-5			V
Collector cut-off current	I _{CB0}	V _{CB} =-300V, I _E =0			-100	nA
Collector cut-off current	I _{CES}	V _{CB} =-400V, V _{BE} =0			-1	μA
Emitter cut-off current	I _{EBO}	V _{EB} =-4V, I _c =0			100	nA
DC current gain(note)	h _{FE}	V _{CE} =-10V, I _c =-1mA V _{CE} =-10V, I _c =-10mA V _{CE} =-10V, I _c =-50mA V _{CE} =-10V, I _c =-100mA	60 70 70 40		300	
Collector-emitter saturation voltage	V _{CE(sat)}	I _c =-10mA, I _B =-1mA I _c =-50mA, I _B =-5mA			-0.20 -0.5	V
Base-emitter saturation voltage	V _{BE(sat)}	I _c =-10mA, I _B =-1mA			-0.75	V
Output capacitance	C _{ob}	V _{CB} =-20V, I _E =0, f=1MHz			7	pF

Note: Pulse test:PW<300μs, Duty Cycle<2%

UTCKSA1625 PNP EPITAXIAL SILICON TRANSISTOR

TYPICAL PARAMETERS PERFORMANCE

Fig.1 Dc current gain

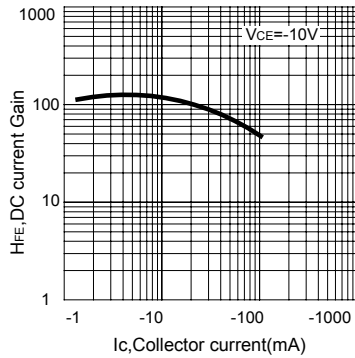

Fig.2 Base-emitter saturation voltage

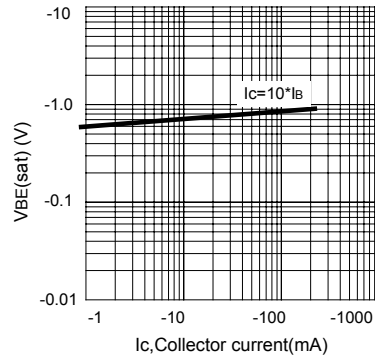

Fig.3 Collector-emitter saturation voltage

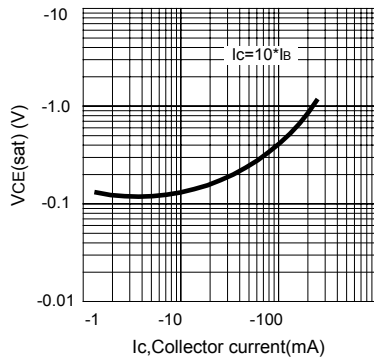
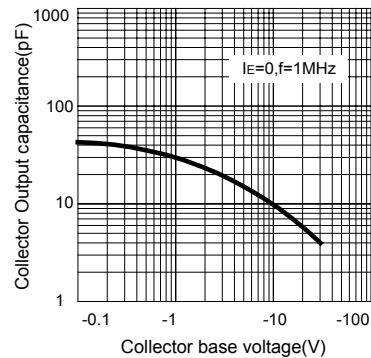

Fig.4 Collector Output capacitance



UTC assumes no responsibility for equipment failures that result from using products at values that exceed, even momentarily, rated values (such as maximum ratings, operating condition ranges, or other parameters) listed in products specifications of any and all UTC products described or contained herein. UTC products are not designed for use in life support appliances, devices or systems where malfunction of these products can be reasonably expected to result in personal injury. Reproduction in whole or in part is prohibited without the prior written consent of the copyright owner. The information presented in this document does not form part of any quotation or contract, is believed to be accurate and reliable and may be changed without notice.