

KS9287

PRELIMINARY

DATA SHEET

1999.6.7

INTRODUCTION

The KS9287 is a Digital Signal Processor for VCD and Hi-Fi CD players. It has enhanced the picture quality of VCD. This IC, when compared to the existing product, has vastly improved its performance in the following areas.

- Frame Sync Detect
- Error Correcting Code Ability
- CLV Performance
- DPLL Capture Range
- EFM Signal Compensation

FEATURES

- EFM data demodulation
- Enhanced Frame sync detection/protection/insertion
- Error Correction (C1: double correction, C2: double correction / quadruple correction)
- Interpolation
- Subcode Data serial output
- Enhanced CLV servo controller
- Enhanced DPLL
- MICOM Interface
- Digital Audio Out
- Built-in 16 K SRAM
- 2x Playback Capability
- 5 V +/- 10% Single Power Supply
- CMOS Process

ORDERING INFORMATION

Device	Package	Operating Temperature
KS9287	80-QFP-1420C	-20 °C ~ +75 °C

BLOCK DIAGRAM

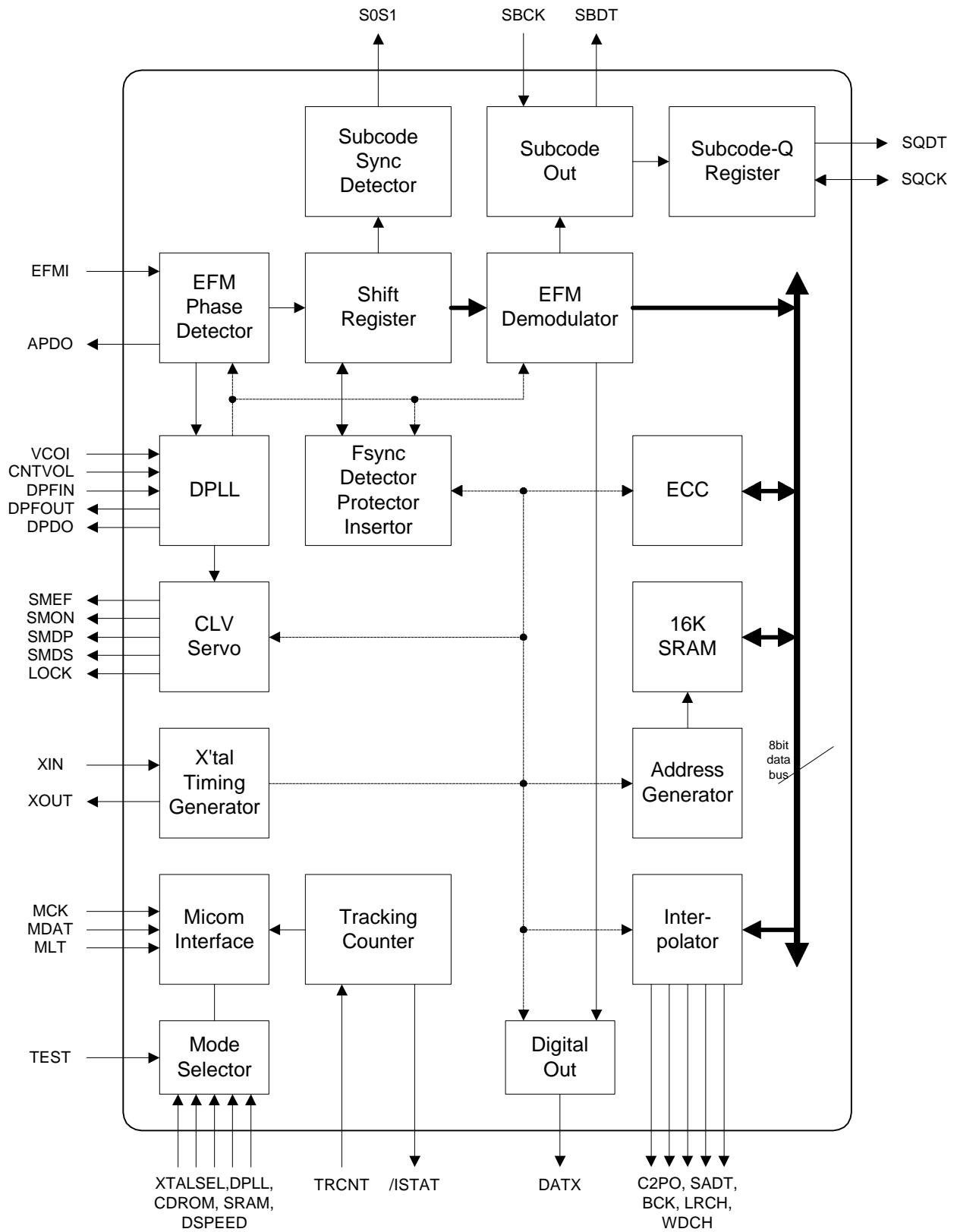

PIN CONFIGURATION

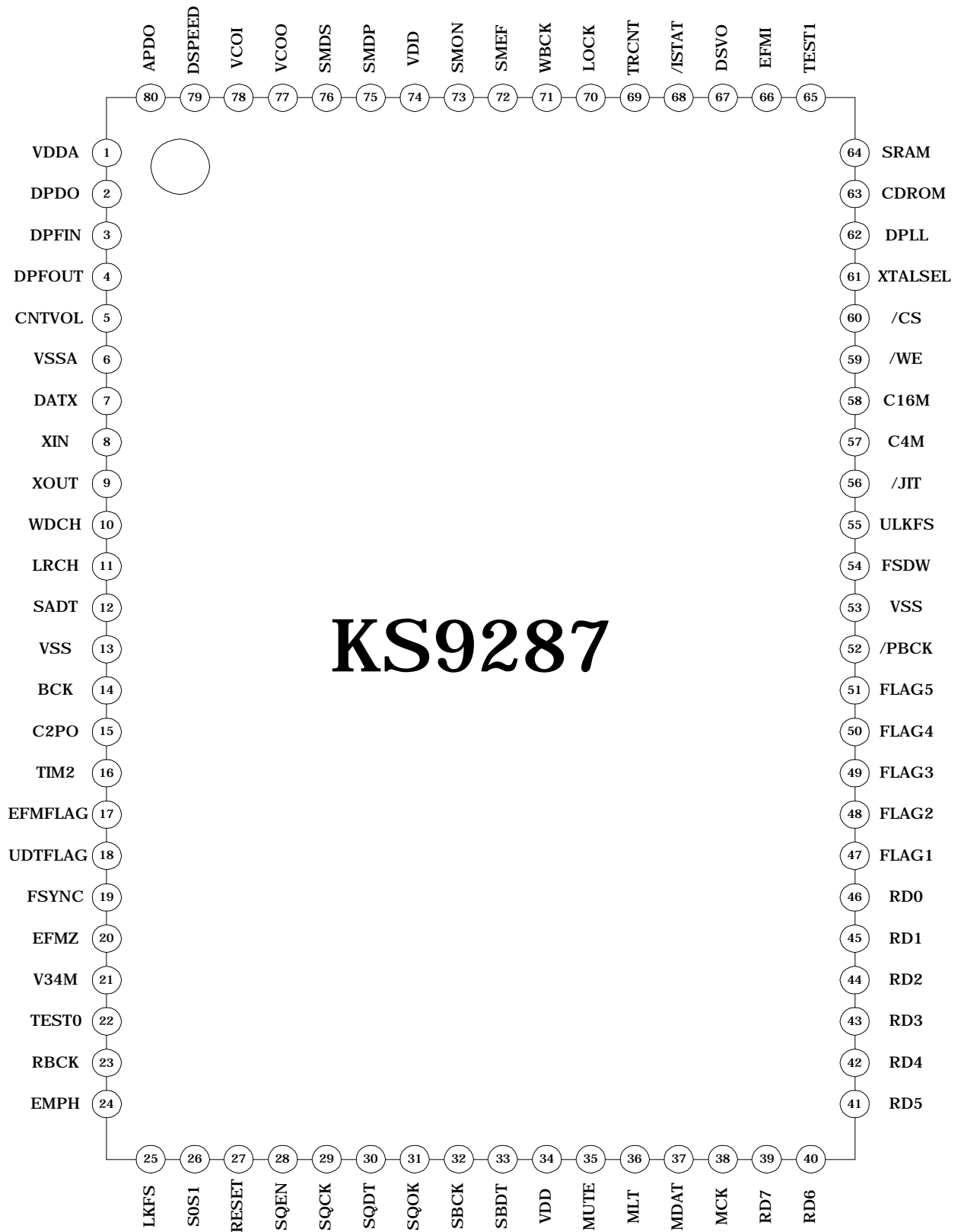

PIN DESCRIPTION

No.	Pin Name	I/O	Description
1	VDDA	-	Analog VDD
2	DPDO	O	Charge pump output for Digital PLL
3	DPFIN	I	Filter input for Digital PLL
4	DPFOUT	O	Filter output for Digital PLL
5	CNTVOL	I	VCO control voltage for Digital PLL
6	VSSA	-	Analog Ground
7	DATX	O	Digital Audio Serial Output
8	XIN	I	X'tal oscillator input
9	XOUT	O	X'tal oscillator output
10	WDCH	O	Word clock output of 48 bits/Slot (88.2 kHz)
11	LRCH	O	Channel clock output of 48 bits/Slot (44.1 kHz)
12	SADT	O	Serial audio data output of 48 bits/Slot (MSB first)
13	VSS	-	Digital Ground
14	BCK	O	Bit clock output of 48 bits/Slot (2.1168 MHz)
15	C2PO	O	C2 Pointer for Serial audio data
16	TIM2	O	Normal or Double speed control output
17	EFMFLAG	O	8 to14 demodulation error flag
18	UDTFLAG	O	Undesiable T Flag (Lower 3T signal in EFM signal)
19	FSYNC	O	Detected Frame Sync
20	EFMZ	O	EFM signal demodulated NRZI
21	V34M	O	Internal VCO clock (34.5744MHz)
22	TEST0	I	Test input (H: Test, L: Normal)
23	RBCK	I	Read base clock
24	EMPH	O	Emphasis output (H: Emphasis On, L: Emphasis Off)
25	LKFS	O	The Lock Status output of frame sync
26	S0S1	O	Output of subcode sync signal (S0+S1)
27	RESET	I	System reset at "L"
28	SQEN	I	SQCK control signal (H: External clock, L: Internal clock)
29	SQCK	I/O	Subcode-Q data bit clock
30	SQDT	O	Serial output of Subcode-Q data
31	SQOK	O	The CRC check result signal output of Subcode-Q
32	SBCK	I	Subcode data bit clock

PIN DESCRIPTION (Continued)

No.	Pin Name	I/O	Description
33	SBDT	O	Subcode data serial output
34	VDD	-	Digital VDD
35	MUTE	I	Mute control input ("H": Mute ON)
36	MLT	I	Latch Signal Input from MICOM
37	MDAT	I	Serial data input from MICOM
38	MCK	I	Serial data transferring clock input from MICOM
39	RD7	I/O	SRAM data I/O port (MSB)
40	RD6	I/O	SRAM data I/O port 6
41	RD5	I/O	SRAM data I/O port 5
42	RD4	I/O	SRAM data I/O port 4
43	RD3	I/O	SRAM data I/O port 3
44	RD2	I/O	SRAM data I/O port 2
45	RD1	I/O	SRAM data I/O port 1
46	RD0	I/O	SRAM data I/O port 0 (LSB)
47	FLAG1	I/O	Monitoring output for ECC (RA0)
48	FLAG2	I/O	Monitoring output for ECC (RA1)
49	FLAG3	I/O	Monitoring output for ECC (RA2)
50	FLAG4	I/O	Monitoring output for ECC (RA3)
51	FLAG5	I/O	Monitoring output for ECC (RA4)
52	/PBCK	I/O	VCO/2 clock output (4.3218 MHz) (RA5)
53	VSS	I/O	Digital ground
54	FSDW	I/O	Frame Sync protection Window (RA6)
55	ULKFS	I/O	Frame sync protection status (RA7)
56	/JIT	I/O	Display of either RAM overflow or underflow for ± 4 frame jitter margin (RA8)
57	C4M	I/O	4.2336 MHz signal output (RA9)
58	C16M	I/O	16.9344 MHz signal output (RA10)
59	/WE	I/O	Write enable signal for external SRAM
60	/CS	I/O	Chip select signal for external SRAM
61	XTALSEL	I	Mode Selection1 (H: 33.8688 MHz, L: 16.9344 MHz)
62	DPLL	I	Mode Selection2 (H: APLL, L: DPLL)
63	CDROM	I	Mode Selection3 (H: CD-ROM, L: CDP)
64	SRAM	I	Mode selection4 (H: External SRAM, L: Internal SRAM)

PIN DESCRIPTION (Continued)

No.	Pin Name	I/O	Description
65	TEST1	I	TEST input terminal (GND connection)
66	EFMI	I	EFM signal input
67	DSVO	O	Digital sum value output
68	/ISTAT	O	The internal status output
69	TRCNT	I	Tracking counter input signal
70	LOCK	O	Output signal of LKFS condition sampled PBFR/16 (if LKFS is "H", LOCK is "H", if LKFS is sampled "L" at least 8 times by PBFR/16, LOCK is "L")
71	WBCK	O	Write frame clock (Lock : 7.35 kHz)
72	SMEF	O	LPF time constant control of the spindle servo error signal
73	SMON	O	ON/OFF control signal for spindle servo
74	VDD	-	Digital VDD
75	SMDP	O	Spindle Motor drive (Rough control in the SPEED mode, Phase control in the PHASE mode)
76	SMDS	O	Spindle Motor drive (Velocity control in the PHASE mode)
77	VCOO	O	VCO output
78	VCOI	I	VCO input (8.6436MHz when locked by WBCK)
79	DSPEED	I	Double speed mode select (H: Normal, L: 2 times)
80	APDO	O	Analog PLL charge pump output

ABSOLUTE MAXIMUM RATINGS

Item	Symbol	Min	Typ	Max	Unit
Supply Voltage	V_{DD}	-0.3	-	7.0	V
Input Voltage	V_I	-0.3	-	7.0	V
Output Voltage	V_O	-0.3	-	7.0	V
Operating Temperature	T_{OPR}	-20	-	75	°C
Storage Temperature	T_{STG}	-40	-	125	°C

ELECTRICAL CHARACTERISTICS

DC Characteristics ($V_{DD} = 5\text{ V}$, $V_{SS} = 0\text{ V}$, $T_a = 25\text{ °C}$)

Item	Symbol	Condition	Min	Typ	Max	Unit	Related pins
'H' Input Voltage1	V_{IH1}	-	$0.7V_{DD}$	-	-	V	All input
'L' Input Voltage1	V_{IL1}	-	-	-	$0.3V_{DD}$	V	
'H' Input Voltage2	V_{IH2}	-	$0.8V_{DD}$	-	-	V	All bi-direction, MLT, MCK, MDT
'L' Input Voltage2	V_{IL2}	-	-	-	$0.2V_{DD}$	V	
'H' Output Voltage1	V_{OH1}	$I_{OH}=-1\text{mA}$	$V_{DD}-0.5$	-	V_{DD}	V	All output pins
'L' Output Voltage1	V_{OL1}	$I_{OL}=1\text{mA}$	0	-	0.4	V	
'H' Output Voltage2	V_{OH2}	$I_{OH}=-1\text{mA}$	$V_{DD}-0.5$	-	V_{DD}	V	All bi-direction
'L' Output Voltage2	V_{OL2}	$I_{OL}=1\text{mA}$	0	-	0.4	V	
'H' Output Voltage3	V_{OH3}	$I_{OH}=-1\text{mA}$	$V_{DD}-0.5$	-	V_{DD}	V	All Tri-state output
'L' Output Voltage3	V_{OL3}	$I_{OL}=1\text{mA}$	0	-	0.4	V	
Input Leakage Current1	I_{LKG1}	$V_I=0\sim V_{DD}$	-5	-	5	μA	All input (except XIN, VCOI)
Input Leakage Current2	I_{LKG2}	$V_I=0\sim V_{DD}$	-10	-	10	μA	XIN, VCOI
Three State Output Leakage Current	I_{OLKG}	$V_O=0\sim V_{DD}$	-5	-	5	μA	SMEF, SMDP, SMDS, APDO, DPDO

AC Characteristics

(1) When pulse is input to XI pin ($V_{DD}=5V$, $V_{SS}=0V$, $T_a=25^\circ C$)

Item	Symbol	Min	Typ	Max	Unit
'H' Level Pulse Width	T_{WH}	13	-	-	ns
'L' Level Pulse Width	T_{WL}	13	-	-	ns
Pulse Frequency	T_{CK}	26	-	-	ns
Input 'H' Level	V_{IH}	$V_{DD}-1.0$	-	-	V
Input 'L' Level	V_{IL}	-	-	0.8	V
Rising & Falling Time	t_R, t_F	-	-	10	ns

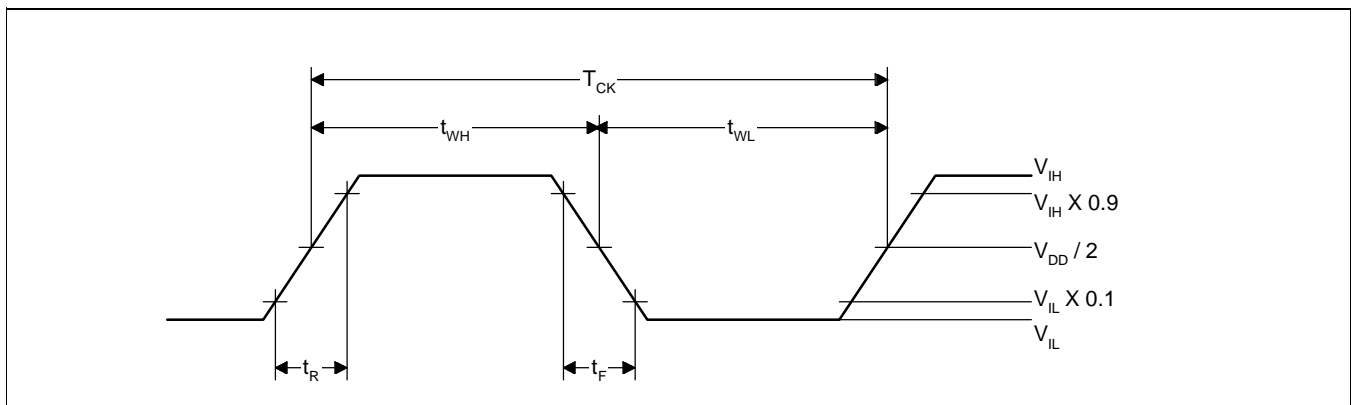

(2) MCK, MDAT, MLT, TRCNT ($V_{DD}=5V$, $V_{SS}=0V$, $T_a=25^\circ C$)

Item	Symbol	Min	Typ	Max	Unit
Clock Frequency	f_{CK1}	-	-	1	MHz
Clock Pulse Width	t_{WCK1}	500	-	-	ns
Setup Time	t_{SU}	300	-	-	ns
Hold Time	t_H	300	-	-	ns
Delay Time	t_D	300	-	-	ns
Latch Pulse Width	t_W	1000	-	-	ns
TRCNT, SQCK Frequency	f_{CK2}	-	-	1	MHz
TRCNT, SQCK Pulse Width	t_{WCK2}	500	-	-	ns

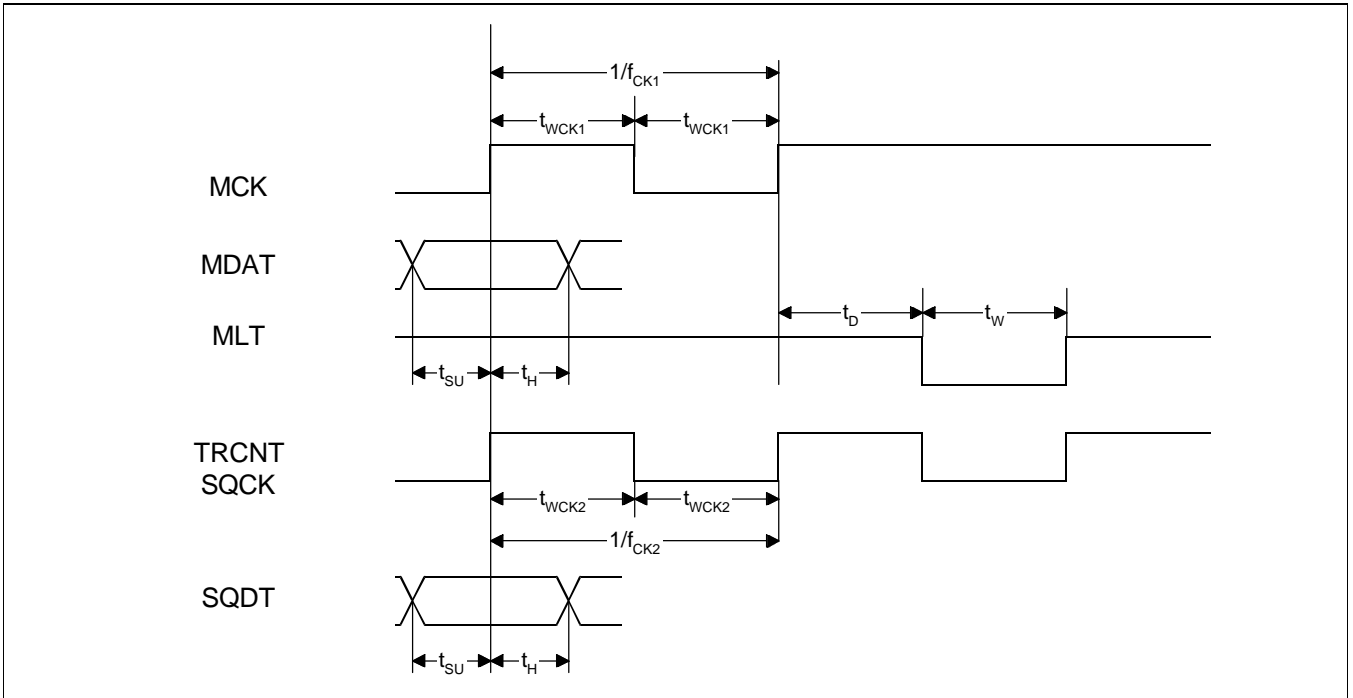

FUNCTIONAL DESCRIPTION

MICOM INTERFACE

Data input from MICOM is received in MDAT, and transmitted by MCK. This signal is stored in the Control Register by MLT. The Timing diagram for this process is shown in Figure 1

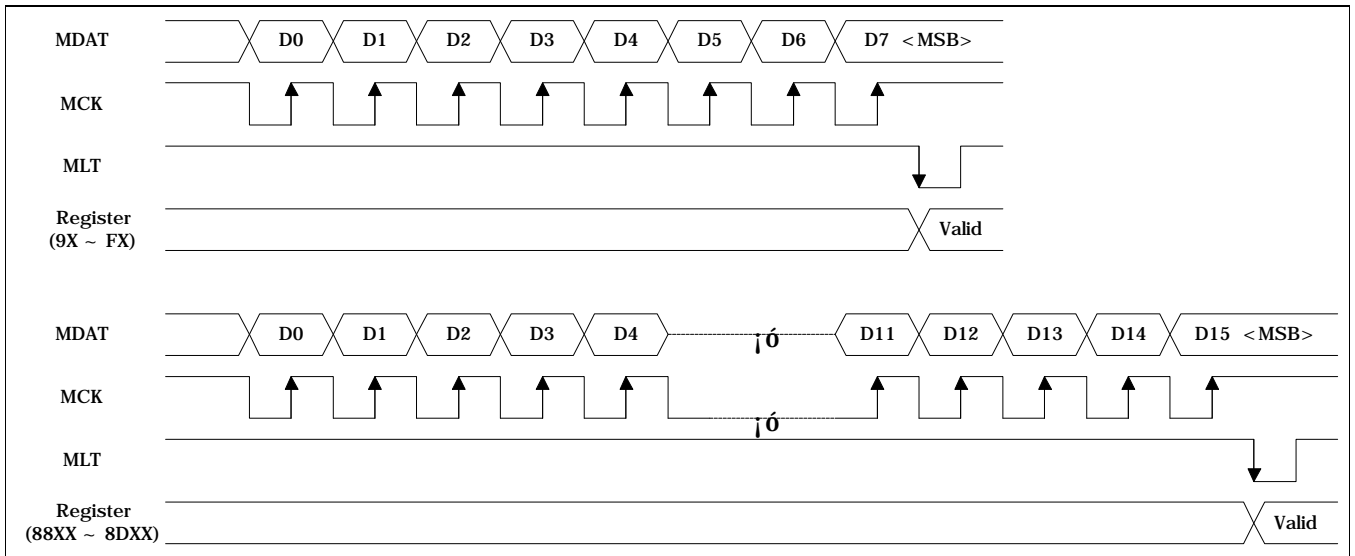

Figure 1. MICOM Data Input Timing Diagram

Table 1. Control Register and Data

Register	Name	Address D7~D4	Data				/ISTAT Pin
			D3	D2	D1	D0	
CNTL-Z	Data control	1001 (9X)	ZCMT	HIPD	NCLV	CRCQ	HI-Z
CNTL-S	Frame sync protect, attenuation control	1010 (AX)	FSEM	FSEL	WSEL	ATTM	HI-Z
CNTL-L	Tracking counter (lower)	1011 (BX)	TRC3	TRC2	TRC1	TRC0	/complete
CNTL-U	Tracking counter (upper)	1100 (CX)	TRC7	TRC6	TRC5	TRC4	/count
CNTL-W	CLV control	1101 (DX)	-	WB	WP	GAIN	HI-Z
CNTL-C	CLV-mode	1110 (EX)	CLV MODE				/(Pw ≥ 64)
CNTL-D	Double-speed	1111 (FX)	-	-	DS1	DS2	HI-Z

Register	Name	Address D11~D8	Data								/ISTAT Pin
			D7	D6	D5	D4	D3	D2	D1	D0	
CNTL-F	Function control	10001000 (88X)	CDROM	IIS	-	ERA OFF	C1PNT	SADT SW	WDCH SEL1	WDCH SEL0	HI-Z
CNTL-T	EFM Signal control	10001011 (8BX)	VCON	-	-	-	-	-	VSEL	DSV INV	HI-Z
CNTL-E	Frame Sync detection control	10001100 (8CX)	RBSEL	FWSEL	FSMD1	FSMD0	-	-	-	-	HI-Z
CNTL-H	DPLL, monitor pin control	10001101 (8DX)	RES8	-	-	-	DUMB3	DUMB2	DUMB1	DUMB0	HI-Z

Detail Description of Control Register

1. CNTL-Z (\$9X)

This register carries out the following functions: audios zero cross mute, phase pin control, phase servos control signal management, and the decision whether or not to include SQOK data in SQDT.

Bit	3	2	1	0
Identifier	ZCMT	HIPD	NCLV	CRCQ

ZCMT Zero cross mute

0	Zero cross mute is OFF
1	Zero cross mute is ON

HIPD Phase pin control

0	Phase operates normally
1	Phase goes from low to Hi-Z by LKFS

NCLV Phase servos control

0	Phase Servo controlled by Frame Sync
1	Phase Servo controlled by Base Counter

CRCQ

0	SQDT output not including SQOK
1	SQDT = SQOK, when SOS1 is 'H'.

2. CNTL-S (\$AX)

This register sets the frame sync protection and attenuation. FWSEL of CNTL-D is added to define window size. .

Bit	3	2	1	0
Identifier	FSEM	FSEL	WSEL	ATTM

FSEM, FSEL Frame sync protection

0	0	2
0	1	4
1	0	8
1	1	13

FWSEL, WSEL Frame Sync protection window size

0	0	+/- 3T
0	1	+/- 7T
1	0	+/- 13T
1	1	+/- 26T

ATTM, MUTE Control the Frame Sync attenuation

0	0	0 dB
0	1	- ∞ dB
1	0	-12 dB
1	1	-12 dB

3. CNTL-L, U (\$BX, \$CX)

When the number of tracks to be counted is input from MICOM, the CNTL-L, or CNTL-U register loads the data into the tracking counter. This tracking counter is used for improving track jump characteristics.

When the number of tracks to be jumped is input from MICOM, the track number is loaded from MLT's positive edge to the register. If CNTL-L is selected, /COMPLETE signal is output to the /ISTAT pin, and if CNTL-U is selected, /COUNT signal is output. The Timing Diagrams of the tracking counters are Figure-2 and Figure-3.

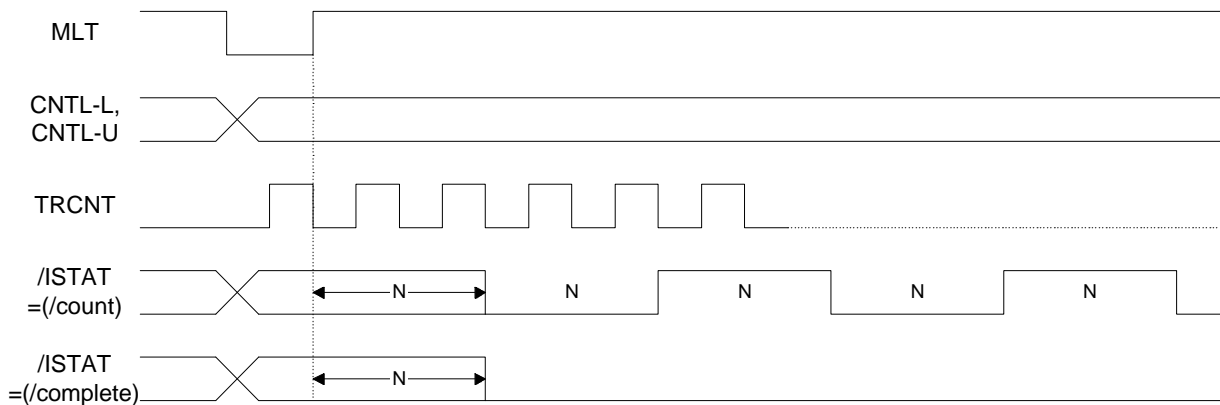

Figure 2. Tracking Counter Timing Diagram

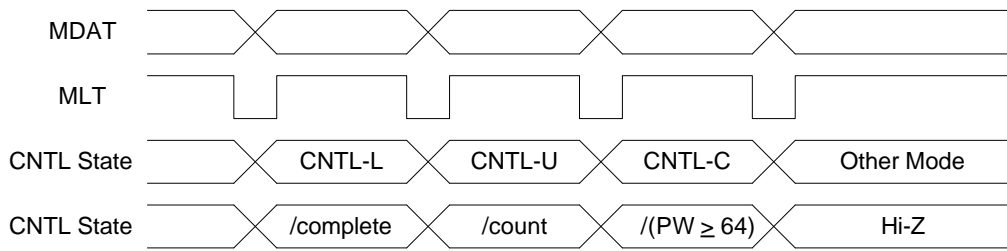

Figure 3. /ISTAT Output Signal According to the CNTL Register

4. CNTL-W (\$DX)

This register sets the CLV-Servos control period and gain..

Bit	3	2	1	0
Identifier	-	WB	WP	GAIN

WB Bottom Hold period control in Speed-Mode

0	XTFT/32
1	XTFR/16

WP Peak Hold period control in Speed-Mode

0	XTFR/4
1	XTFR/2

GAIN SMDS Gain control in Speed-Mode

0	- 12 dB
1	0 dB

5. CNTL-C (\$EX)

This register sets the CLV-Servos operating Mode.

Bit	3	2	1	0
Identifier	CM3	CM2	CM1	CM0

CM3 ~ CM0 Operating Mode control

1	0	0	0	Forward
1	0	1	0	Reverse
1	1	1	0	Speed
1	1	1	1	Phase
0	1	1	0	XPHSP
0	0	0	0	Stop

6. CNTL-D (\$FX)

This register sets the normal speed and double speed mode..

Bit	3	2	1	0
Identifier	-	-	DS1	DS0

DS1, DS0 Speed control

0	0	Normal Speed
1	1	Double Speed (2X)

7. CNTL-F (\$88XX)

This register sets the ECC, Interpolation, communication protocol control mode.

Bit	7	6	5	4	3	2	1	0
Identifier	CDROM	-	-	ERA OFF	C1PNT	SADT SW	WDCH SEL1	WDCH SEL0

CDROM Set the interpolation function On/Off

0	CD-DA mode (Interpolation ON)
1	CD-ROM mode (Interpolation OFF)

ERAOFF Set the Erasure Correcting Feature while in Error Correcting Mode.

0	Erasure Correction On
1	Erasure Correction Off

C1PNT Set the C1 Flag Information after the C1 error correction .

0	C1 flag set
1	C1 flag reset

SADTSW Set the Data communication protocol.

0	48 bits/slot mode
1	64 bits/slot mode

WDCHSEL1, WDCHSEL0

Set the WDCH clock mode.

0	88.2KHz
1	176.4KHz

8. CNTL-M (\$8AXX)

This register sets the frequency error equation in CLV-P mode

Bit	7	6	5	4	3	2	1	0
Identifier	CLVSW	-	-	-	-	-	-	-

CLVSW Set the frequency error equation

0	$((t_{HW} - 279t) + 1) * 32$
1	$(t_{HW} - 560t) * 32$

8. CNTL-T (\$8BXX)

This register sets the EFM Function control mode.

Bit	7	6	5	4	3	2	1	0
Identifier	VCON	-	-	-	-	-	VSEL	DSVINV

VCON Set the EFM signal compensation function mode.

0	Compensation OFF
1	Compensation ON

VSEL Select the EFM signal latch clock.

0	4.3218MHz
1	8.6436MHz

DSVINV Set the DSV inversion output .

0	DSV
1	DSV inverted

9. CNTL-E (\$8CXX)

This register is used for setting the RBCK output and Frame Sync protection window size.

Bit	7	6	5	4	3	2	1	0
Identifier	RBSEL	FWSEL	FSMD1	FSMD0	-	-	-	-

RBSEL Set the RBCK output

0	RBCK/4
1	RBCK

FWSEL, WSEL

Frame Sync protection window size (Refer to WSEL of CNTL-S register)

0	0	+/- 3T
0	1	+/- 7T
1	0	+/- 13T
1	1	+/- 26T

FSMD1, FSMD0

Set the Frame Sync Detection mode

0	0	Pattern mode detect
0	1	Period mode detect
1	0	Compensation mode detect
1	1	Mixed mode detect (only 22T)

12. CNTL-H (\$8DXX)

This register sets the Digital PLLs Processing Mode and Monitoring pin output Mode.

Bit	7	6	5	4	3	2	1	0
Identifier	RES8	-	-	-	DUMB3	DUMB2	DUMB1	DUMB0

RES8 PLCK Resolution when 2X speed

0	PLCK = VCO * 6
1	PLCK = VCO * 8

DUMB3, DUMB2, DUMB1, DUMB0

Set the Monitoring Pin Output Mode

0	Monitoring pin output disable
1	Monitoring pin output enable

- DUMB3 : DSVO, APDO

- DUMB2 : C4M

- DUMB1 : C16M

- DUMB0 : EFMFLAG, UDTFLAG, EFMZ, V34M, FSYNC, FLAG5 ~ FLAG1, /PBCK, FSDW,
ULKFS, /JIT

EFM DEMODULATION

The EFM block is composed of the following parts: EFM demodulator to demodulate the EFM signal read from the disc, EFM phase detector, and the control signal generator.

1) EFM Phase Detector

The EFM signal input from the Disc includes 2.1609 MHz components. To detect the phase of this signal, a Bit Clock (/PBCK) of 4.3218 MHz is used. PBCK detects the phase of the EFM signals Edge, and sends the results to the APD0 pin.

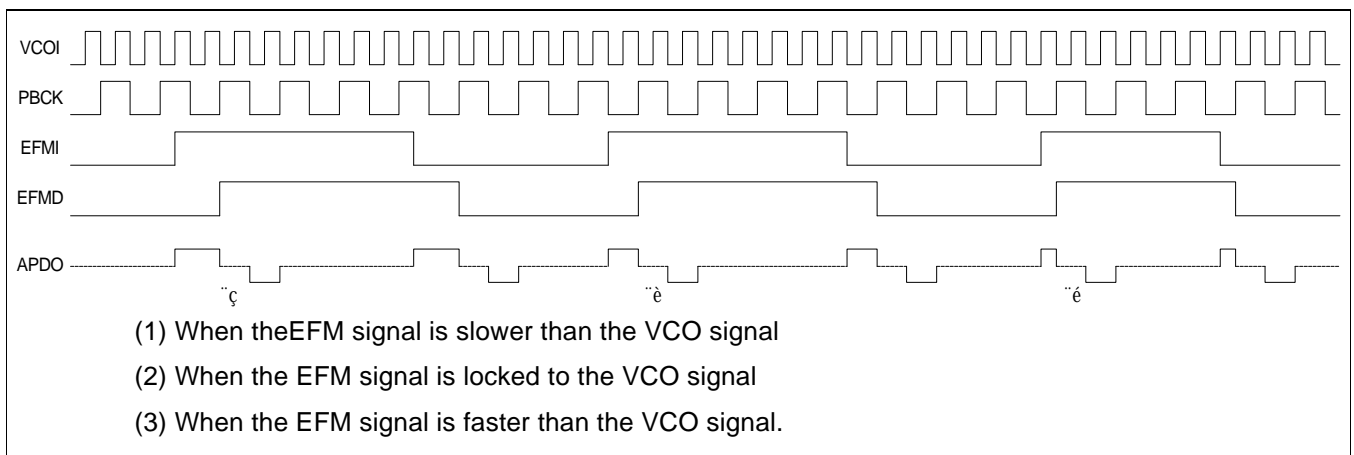

Figure 4. EFM Phase Detector Timing Diagram

2) EFM Demodulation

The modulated 14 channel bit data is demodulated into 8-bit data. There are two types of demodulated data: subcode data and audio data. Subcode data is input into the subcode handling block, and the audio data is stored in the internal SRAM, and its errors are corrected.

3) Frame Sync Detect/Protect/Insert

•Frame Sync Detect

Data is composed of units of frame, and a frame is composed of frame sync, subcode data, audio data, and redundancy data. This IC detects frame sync to maintain synchronization, and there are three detection methods (refer to CNTL-E Command):

- (1) Pattern Detect Method
- (2) Period Detect Method
- (3) Compensation Detect Method: Combination of the methods above

•Frame Sync Protect/Insert

There are some cases in which frame sync is not detected, or detected it from other data which does not include frame sync, due to disc error or jitter. In these cases, the frame sync must be protected and inserted.

To protect frame sync, a window is made by WSEL of the CNTL-S register. The frame sync entering this window is considered valid data, and the frame sync which leaves this window is ignored. If frame sync is not detected within the frame sync protect window, insert instead the frame sync made in the internal counter. If frame sync is inserted continuously, reaching the number of frames set by FSEM and FSEL of the CNTL-S register, the following occurs: ULKFS becomes H, the frame sync protect window is ignored, and the frame sync detected next is accepted unconditionally. When a frame sync is accepted, the ULKFS signal becomes L, and accepts the frame sync detected within the window (refer to below Table).

LKFS	ULKFS	Comment
1	1	Play back frame sync and the generated sync coincide.
0	1	1) The play back frame sync and the generated frame sync do not coincide, but PBFR sync is detected from within the window selected by WEL. 2) PBFR sync and XTFR sync do not coincide, and are not detected from within the window selected by WSEL. Sync insert is carried out.
0	0	1) Immediately after the following situation: Frame sync is not detected within the window, so frame is inserted in the amount set by CNTL-S registers FSEM and FSEL. 2) If PBFR sync is still undetected after 1).

ECC

When disc data is damaged, it is corrected using the ECC (Error Correcting Code) block. It uses the CIRC (Cross Interleaved Reed-Solomon Code), correcting up to 2 errors when C1(32, 28), and up to 4 erasures when C2(28, 24). Error correction handles the data in units of 8-bit 1 symbol.

The ECC block has Pointer handling function, and can generate a C1 pointer in C1 correction, and a C2 pointer in the C2 correction. The C1 and C2 pointers output a flag about the ECC-handled data to mark it as error data. This Flag information signal is input into the interpolator, and used for handling the error data. Also, the Error correcting results can be monitored using the FALF5 ~ FLAG1 pins.

Table 2. Error Correction Monitoring Flag Results

Mode	FLAG5	FLAG4	FLAG3	FLAG2	FLAG1	Remark
C1 No error	0	0	0	0	0	C1 Correction start
C1 1 error Correction	0	0	0	0	1	-
C1 2 error Correction	0	0	0	1	0	-
C1 No Correction	0	1	1	1	1	C1 flag set
C2 No error	1	0	0	0	0	C2 Correction start
C2 1 error Correction	1	0	0	0	1	-
C2 2 error Correction	1	0	0	1	0	-
C2 3 error Correction	1	0	0	1	1	-
C2 4 error Correction	1	0	1	0	0	-
C2 No Correction	1	1	1	1	0	C1 flag copy
C2 No Correction	1	1	1	1	1	C2 flag set

Note: When carrying out forward or backward fast search, MICOM must give the Attenuation, or the MUTE command to the DSP IC. If not, an error can occur when carrying out erasure correction during fast search.

CLV SERVO

CNTL-C, E, G1, G2, and G3 registers are selected to control the CLV (Constant Linear Velocity) servo using the data input from MICOM. Also, the design is such that the servo control is stable when setting the speed. When setting the speed, the $\overline{PW\geq 64}$ signal can be detected from the $\overline{I}STAT$ pin only if the CNTL-D register is first set before the CNTL-C register is selected.

1) Forward

This mode rotates the spindle motor in the forward direction. The related output pin status are as follows.

SMDP	SMDS	SMEF	SMON
H	Hi-Z	L	H

2) Reverse

This mode rotates the spindle motor in the reverse direction. The related output pin status are as follows.

SMDP	SMDS	SMEF	SMON
L	Hi-Z	L	H

3) Speed-mode

This mode is used for rough control of the spindle motor when the track jump or EFM phase is unlocked. If one period of VCO is T , the pulse width of the frame sync is $22T$. There are some cases in which the signal detected in the EFM signal is larger than $22T$ because of disc noise. If you do not eliminate this signal, the correct frame sync cannot be detected. In that case, the EFM signals pulse width is detected using the period of the peak hold clock $RBCK/2$ or $RBCK/4$. Also, detect the EFM signals pulse width using the period of the bottom hold clock $RBCK/16$ or $RBCK/32$.

SMDP	SMDS	SMEF	SMON
H: Accelerate L: Decelerate Hi-Z: Maintain	Hi-Z	L	H

5) Phase-Mode

This mode controls the EFM phase. It detects and outputs to the SMDP pin, the $WBCK/4$ and $RBCK$ s phase difference, when in CLV Normal Control mode and when CNTL-Z registers NCLV is 'L' (refer to Figure-5). If $VCO/2s$ signal period is T , the amount of time during which $WBCK$ is 'H' is called t_{HW} , and $FRSLP$ is '0', 'H' is output from $WBCK$ s negative edge to the SMDS pin during $(t_{HW} - 279T) + 1 \times 32$ or $(t_{HW} - 560T) \times 32$ and 'L' is output until the next $WBCK$ s negative edge (refer to Figure 5).

SMDP	SMDS	SMEF	SMON
H: Accelerate L: Decelerate Hi-Z: Maintain	H/L	L	H

6) Stop

This mode stops the spindle motor.

SMDP	SMDS	SMEF	SMON
L	Hi-Z	L	L

1) SPEED mode

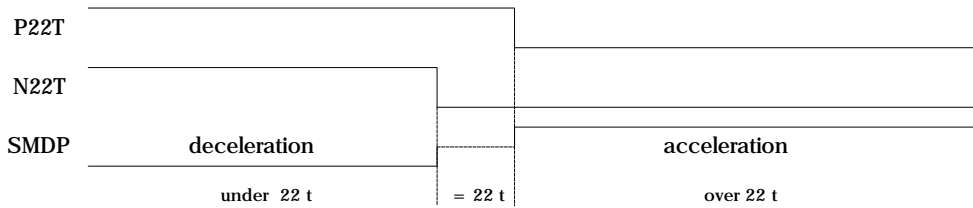

2) PHASE mode

- Phase Error Signal

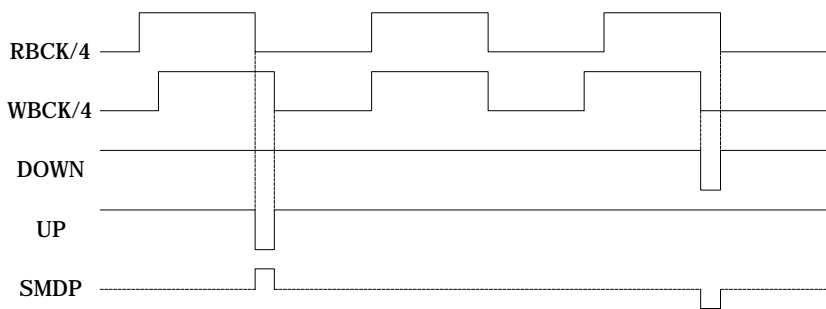

- Frequency Error Signal

$CLV_SW = 0 : \text{Frequency Error Signal} = (t_{HW} - 279 t) + 1 * 32$

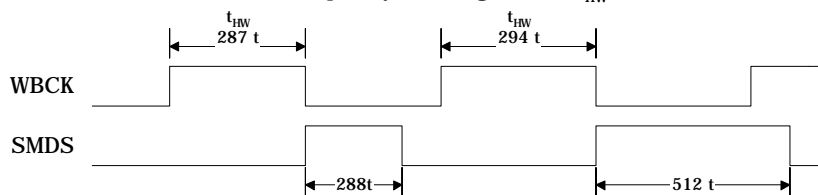

$CLV_SW = 1 : \text{Frequency Error Signal} = (t_{HW} - 560 t) * 36$

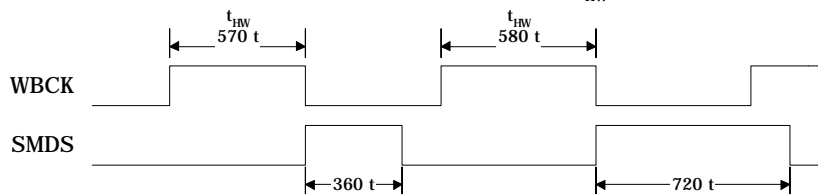

Figure 5. SMDS, SMDP Output Timing Diagram in Normal Control Mode

SUBCODE

The subcode sync signals S0 and S1 are detected in the Subcode sync block. S1 is detected one frame after S0 is detected. At this time, S0+S1 signal is output to the S0S1 pin, and when the S0S1 signal is H, the S0S1 signal is output to the SDAT pin. Out of the data input into the EFMI pin, the 14-bit subcode data is EFM demodulated to 8-bit (P, Q, R, S, T, U, V, W) subcode data, synchronized with the WBCK signal, and output to SDAT by the SBCK clock. Out of the 8 subcode data, only Q data is stored in the 80 shift registers by the WBCK signal. If the CRC result is error, L is output to the SQCK pin, and if not, H is output. If the CNTL-Z registers CRCQ is H, the CRC result is output to the SQDT pin from when the S0 and S1 are H to SQCKs negative edge. The Subcode blocks timing diagram is as follows:

1) The Timing Relation of SQCK, SQDT and S0S1 when SQEN=H

* If subcode-Q datas CRCQ is H, the SQOK signal is output to SQDT according to the SQCK, and if CRCQ is L, the SQOK signal is not output to SQDT..

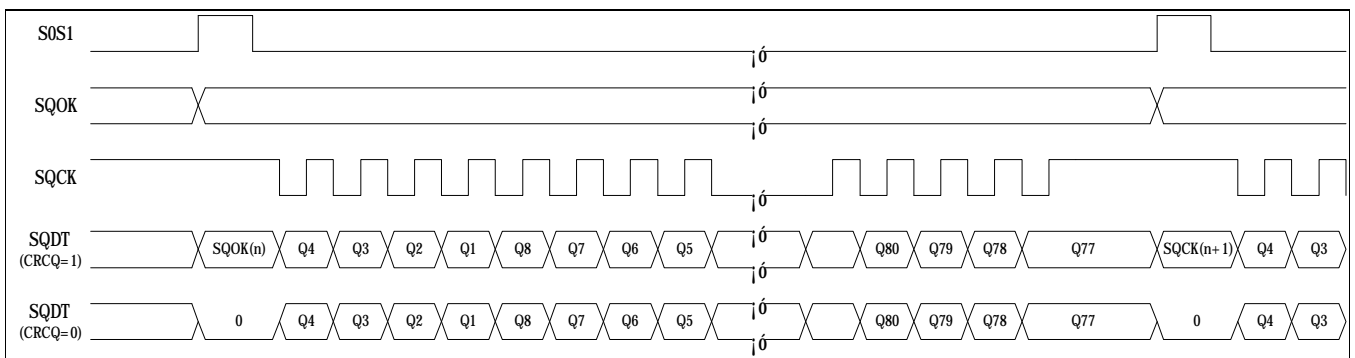

Figure 6. Subcode-Q Timing Diagram 1

2) The Timing Relation of SQCK, SQDT, and S0S1 when SQEN=H

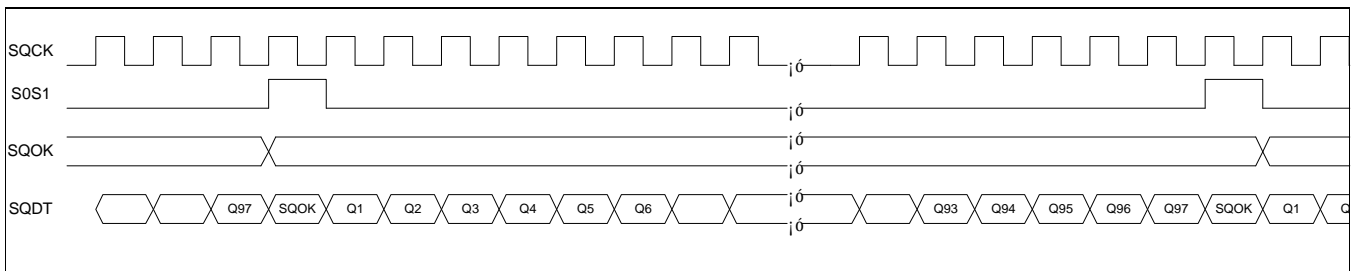

Figure 7. Subcode-Q Timing Diagram 2

3) Timing Relation of SDAT and SBCK

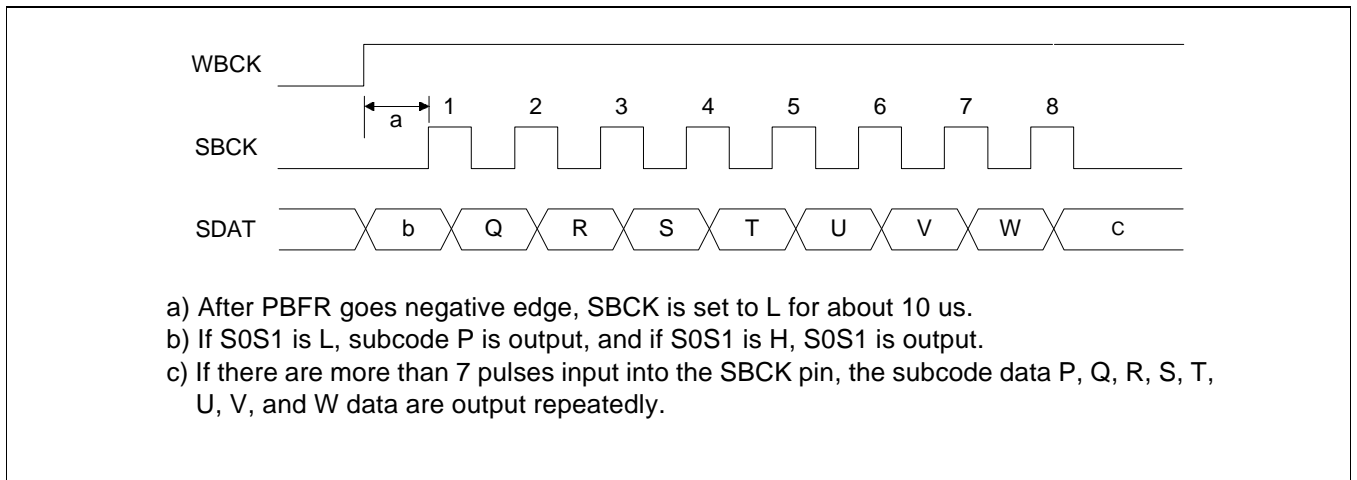

Figure 8. Subcode-Q Data Output Timing Diagram 3

INTERPOLATION / MUTE

Interpolator

If a burst error occurs on the disc, sometimes data cannot be corrected even if you carry out the ECC process. The Interpolator block uses the ECCs C2 pointer to interpolate the data.

The audio data is input into the Data bus in the following order: for each L/R-ch: 8-bit C2 point, lower data 8-bit, and upper data 8-bit.

If C2P0 pin is H, and one error has occurred, the average value interpolation is carried out, and if 3 consecutive errors occurred, the previous value hold interpolation is carried out.

For one period of LRCH, if LRCH is L, R-ch data is output, and if H, L-ch data is output. Please refer to Figure 7 for the Interpolator blocks Timing Chart.

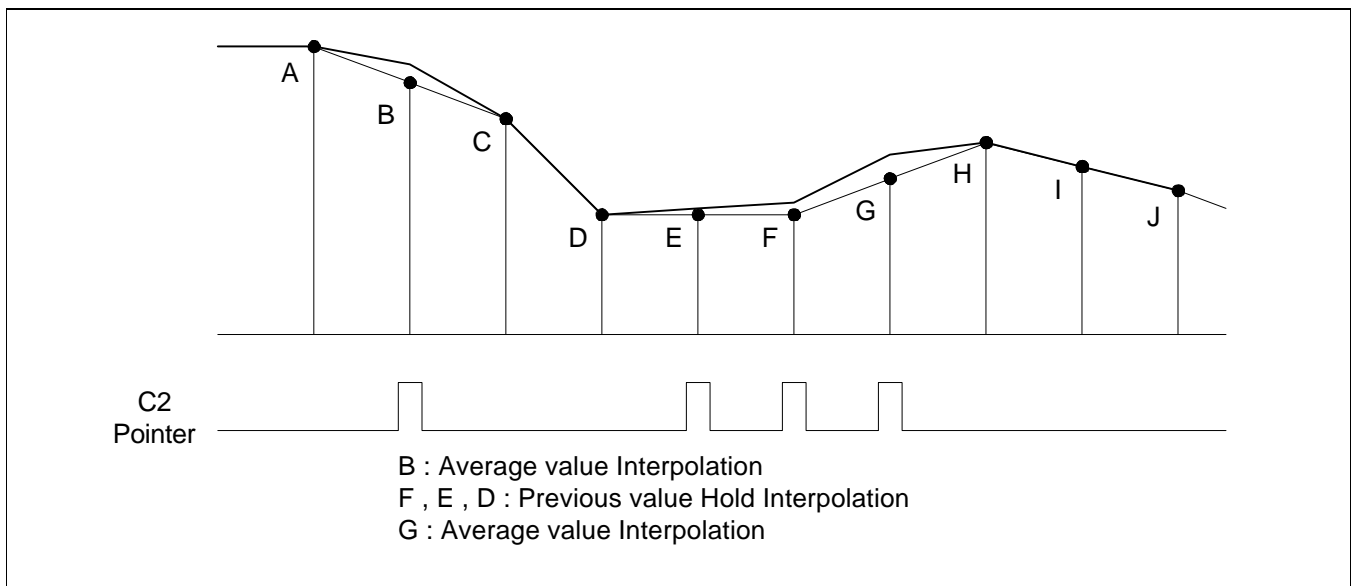

Figure 9. Interpolation Method

Mute/Attenuation

The audio data can be muted or weakened by the ATTM signal of the MUTE pin and CNTL-S register.

- Zero Cross Mute

The audio data is muted when the CNTL-Z registers ZCMT is H, mute is H, and the upper 6 bits of audio data are all H.

- Muting

The audio data is in Muting is the CNTL-Z registers ZCMT is L and the Mute pin is H.

- Attenuation

Audio signal is weakened by the CNTL-Z registers ATTM and Mute signal.

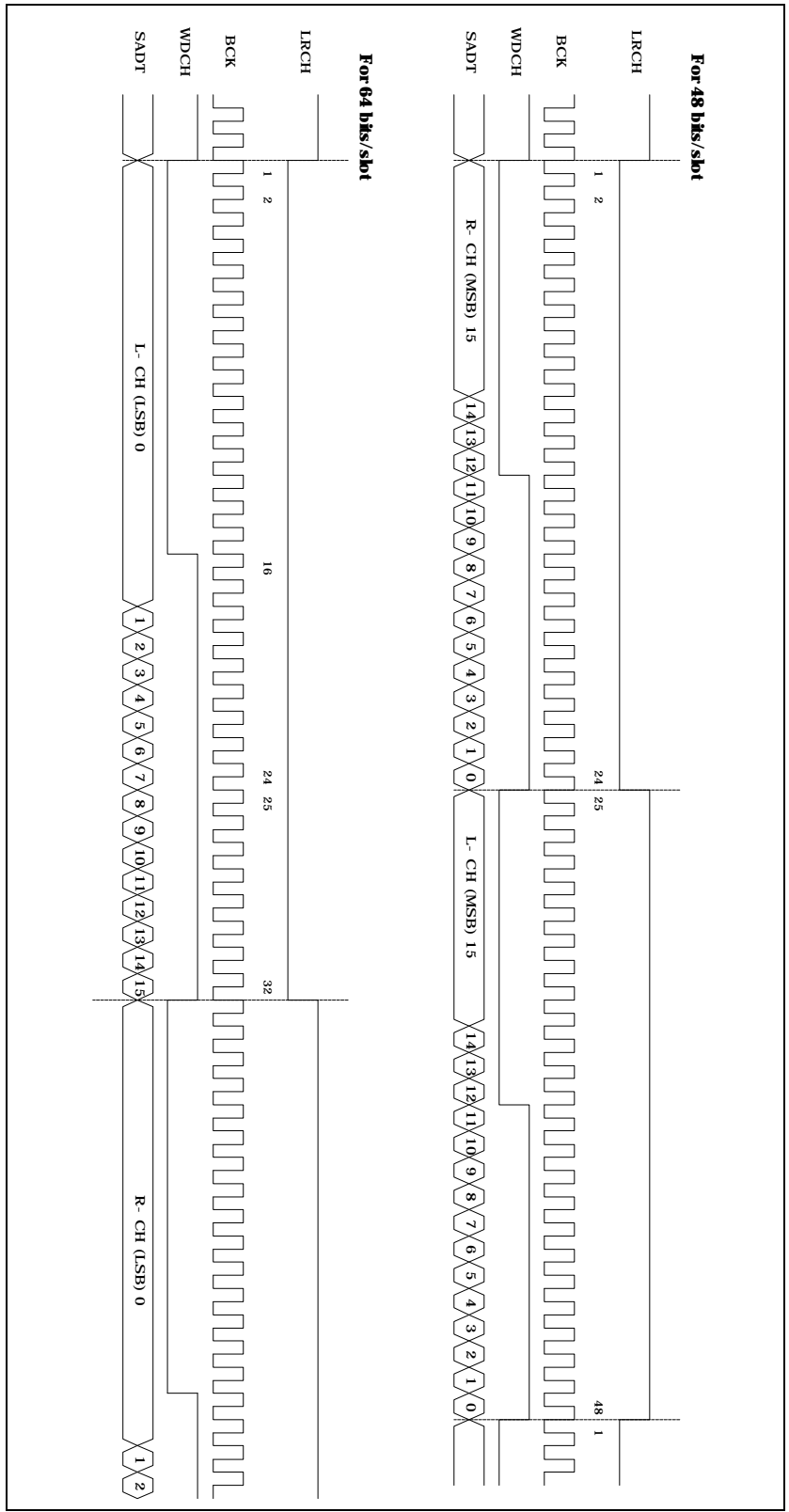

Figure 10. Serial Audio Data Output Timing Diagram

DIGITAL AUDIO OUT

This block serially outputs 2 channel and 16-bit data with the digital audio interface format as reference.

1) Digital audio interface format for CD

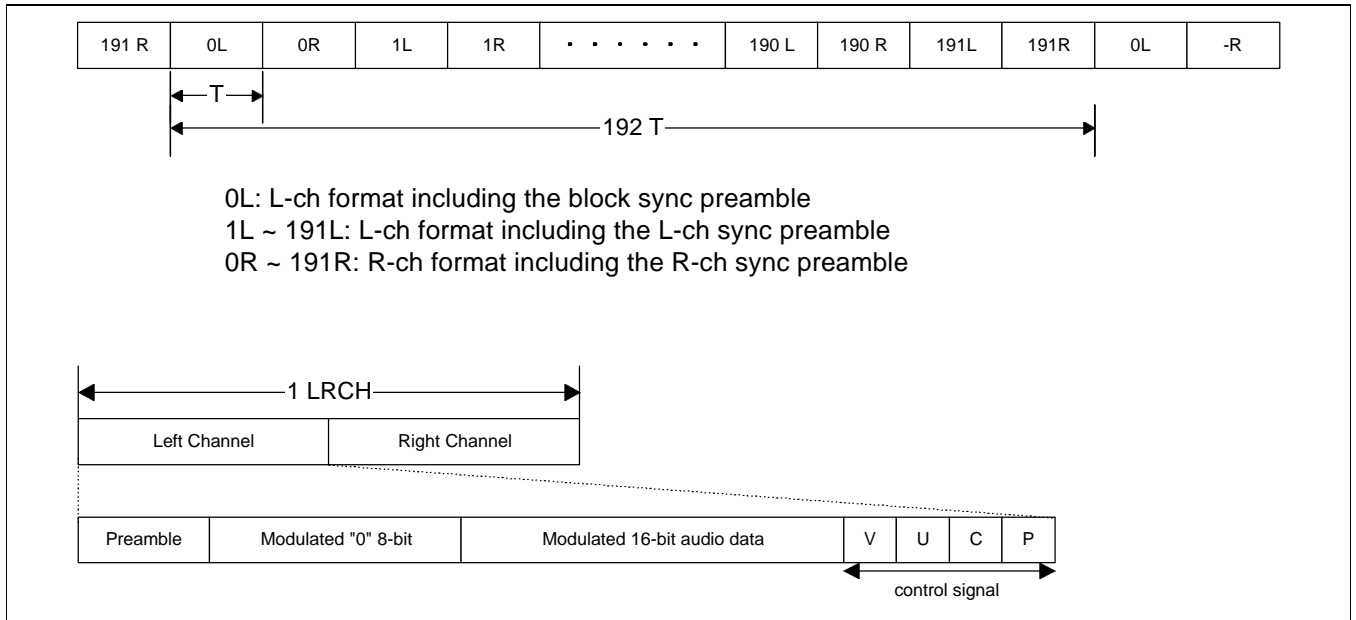

Figure 11. Digital Audio Out Format

•Preamble

The Preamble is used to distinguish the datas block and L/R ch data

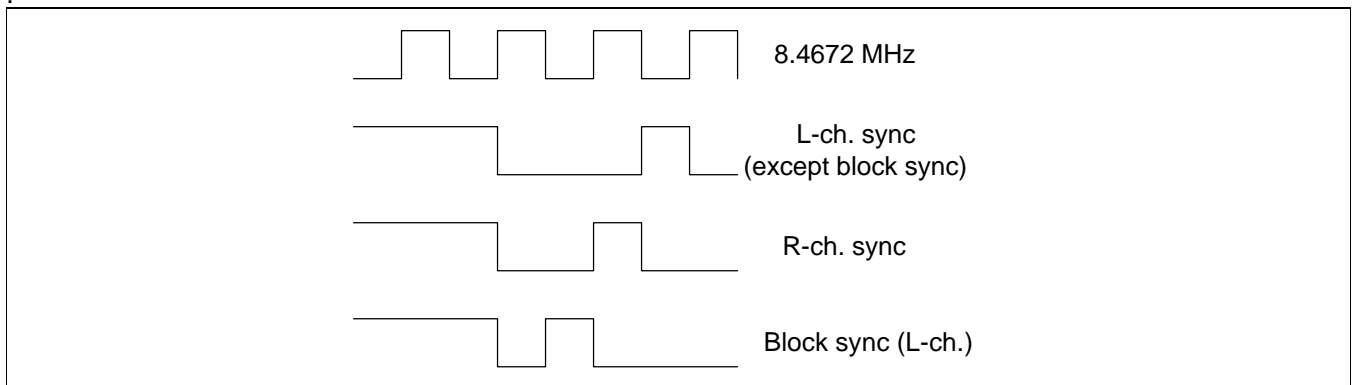

Figure 12. Preamble Signal

•Control Signal

- (1) Validity bit: shows the presence of error in 16-bit audio data: 'H'=error, 'L'=valid data
- (2) User definable bit: subcode data out

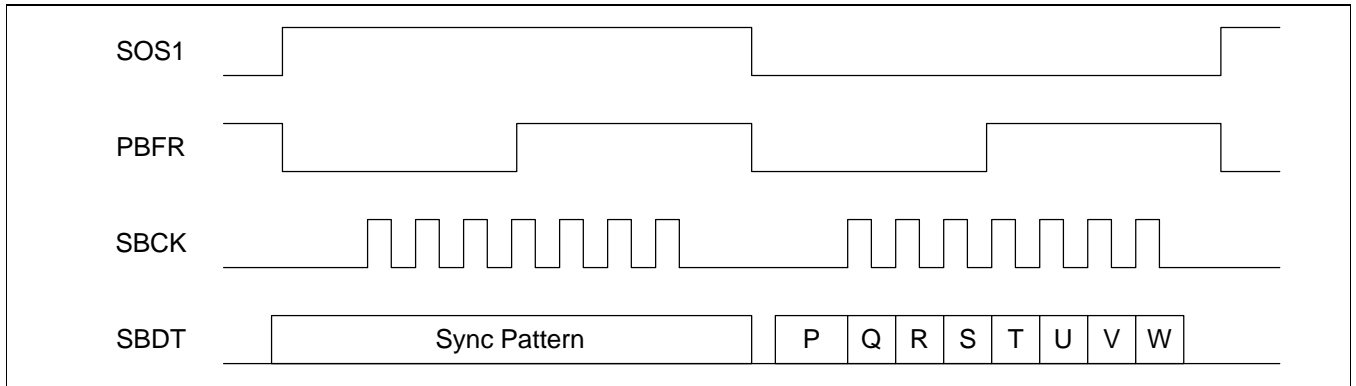

Figure 13. Digital Audio Data Out Timing Diagram

- (3) Channel status bit: subcode-Qs upper 4-bit data output, shows number of channels, pre-emphasis, copy, CDP-category, etc.

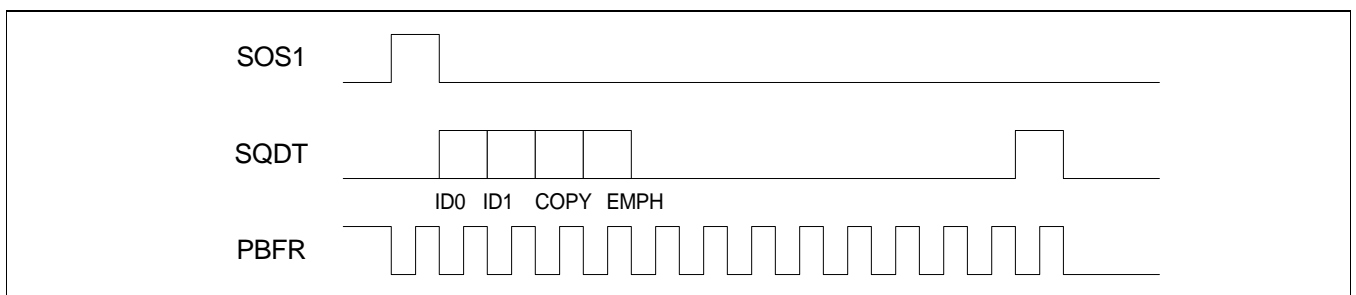

Figure 14. Channel Status Data Out Timing Diagram

- (4) Parity Bit: makes even parity

DIGITAL PLL

This IC has a built-in analog PLL and a digital PLL to generate a stable channel clock needed during EFM signal demodulation. Figure-15 shows the DPLL application.

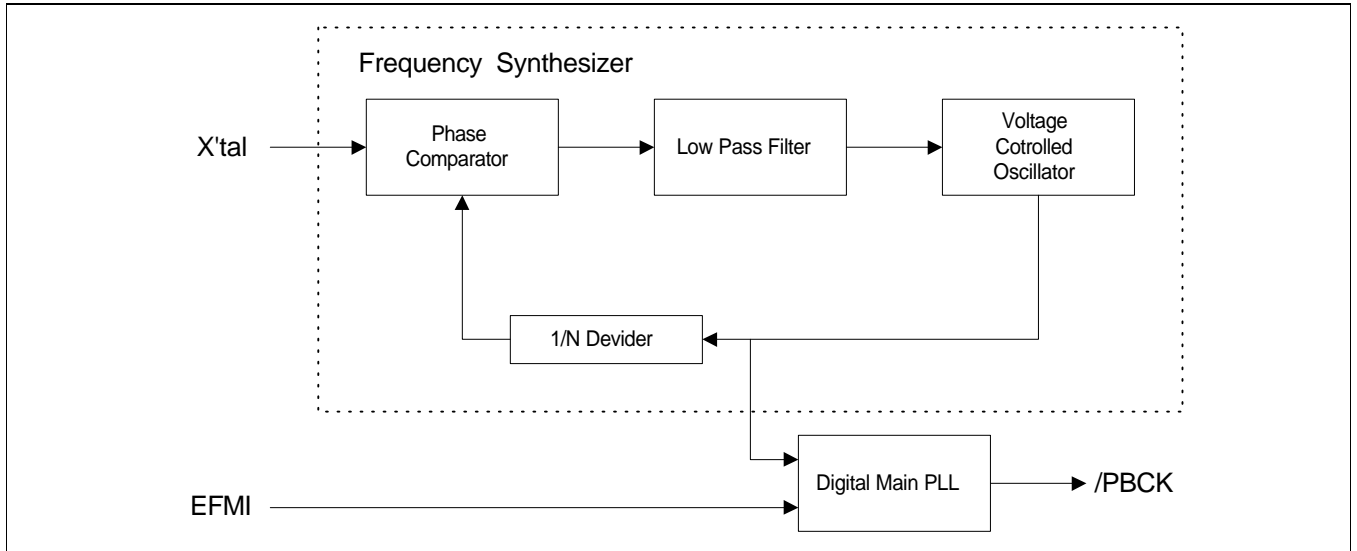

Figure 15. Application Diagram of Digital PLL