

# IL135Z

## INTEGRATED CIRCUIT OF TEMPERATURE SENSOR

(analog LM135Z, SGS-Thomson)

Microcircuit IL135Z is precision temperature sensor with calibration capacity . Microcircuit operates as Zener diode with brake down voltage being in direct proportion to to absolute temperature (10 mV/°K). Full dynamic resistance of the circuit is less than 1 Ohm at operation current 450 μA...5 mA. The sensor calibrated at the temperature 25°C, has typical error less than 1°C in the temperature range above 100°C. The peculiarity of the circuit IL135Z is the linear dependence of output voltage versus temperature.



**Packaged IC type:**

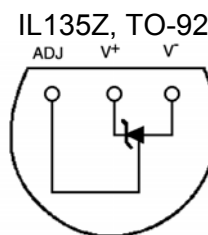

Bottom view

### IC features

- calibration in °K
  - initial measurement accuracy 1°K
  - range of operating supply current from 450 μA to 5 mA
- Full dynamic resistance less than 1 Ohm

**Figure 1 - Package pin definitions**

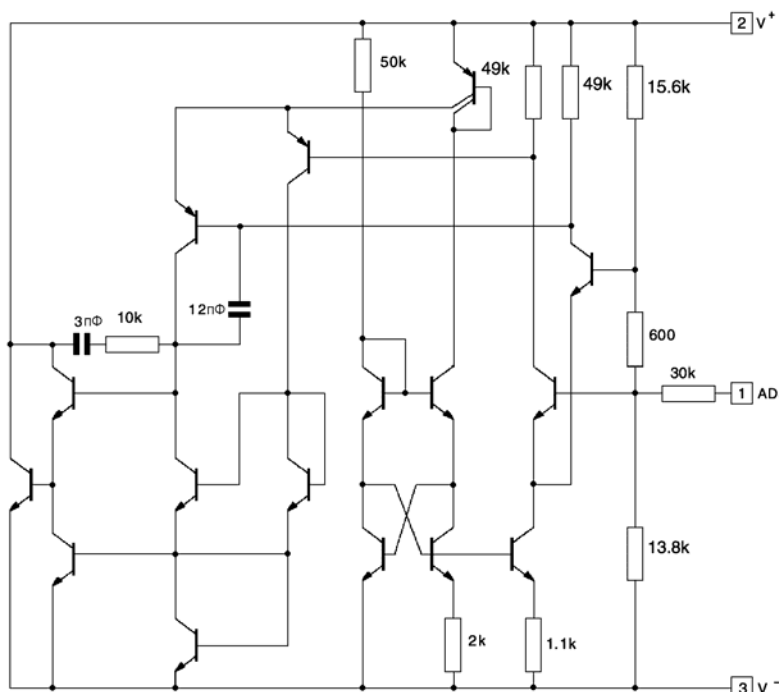

**Figure 2 - circuitry IL135Z.**



Korzhenevskogo 12, Minsk, 220064, Republic of Belarus  
 Fax: +375 (17) 278 28 22,  
 Phone: +375 (17) 278 07 11, 277 24 70, 277 24 61,  
 277 69 16  
 E-mail: [belms@belms.belpak.minsk.by](mailto:belms@belms.belpak.minsk.by)  
 URL: [www.bms.by](http://www.bms.by)

**BELMICROSYSTEMS**

## IL135Z

Table 1 - Maximum ratings

Name of parameter	Symbol	Standard		Unit of measurement
		min	max	
IC current reverse direct	$I_R$ $I_F$	- --	15 10	mA
<b>Air operation temperature: *</b> - constant mode - short-time	$T_{OPER}$	- 55 150	150 200	°C
Storage temperature	$T_{stg}$	-65	150	°C

**Note** -  $*T_J \leq 150^\circ\text{C}$

Table 2 – Temperature parameters.

Name of parameter	Symbol	Standard			Test conditions	Temperature °C	Unit
		min	Type	max			
output voltage, V	$U_{OUT}$	2,95	2,98	3,01	$I_R = 1 \text{ mA}$	25	V
Non-calibrated temperature error	$\Delta T_1$	-	1 2	3 5	$I_R = 1 \text{ mA}$	25 -55 ÷ 150	°C
temperature error at calibration 25°C	$\Delta T_2$	-	0,5	1,5	$I_R = 1 \text{ mA}$	-55 ÷ 150	°C
Calibrated error in extended temperature range	$\Delta T_3$	-	2	-	$T_{case} = T_{max}$ periodical	-55 ÷ 150	°C
Non-linearity of temperature characteristic	$\Delta T_4$	-	0,3	1	$I_R = 1 \text{ mA}$	-55 ÷ 150	°C

Table 3 – Electrical parameters.

Name of parameter	Symbol	Standard			Test conditions	Temperature °C	
		min	type.	max			
Measurement of output voltage in supply currents range	$\Delta U_{OUT}$	-	2,5	10	$0,45 \text{ mA} \leq I_R \leq 5 \text{ mA}$	-55 ÷ 150	mV
Dynamic impedance	$\Delta R_1$	-	0,5	-	$I_R = 1 \text{ mA}$	25	Ohm
Temperature coefficient of output voltage	TKH	-	+10	-	-	25	mV/°C
Time constant: -still air -speed of air is 0,5 m/c - agitated oil	$\tau_T$	- - -	80 10 1	- - -	-	-55 ÷ 150	C
Time stability	$T_{stab}$	-	0,2	-	-	125	°C/ 1000h

Note – Precise measurements done in agitated oil bath. For other conditions there should be taking into consideration self-heating .



IL135Z

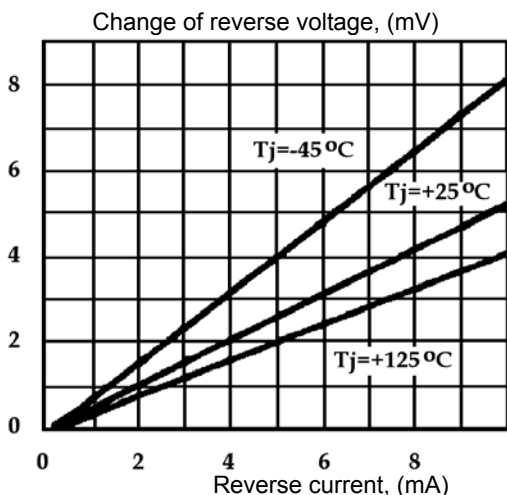

Figure 3 – Reverse voltage versus reverse current

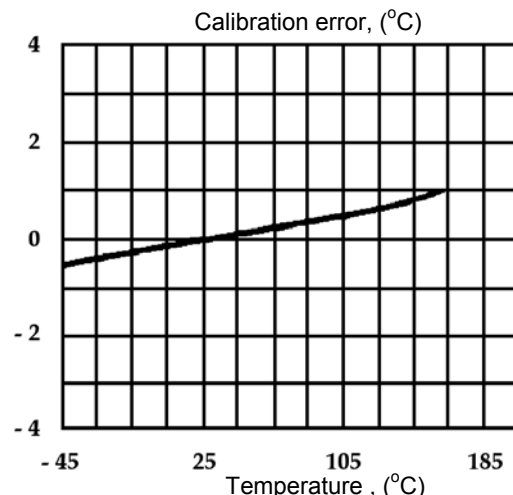

Figure 4 – Calibration error versus temperature

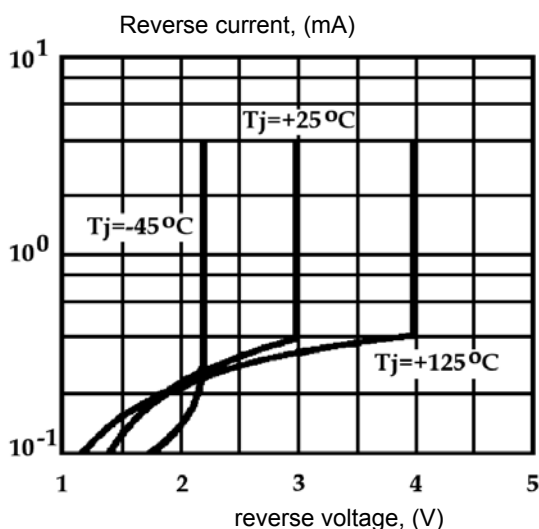

Figure 5 – Reverse current versus reverse voltage

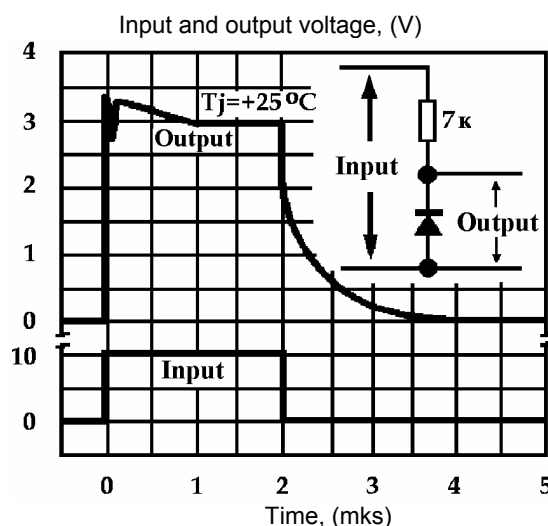

Figure 6 – Output signal response time



IL135Z

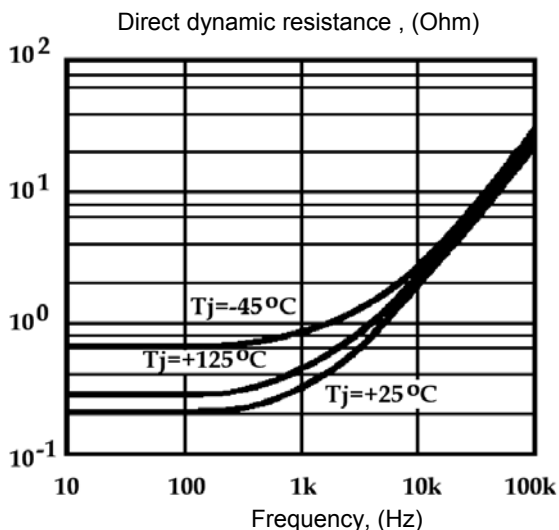

Figure 7 – Dynamic resistance versus frequency

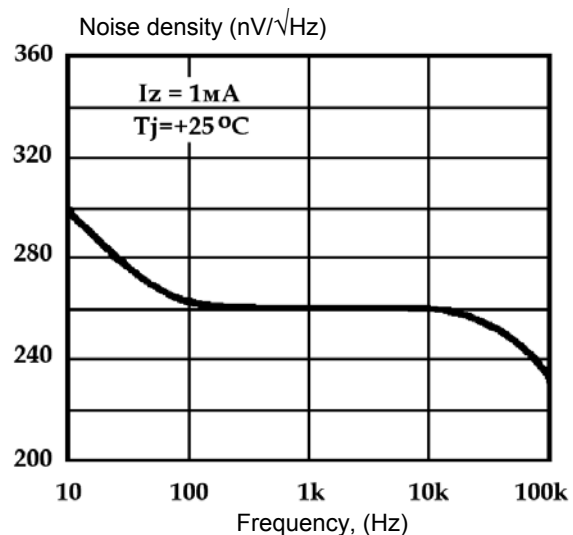

Figure 8 – Noise voltage

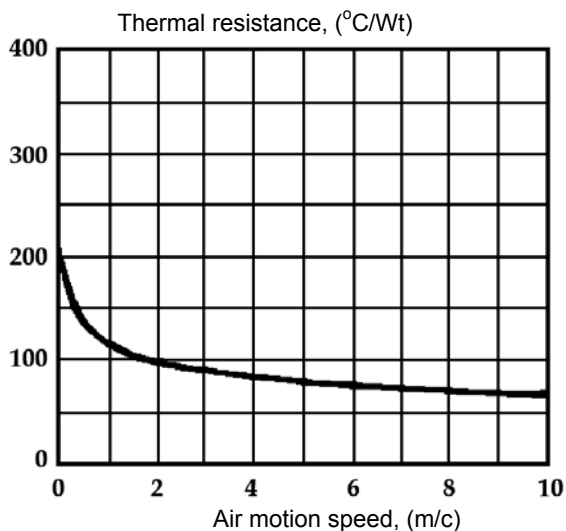

Figure 9 – Thermal resistance versus air motion speed

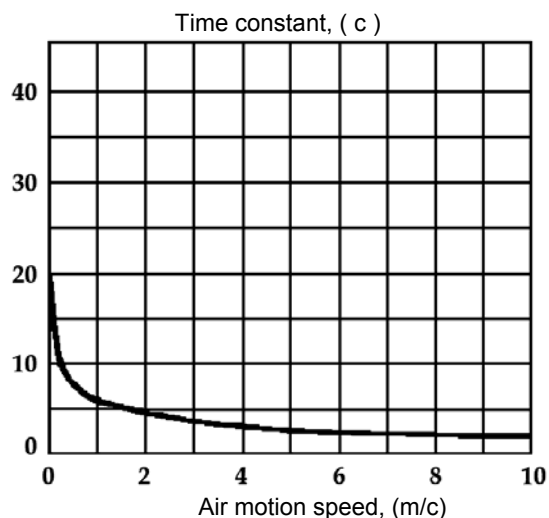

Figure 10 – Time constant versus air motion speed



IL135Z

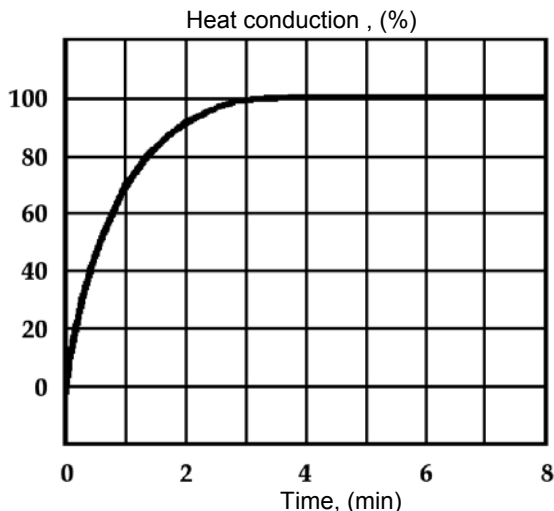

Figure 11 – Time dependence of heat conduction in still air

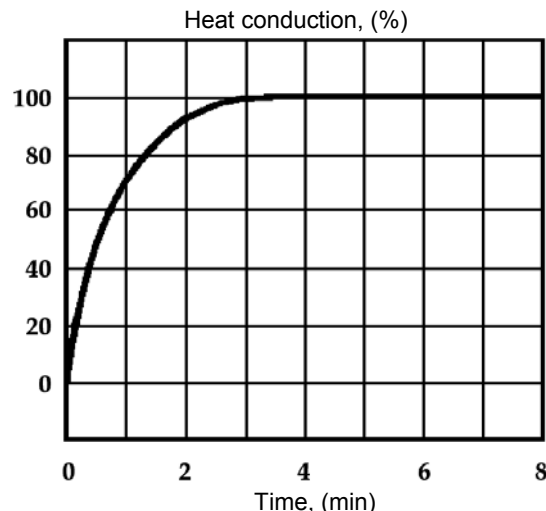

Figure 12 – Time dependence of heat conduction in agitated oil

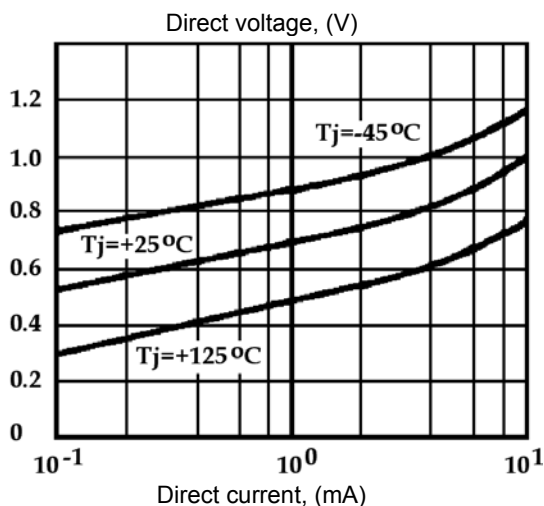

Figure 13 – Dependence of direct voltage on direct current

Information for application.

**There is a simple technique of the device calibration for improving precision of temperature measurement (see typical application circuits).**

Calibration of the device occurs in one spot as the IC output voltage is proportional to absolute temperature with sensor voltage extrapolation to 0 V at 0°K (-273,15°C). The errors in dependence of output voltage on temperature are determined only by characteristic incline. Therefore bias calibration at one temperature corrects errors in the whole temperature range. Output voltage of calibrated or non calibrated circuit may be derived from the following equation:

$$V_{OT} = VO_{TO} \frac{T}{T_0};$$

where T – unknown temperature;

T<sub>0</sub> – reference temperature (in °K).

Nominally IC output calibrated to the value 10 mV/°K.



Korzhenevskogo 12, Minsk, 220064, Republic of Belarus  
 Fax: +375 (17) 278 28 22,  
 Phone: +375 (17) 278 07 11, 277 24 70, 277 24 61,  
 277 69 16  
 E-mail: belms@belms.belpak.minsk.by  
 URL: www.bms.by

**BELMICROSYSTEMS**

## IL135Z

To ensure measurement precision they apply some rules. Degradation of the precision when self-heating is proper to any devices of temperature sensors. The circuit should operate at low operating current but sufficient for controlling the sensor and its calibration circuit at maximum operating temperature.

When using the sensor in the field with constant thermal resistance, error when self-heating may be reduced by external calibration. It can be done at the circuit bias when applying temperature-stabilized current. Thus heating will be proportional to Zener diode voltage. In this case error when self-heating is proportional to absolute temperature as the error of scaling coefficient.

### Typical application circuits.

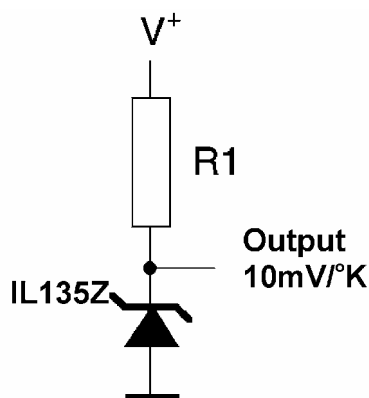

Figure 14 – Basic circuit of temperature sensor

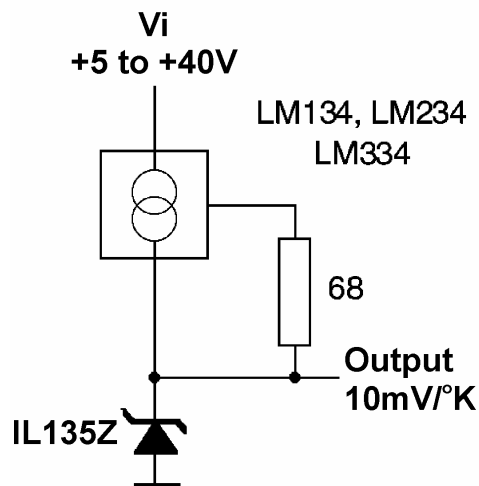

Figure 15 – Application circuit of temperature sensor with wide range supply voltage +15V

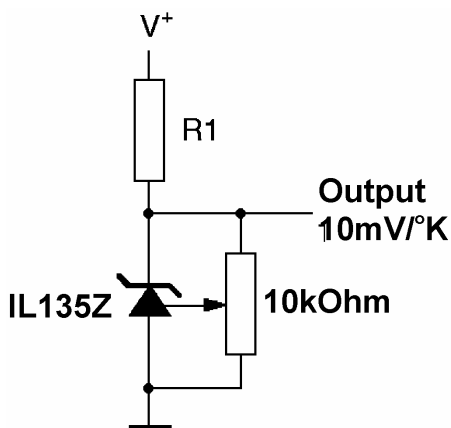

Figure 16 – Temperature sensor with external calibration \*

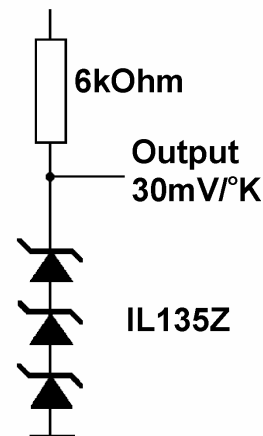

Figure 17 – Sequential sensor connection for increase of temperature bias voltage–



IL135Z

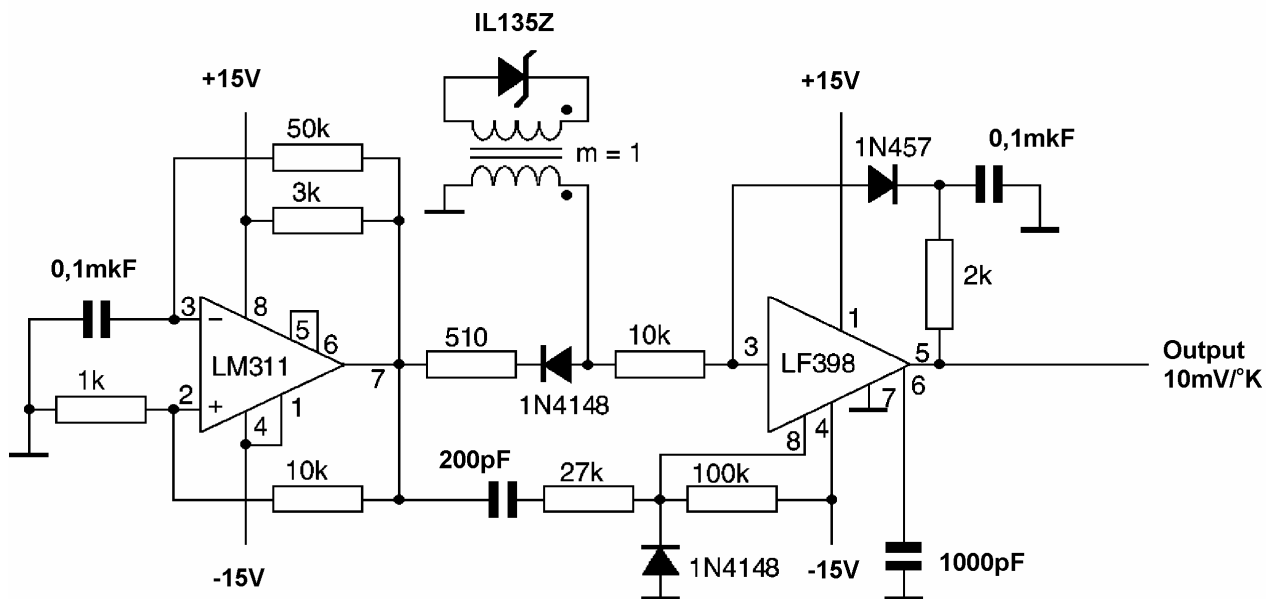

Figure 18 – Circuit of isolated temperature sensor

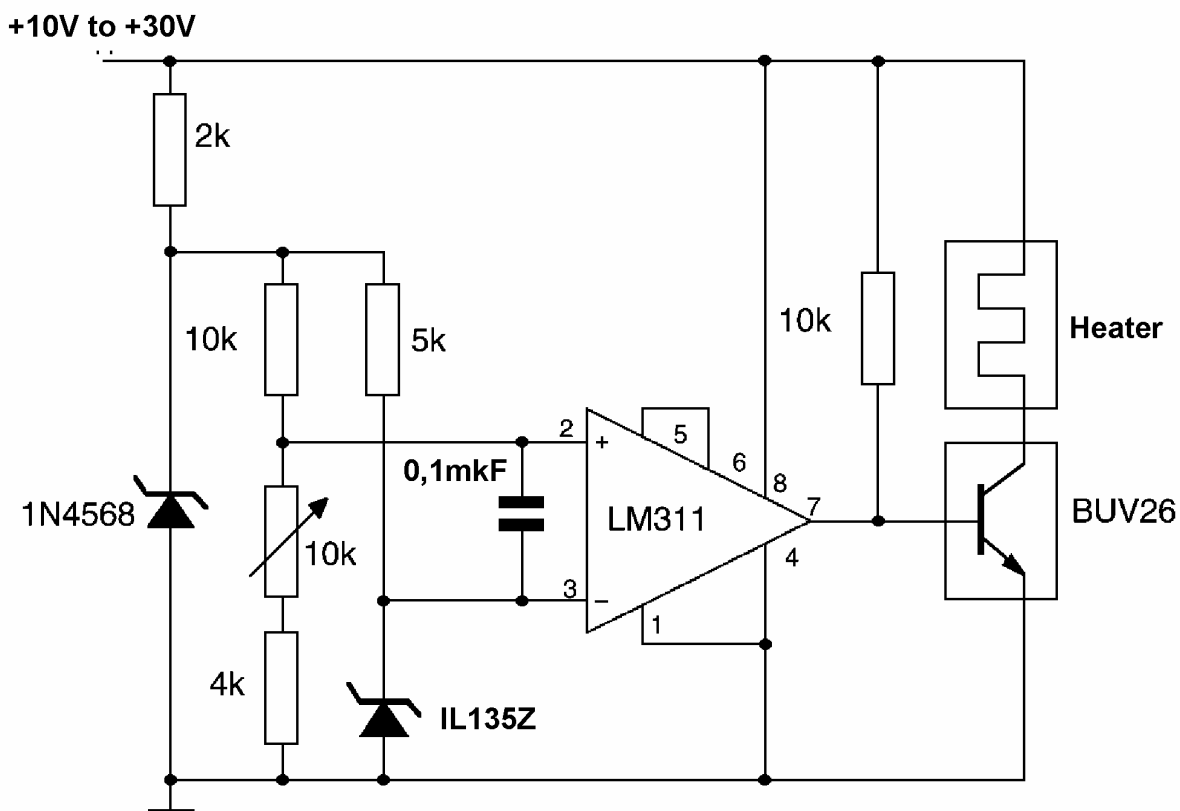

Figure 19 – Temperature regulator



IL135Z

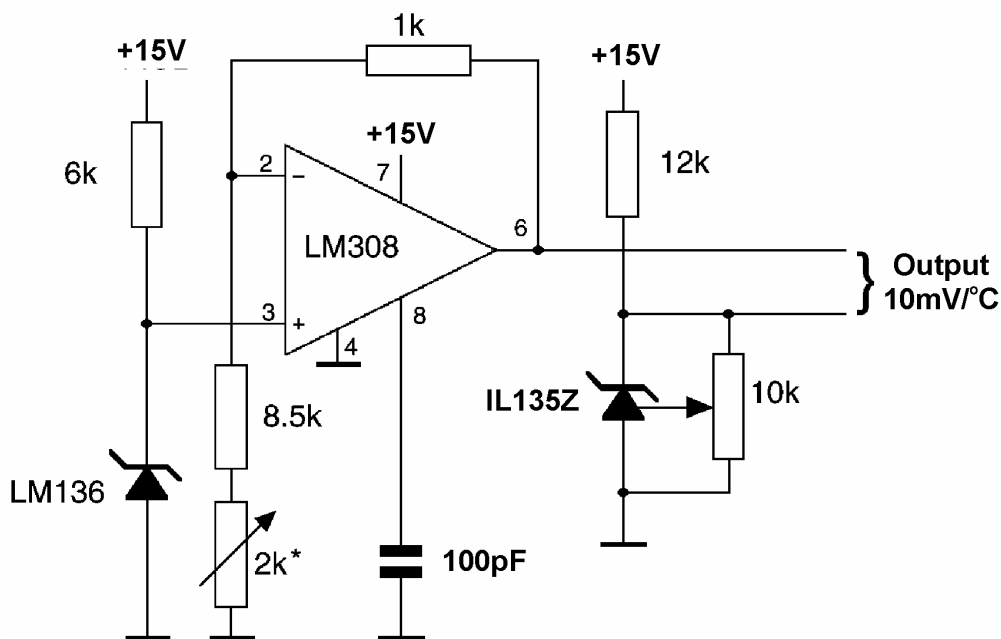

Figure 20 – Thermal sensor with 100° scale  
 \* Calibration for 2,7315 V on output of LM308

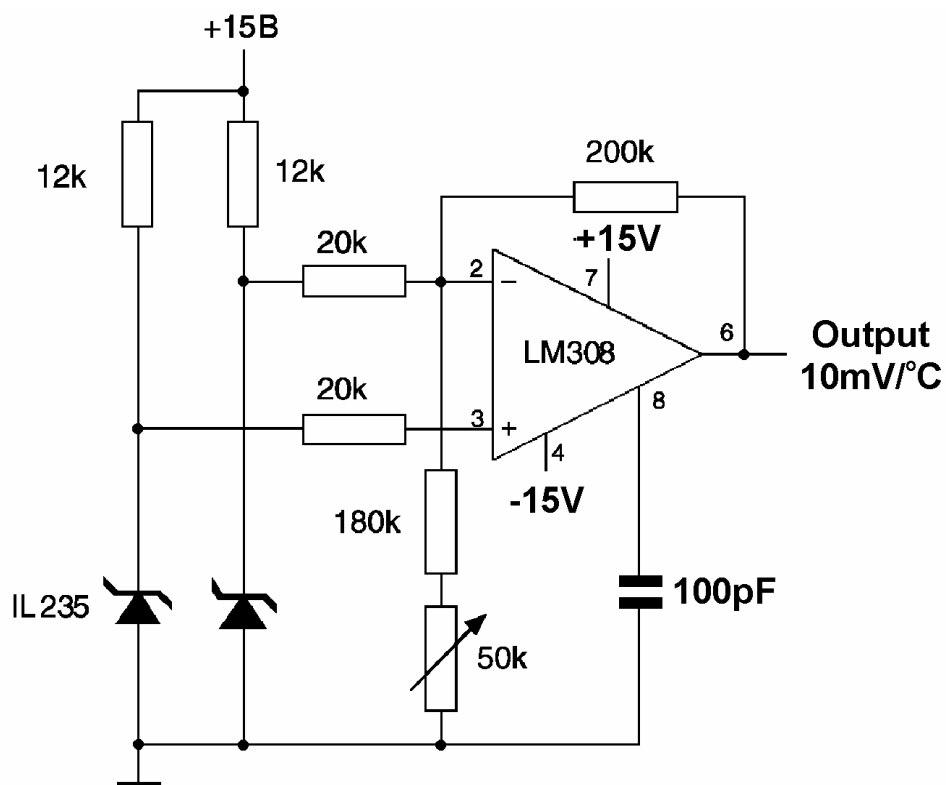
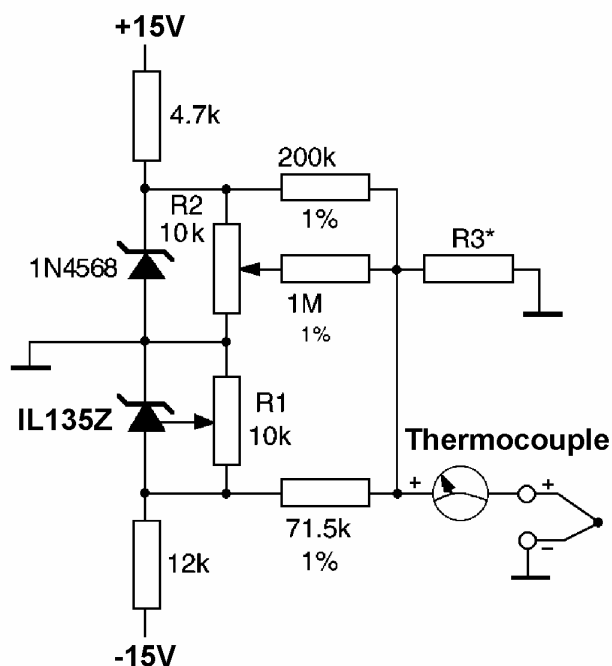

Figure 21 – Differential temperature sensor





IL135Z



Thermo couple	R3	Thermo electrical coefficient
J	377 Ohm	52,3 $\mu\text{V}/^\circ\text{C}$
T	308 Ohm	42,8 $\mu\text{V}/^\circ\text{C}$
K	293 Ohm	40,8 $\mu\text{V}/^\circ\text{C}$
S	45,8 Ohm	6,4 $\mu\text{V}/^\circ\text{C}$

Adjustment: compensation of sensor and resistor tolerances

1 Selection of 1N4568

2 Adjustment of voltage drop on element R3 by the resistor R1 to obtain the value of thermoelectrical coefficient, multiplied by the ambient temperature (in K degrees).

3 Selection of IL135Z and adjustment of R2 for setting voltage drop on the element R3 according to thermocouple type

J – 14,32 mV      K – 11,17 mV  
 T – 11,79 mV      S – 1,768 mV

Figure 22 – Circuit of cold junction compensation (compensation for ground thermocouple)  
 \*Value of R3 nominal for this thermocouple type



# IL135Z

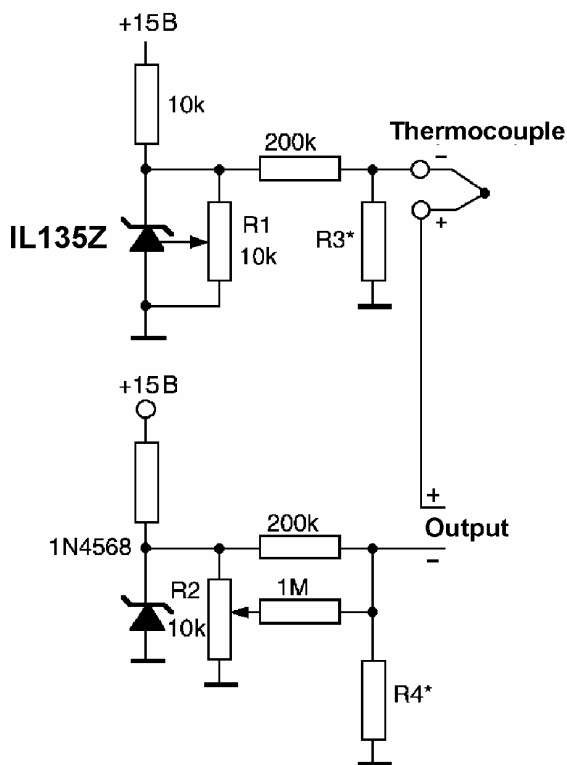

Thermocouple	R3	R4	Thermoelectrical coefficient
J	1050 Ohm	365 Ohm	52,3 $\mu\text{V}/^\circ\text{C}$
T	856 Ohm	315 Ohm	42,8 $\mu\text{V}/^\circ\text{C}$
K	816 Ohm	300 Ohm	40,8 $\mu\text{V}/^\circ\text{C}$
S	128 Ohm	46,3 Ohm	6,4 $\mu\text{V}/^\circ\text{C}$

**Adjustment: compensation of sensor and resistor tolerances**

- 1 Adjustment by the resistor R1 for obtaining voltage drop on the element R3, equal to thermoelectrical coefficient multiplied by the ambient temperature (in K degrees)
- 2 Adjustment of the resistor R2 for obtaining some voltage drop on the element R4 according to thermocouple type

J – 14,32 mV      K – 11,17 mV  
 T – 11,79 mV      S – 1,768 mV

**Figure 23 – Circuit of cold junction compensation with unipolar supply**  
 \*Value of R3 and R4 nominals for this thermocouple type

