

Features

- Operating voltage: 2.4V~5.0V
- Built-in AMP
- 2channel dual tone generator
- One Pin oscillator
- Current type D/A Output
- HT12E encoder pair with
- Tone optional: Ding-Dong/Westminster tunes
- 16-pin DIP package

General Description

The main application area for the HT12M device is for remote control doorbells working together with HT12E. Containing all the functions of the Holtek HT12D decoder and with an added amplifier and melody generator, the device eliminates the need for customers to incorporate an external op-amp and melody generator IC within their product applications, in the process significantly reducing overall product costs.

In addition to being fully compatible with the HT12D circuitry, the device includes the following features; internal Inverting AMP with can also operate as standard independent inverter, internal 2 channel tone generator and current type Audio output.

Block Diagram

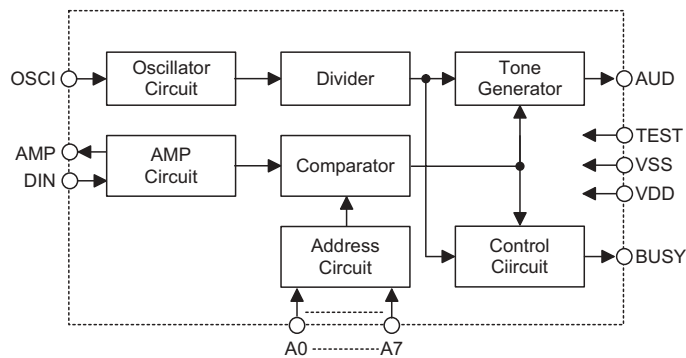

Pin Assignment

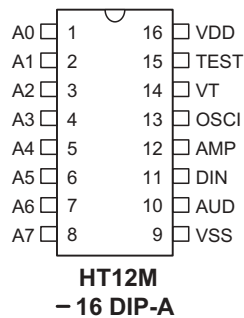

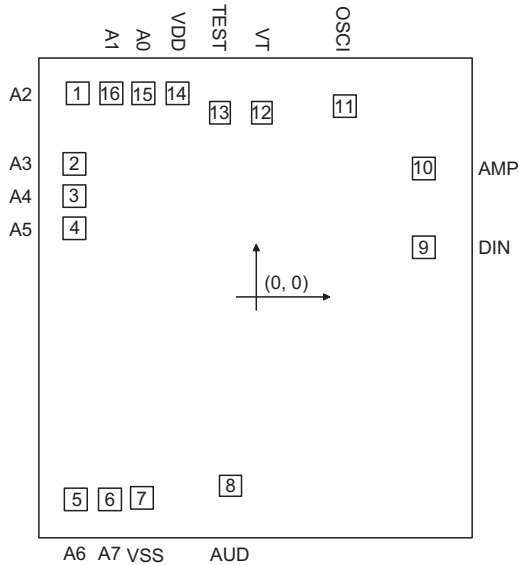
Pad Assignment

Chip Size: 1530 × 1690 μm

* The IC substrate should be connected to VSS in the PCB layout artwork.

Pad Coordinates

Unit: μm

| Pad No. | X | Y |
|---------|---------|---------|
| 1 | -610.00 | 701.90 |
| 2 | -622.00 | 461.60 |
| 3 | -622.00 | 350.60 |
| 4 | -622.00 | 239.70 |
| 5 | -616.00 | -695.20 |
| 6 | -502.00 | -695.20 |
| 7 | -388.50 | -687.70 |
| 8 | -87.95 | -647.80 |
| 9 | 575.80 | 172.40 |
| 10 | 575.80 | 444.20 |
| 11 | 308.30 | 660.40 |
| 12 | 22.10 | 635.90 |
| 13 | -122.40 | 638.40 |
| 14 | -270.40 | 701.90 |
| 15 | -384.50 | 701.90 |
| 16 | -495.50 | 701.90 |

Pin Description

| Pin No. | Pin Name | I/O | Internal Connection | Description |
|---------|----------|-----|---------------------|-------------------------------|
| 1~8 | A0~A7 | I | NMOS Open Drain | Address pin. |
| 9 | VSS | — | — | Negative power supply, ground |
| 10 | AUD | O | PMOS Open Drain | Audio out |
| 11 | DIN | I | COMS In | Serial data input |
| 12 | AMP | O | CMOS | Amp feed back |
| 13 | OSCI | I | — | Oscillator input pin. |
| 14 | VT | O | CMOS | Busy, data valid |
| 15 | TEST | I | CMOS In | Test pin. |
| 16 | VDD | — | — | Positive power supply |

Absolute Maximum Ratings

| | | | |
|----------------------|--|-----------------------------|----------------|
| Supply Voltage | -0.3V to 5.5V | Storage Temperature | -50°C to 125°C |
| Input Voltage | V _{SS} -0.3V to V _{DD} +0.3V | Operating Temperature | -25°C to 70°C |

Note: These are stress ratings only. Stresses exceeding the range specified under "Absolute Maximum Ratings" may cause substantial damage to the device. Functional operation of this device at other conditions beyond those listed in the specification is not implied and prolonged exposure to extreme conditions may affect device reliability.

D.C. Characteristics

| Symbol | Parameter | Test Conditions | | Min. | Typ. | Max. | Unit |
|------------------|--------------------------|-----------------|-------------------------------------|------|------|------|------|
| | | V _{DD} | Conditions | | | | |
| V _{DD} | Operating Voltage | — | — | 2.4 | — | 5 | V |
| I _{STB} | Standby Current | 5V | OSC stop amp off | — | 0.1 | 1 | μA |
| | | 5V | OSC stop amp on | — | 10 | 20 | μA |
| I _{DD} | Operating Current | 5V | No load f _{OSC} =150kHz | — | 1.5 | 2 | mA |
| I _{AUD} | AUD output current | 5V | Transistor B load | 3 | 5 | — | mA |
| I _{VT} | VT Output Source Current | 5V | V _{OH} =4.5V | -2 | -3 | — | mA |
| | VT Output Sink Current | 5V | V _{OL} =0.5V | 2 | 3 | — | mA |
| V _{IH} | High Input Voltage | 5V | — | 3.5 | — | 5 | V |
| V _{IL} | Low Input Voltage | 5V | — | 0 | — | 1 | V |
| f _{OSC} | Oscillator Frequency | 5V | ROSC=820kΩ | — | 190 | — | kHz |

Functional Description

Built-in inverter amp

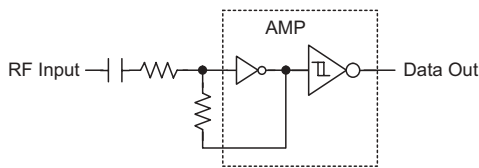

Single tone has 4 second total length, dual tone has 1 second total length.

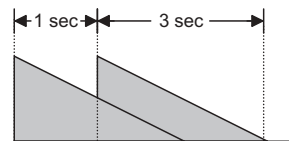

Trigger mode

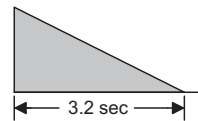
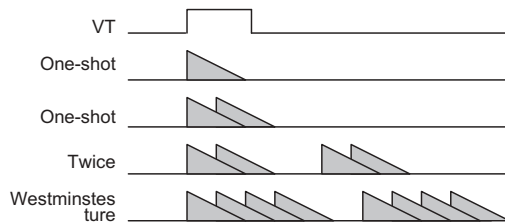

The Ding-Dong sound: is determined by the D8–D11 pins on the HT12E. While the Re-trigger/Non-trigger function is determined by the D11 pin on the HT12E.

| | D11 | D10 | D9 | D8 | Sound | Notes |
|---|-----|-----|----|----|---------------------------|------------------|
| 1 | | 0 | 0 | 0 | Me | 1 |
| 2 | | 0 | 0 | 1 | Me Do | 2 |
| 3 | | 0 | 1 | 0 | Me Do — Me Do | Repeat |
| 4 | | 0 | 1 | 1 | Me/Do | Single tone |
| 5 | | 1 | 0 | 0 | Me Do Re So — So Re Me Do | Westminster tune |
| 6 | | 1 | 0 | 1 | Me/Do Do/So | Double tone |
| 7 | | 1 | 1 | 0 | So Re Me Do | 4 |
| 8 | | 1 | 1 | 1 | Me/Do Do/So — Me/Do Do/So | Dual Tone-repeat |

Section time: 0.8secretary × 2 = 1.6sec

Application Circuit

HT12E/HT12M pairing application circuit

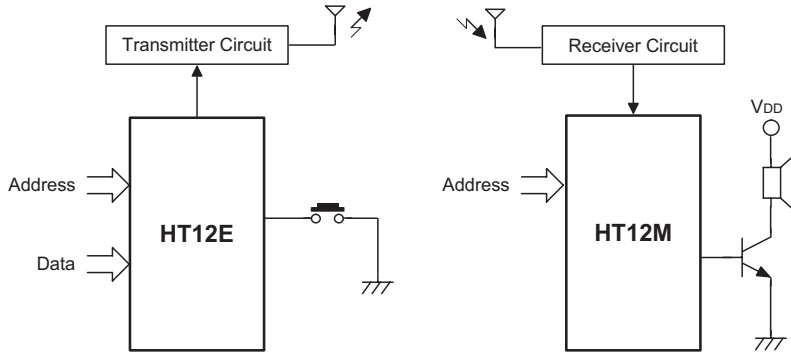

Using internal OP amplifier circuit

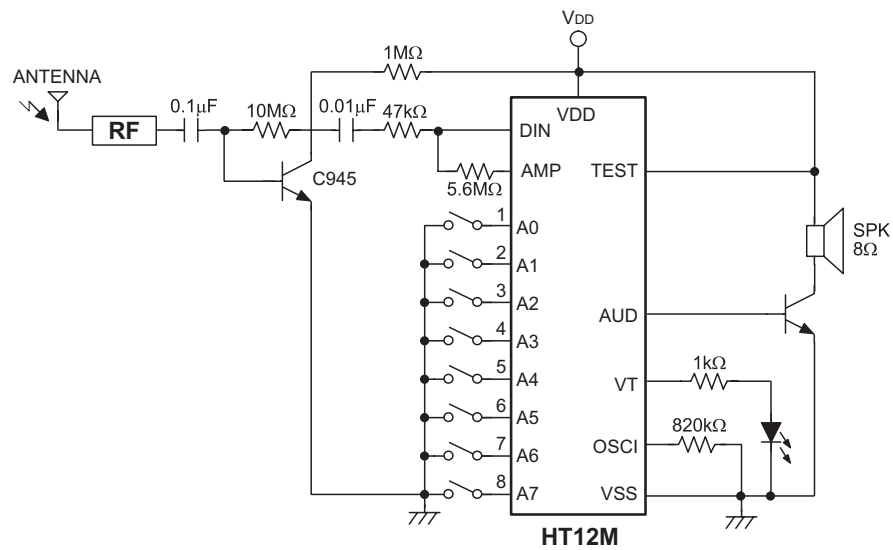

Using external OP amplifier circuit

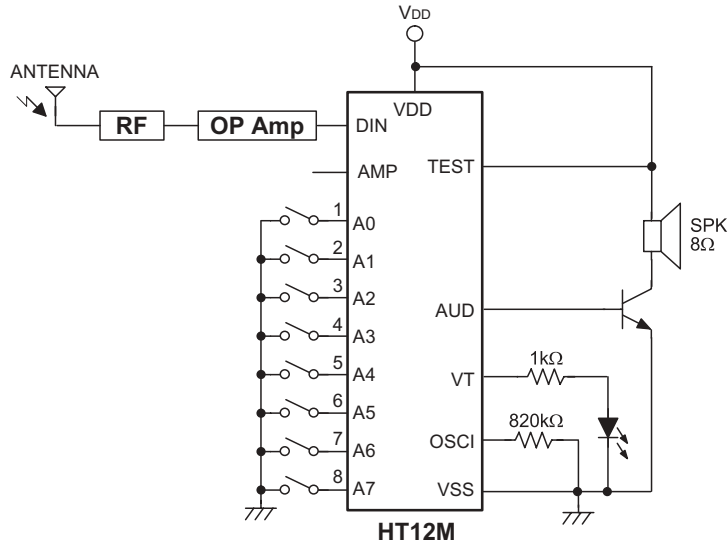

Typical RF-Receiver circuit

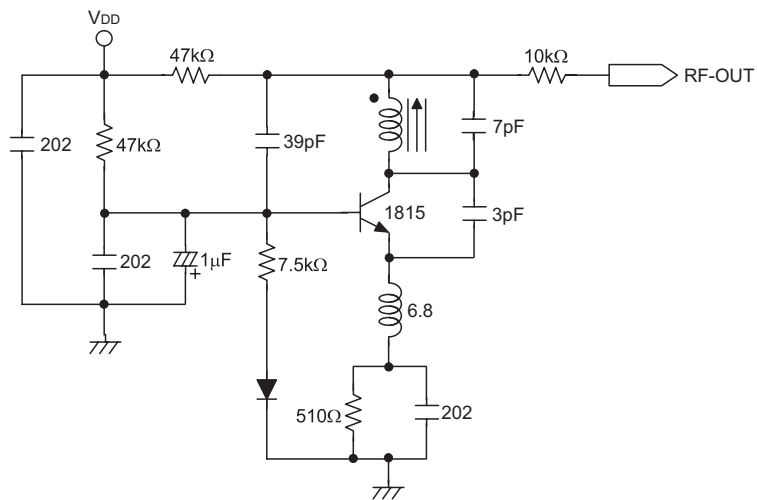

Holtek Semiconductor Inc. (Headquarters)

No.3, Creation Rd. II, Science-based Industrial Park, Hsinchu, Taiwan
Tel: 886-3-563-1999
Fax: 886-3-563-1189
<http://www.holtek.com.tw>

Holtek Semiconductor Inc. (Sales Office)

11F, No.576, Sec.7 Chung Hsiao E. Rd., Taipei, Taiwan
Tel: 886-2-2782-9635
Fax: 886-2-2782-9636
Fax: 886-2-2782-7128 (International sales hotline)

Holtek Semiconductor (Hong Kong) Ltd.

RM.711, Tower 2, Cheung Sha Wan Plaza, 833 Cheung Sha Wan Rd., Kowloon, Hong Kong
Tel: 852-2-745-8288
Fax: 852-2-742-8657

Holtek Semiconductor (Shanghai) Inc.

7th Floor, Building 2, No.889, Yi Shan Rd., Shanghai, China
Tel: 021-6485-5560
Fax: 021-6485-0313
<http://www.holtek.com.cn>

Holmate Technology Corp.

48531 Warm Springs Boulevard, Suite 413, Fremont, CA 94539
Tel: 510-252-9880
Fax: 510-252-9885
<http://www.holmate.com>

Copyright © 2002 by HOLTEK SEMICONDUCTOR INC.

The information appearing in this Data Sheet is believed to be accurate at the time of publication. However, Holtek assumes no responsibility arising from the use of the specifications described. The applications mentioned herein are used solely for the purpose of illustration and Holtek makes no warranty or representation that such applications will be suitable without further modification, nor recommends the use of its products for application that may present a risk to human life due to malfunction or otherwise. Holtek reserves the right to alter its products without prior notification. For the most up-to-date information, please visit our web site at <http://www.holtek.com.tw>.