

2.4 GHz FRONT-END LNA / SWITCH IC

FEBRUARY 2001

v01.0900

Features

INTEGRATED LNA & SWITCH

INTEGRATED POWER CONTROL:
+3V OPERATION

IDEAL FOR 802.11, HomeRF,
& *BLUETOOTH* APPLICATIONS

ULTRA SMALL 8 LEAD MSOP:
14.8 mm² x 1mm High



General Description

The HMC309MS8 is a versatile integrated low noise amplifier (LNA) and transmit/receive switch front-end for 2.3 to 2.5 GHz spread spectrum applications including BLUETOOTH, HomeRF, 802.11 WLAN, and 2.4 GHz ISM radios. The LNA offers 8 dB gain and 2.5 dB noise figure while the transmit switch path has 0.5 dB insertion loss and better than +30 dBm linear power handling. Using a single control line, the LNA is powered down when the switch Tx port is selected minimizing I_{dd} current consumption to 5 mA in the Rx mode and 120 uA in the Tx mode at V_{dd} = +3V bias. The HMC309MS8 may be directly interfaced with popular 2.4 GHz transceiver chips. At a height of 0.040" (1.0mm), the MSOP8 package is ideal for low profile portable wireless devices.

Guaranteed Performance, V_{dd} = +3V, -40 to +85 deg C

Parameter	LNA (Rx) Path			Switched Path			Units
	Min.	Typ.	Max.	Min.	Typ.	Max.	
Frequency Range	2.3 - 2.5			2.3 - 2.5			GHz
Gain	6	8	10	-0.6	-0.4		dB
Gain Flatness		± 0.5			± 0.1		dB
Noise Figure		2.5	3.0		0.45		dB
Input Return Loss		5		17	25		dB
Output Return Loss		13		16	20		dB
Output or Input Power for 1dB Compression (P1dB)*	2	6		30	33		dBm
Output or Input Third Order Intercept (IP3) *	5	8		27	40		dBm
Recommended Supply Voltage (V _{dd})	2.75	3.0	3.25	2.75	3.0	3.25	Vdc
Supply Current (I _{dd})(V _{dd} = +3.0 Vdc)		5	10		0.2	0.4	mA

* The LNA P1dB & IP3 are referenced to the Rx pin output while the switch P1dB & IP3 are referenced to the Tx pin input.

2.4 GHz FRONT-END LNA / SWITCH IC

v01.0900

FEBRUARY 2001

LNA Broadband Gain & Return Loss

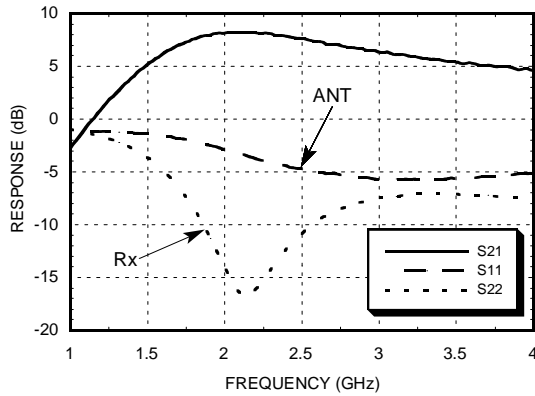

LNA Gain vs. Temperature, ANT to Rx

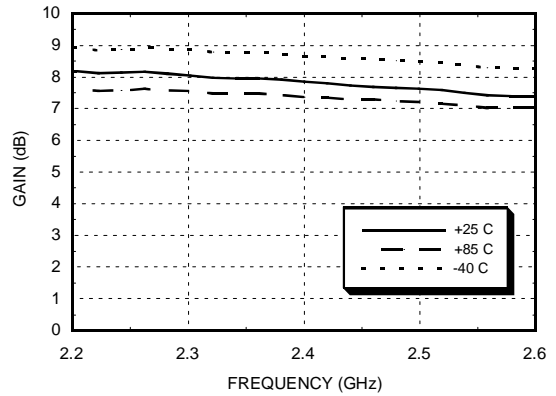

LNA Input Match @ ANT vs. Temperature

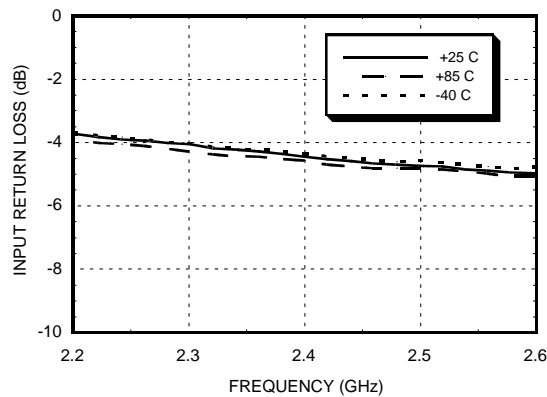

LNA Output Match @ Rx vs. Temperature

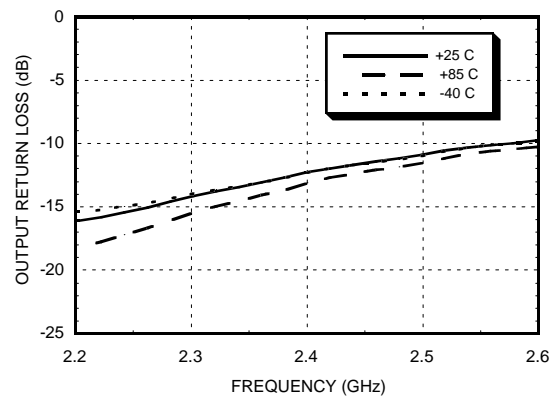

LNA Noise Figure vs Temperature ANT to Rx

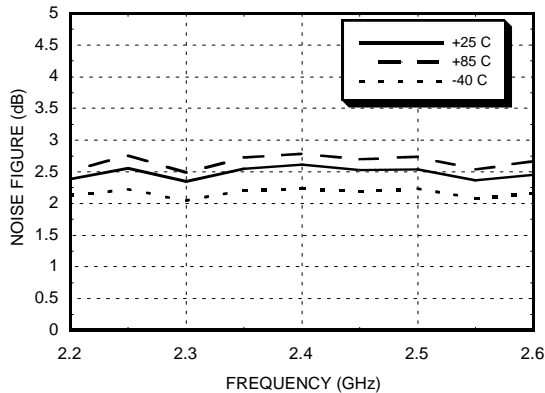

LNA Power Compression @ 2.4 GHz

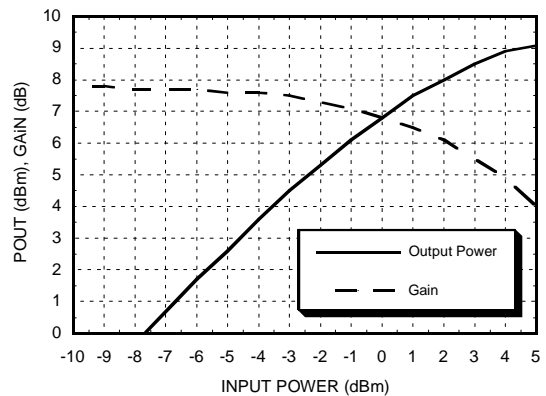

1
AMPLIFIERS
SMT



2.4 GHz FRONT-END LNA / SWITCH IC

FEBRUARY 2001

v01.0900

1
AMPLIFIERS
SMT

Switch Path Broadband Insertion Loss and Return Loss

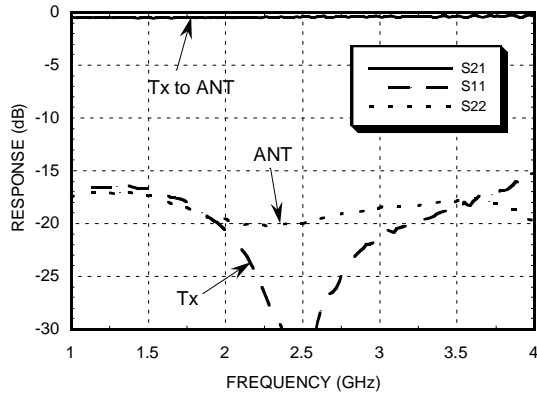

Switch Path Insertion Loss vs. Temperature, Tx to ANT

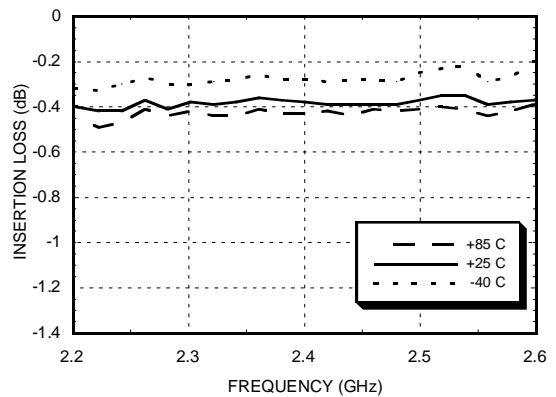

Switch Path Input Match @ Tx vs. Temperature

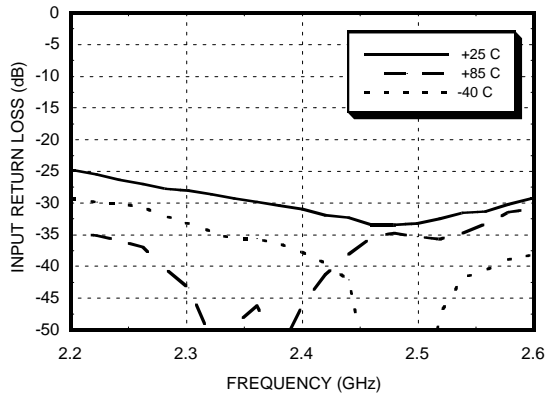

Switch Path Output Match @ ANT vs. Temperature

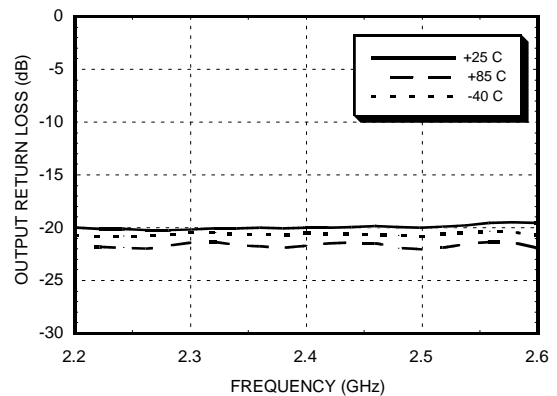

IP3 vs. Temperature

Temperature	Frequency = 2.4 GHz	
	LNA (Rx) Path	Switched Path
-40 °C	8.3	41.4
+25 °C	8.2	39.6
+85 °C	7.8	44.2

*All levels in dBm
LNA path Output IP3 referenced to Rx port.
Switched path Input IP3 referenced to Tx port.*

Tx/Rx Isolation

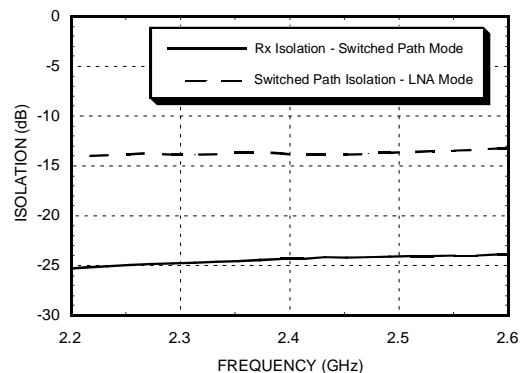

2.4 GHz FRONT-END LNA / SWITCH IC

v01.0900

FEBRUARY 2001

Schematic

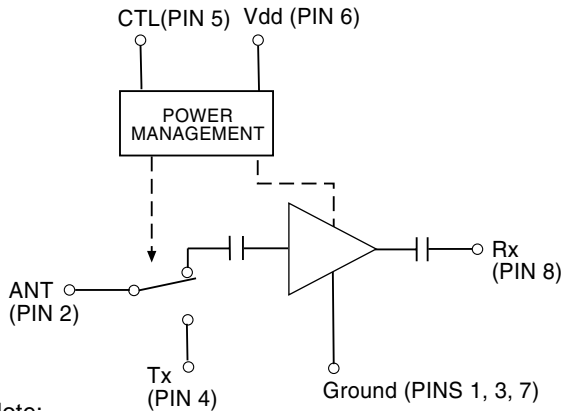

Note:
DC blocking capacitors are required on the ANT port (Pin 2) and the Tx port (Pin 4).

Absolute Maximum Ratings

Supply Voltage (Vdd)	+8 Vdc
Control Voltage Range (CTL)	-0.2v to Vdd
Input Power @ ANT (LNA "ON", Vdd = +3V)	-10 dBm
Input Power @ Tx (Switch "ON", Vdd = +3V)	+ 34 dBm
Channel Temperature (Tc)	175 °C
Thermal Resistance (jc) (Channel Backside)	32 °C/W
Storage Temperature	-65 to +150 °C
Operating Temperature	-55 to +85 °C



Truth Table

Control Input Tolerances are ± 0.2 Vdc

Control Input (Vdc)	Signal Path	
	ANT to Rx	Tx to ANT
0	On	Off
+3	Off	On

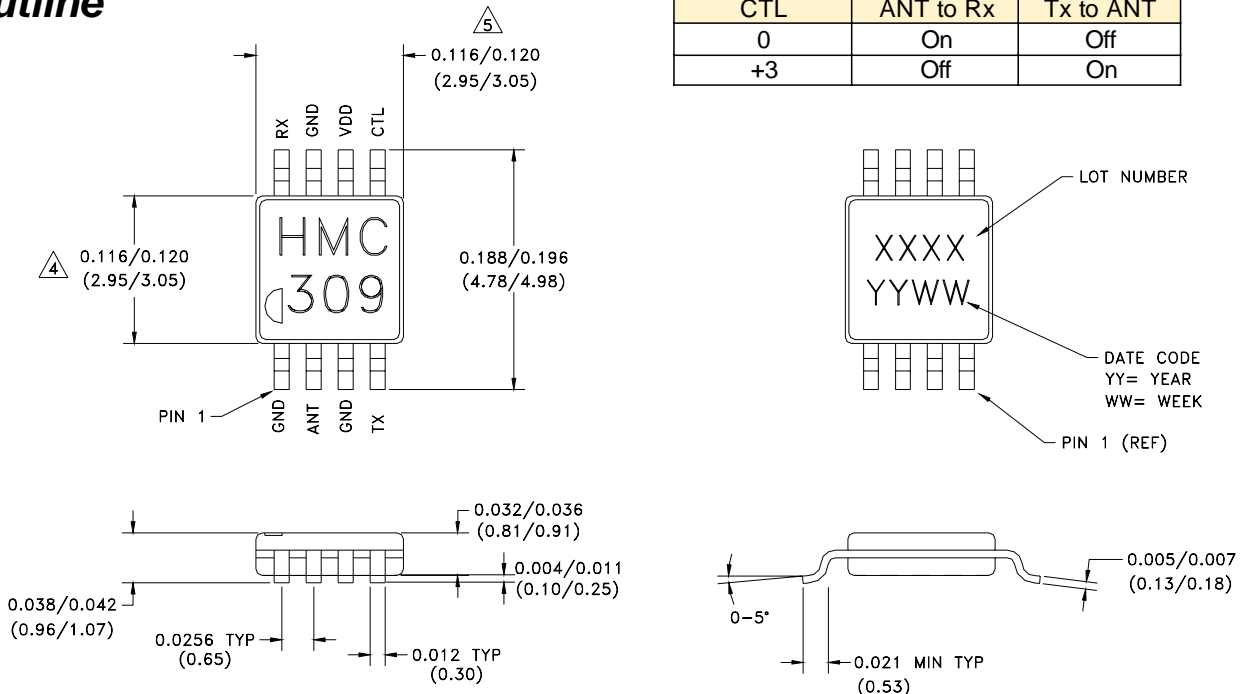
Outline



- | | |
|--|--|
| <p>1. MATERIAL:
A) PACKAGE BODY - LOW STRESS INJECTION-MOLDED PLASTIC.
B) LEADFRAME MATERIAL: COPPER ALLOY</p> <p>2. PLATING : LEAD - TIN SOLDER PLATE</p> | <p>3. DIMENSIONS ARE IN INCHES (MILLIMETERS).
UNLESS OTHERWISE SPECIFIED ALL TOL. ARE ±0.005(±0.13).</p> <p> DIMENSION DOES NOT INCLUDE MOLDFLASH OF 0.15 MM PER SIDE</p> <p> DIMENSION DOES NOT INCLUDE MOLDFLASH OF 0.25 MM PER SIDE</p> |
|--|--|

1
AMPLIFIERS
SMT

2.4 GHz FRONT-END LNA / SWITCH IC

FEBRUARY 2001

v01.0900

Evaluation PCB for HMC309MS8

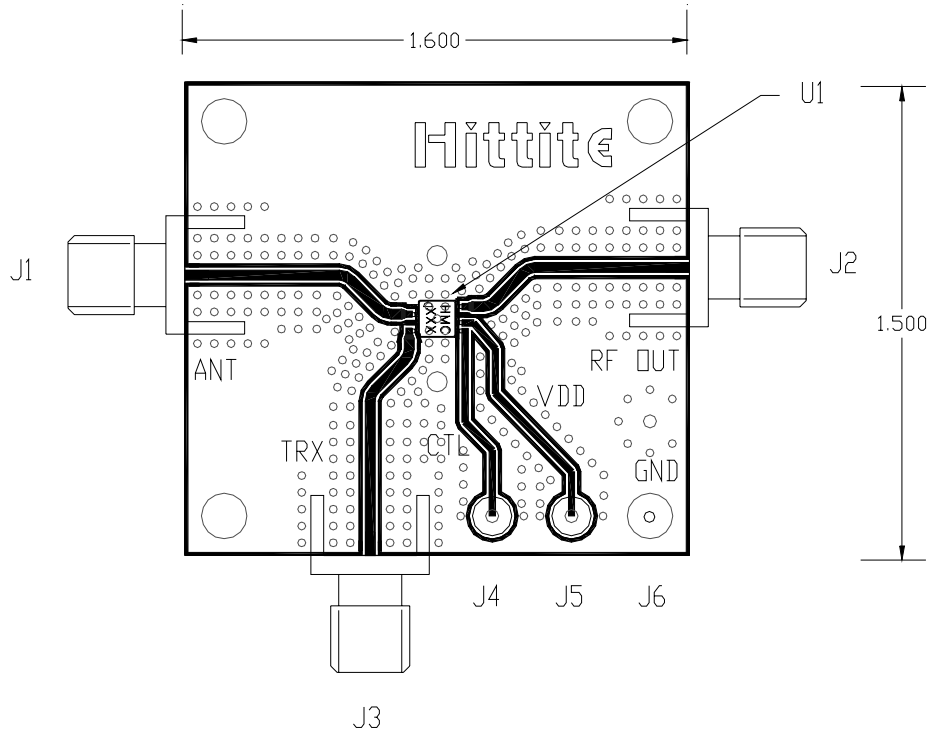

The circuit board used in the final application should use RF circuit design techniques. Signal lines should have 50 ohm impedance while the package ground leads should be connected directly to the ground plane similar to that shown above. A sufficient number of VIA holes should be used to connect the top and bottom ground planes. The evaluation circuit board as shown is available from Hittite upon request.

List of Material

Item	Description
J1, J2, J3	PC Mount SMA RF Connector
J4, J5, J6	DC Pins
U1	HMC309MS8 Amplifier
PCB*	Eval Board 1.5" x 1.5"
*Circuit Board Material: Rogers 4350	

2.4 GHz FRONT-END LNA / SWITCH IC

v01.0900

FEBRUARY 2001

NOTES:

1

AMPLIFIERS

SMT

