

GENERAL DESCRIPTION

The HI-8599 from Holt Integrated Circuits is a silicon gate CMOS device for interfacing a 16-bit parallel data bus directly to the ARINC 429 serial bus. This device provides two receivers, an independent transmitter and line driver capability in a single package. The receiver input circuitry and logic are designed to meet the ARINC 429 specifications for loading, level detection, timing, and protocol. The transmitter section provides the ARINC 429 communication protocol and the line driver circuits provide the ARINC 429 output levels.

The 16-bit parallel data bus exchanges the 32-bit ARINC data word in two steps when either loading the transmitter or interrogating the receivers. The data bus interfaces with CMOS and TTL.

The HI-8599 provides the option to bypass most of the internal output resistance so that external series resistance may be added for lightning protection and still match the 75 ohm characteristic impedance of the ARINC bus.

Each independent receiver monitors the data stream with a sampling rate 10 times the data rate. The sampling rate is software selectable at either 1MHz or 125KHz. The results of a parity check are available as the 32nd ARINC bit. The HI-8599 examines the null and data timings and will reject erroneous patterns. For example, with a 125 KHz clock selection, the data frequency must be between 10.4 KHz and 15.6 KHz.

The transmitter has a First In, First Out (FIFO) memory to store 8 ARINC words for transmission. The data rate of the transmitter is software selectable by dividing the master clock, CLK, by either 10 or 80. The master clock is used to set the timing of the ARINC transmission within the required resolution.

APPLICATIONS

- Avionics data communication
- Serial to parallel conversion
- Parallel to serial conversion

FEATURES

- ARINC specification 429 compliant
- Direct receiver and transmitter interface to ARINC bus in a single device
- 16-Bit parallel data bus
- Timing control 10 times the data rate
- Selectable data clocks
- Receiver error rejection per ARINC specification 429
- Automatic transmitter data timing
- Self test mode
- Parity functions
- Low power
- Industrial & full military temperature ranges

PIN CONFIGURATION (Top View)

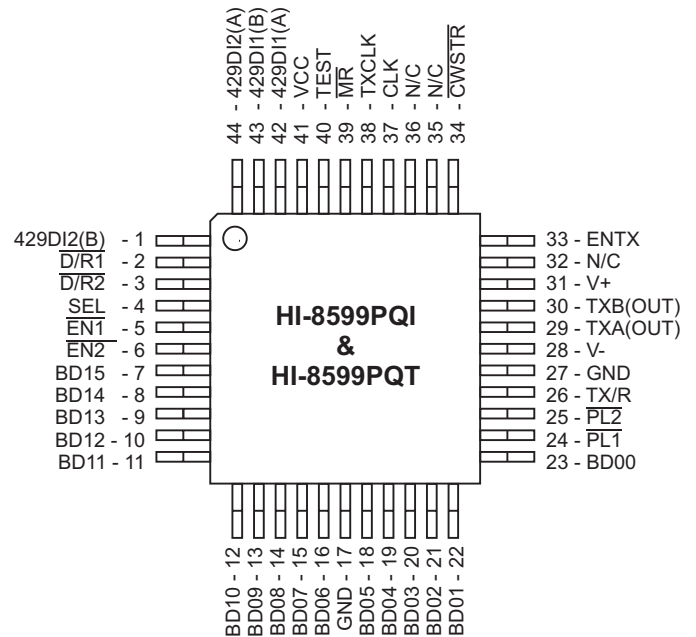

44-Pin Plastic Quad Flat Pack (PQFP)

(See page 12 for additional pin configurations)

PIN DESCRIPTION

| SIGNAL | FUNCTION | DESCRIPTION |
|--------------------|----------|---|
| V _{CC} | POWER | +5V ±5% |
| V+ | POWER | +9.5V to +10.5V |
| V- | POWER | -9.5V to -10.5V |
| 429DI1 (A) | INPUT | ARINC receiver 1 positive input |
| 429DI1 (B) | INPUT | ARINC receiver 1 negative input |
| 429DI2 (A) | INPUT | ARINC receiver 2 positive input |
| 429DI2 (B) | INPUT | ARINC receiver 2 negative input |
| $\overline{D/R1}$ | OUTPUT | Receiver 1 data ready flag |
| $\overline{D/R2}$ | OUTPUT | Receiver 2 data ready flag |
| SEL | INPUT | Receiver data byte selection (0 = BYTE 1) (1 = BYTE 2) |
| $\overline{EN1}$ | INPUT | Data Bus control, enables receiver 1 data to outputs |
| $\overline{EN2}$ | INPUT | Data Bus control, enables receiver 2 data to outputs if $\overline{EN1}$ is high |
| BD15 | I/O | Data Bus |
| BD14 | I/O | Data Bus |
| BD13 | I/O | Data Bus |
| BD12 | I/O | Data Bus |
| BD11 | I/O | Data Bus |
| BD10 | I/O | Data Bus |
| BD09 | I/O | Data Bus |
| BD08 | I/O | Data Bus |
| BD07 | I/O | Data Bus |
| BD06 | I/O | Data Bus |
| GND | POWER | 0 V |
| BD05 | I/O | Data Bus |
| BD04 | I/O | Data Bus |
| BD03 | I/O | Data Bus |
| BD02 | I/O | Data Bus |
| BD01 | I/O | Data Bus |
| BD00 | I/O | Data Bus |
| TX/R | OUTPUT | Transmitter ready flag. Goes low when ARINC word loaded into FIFO. Goes high after transmission and FIFO empty. |
| $\overline{PL1}$ | INPUT | Latch enable for byte 1 entered from data bus to transmitter FIFO. |
| $\overline{PL2}$ | INPUT | Latch enable for byte 2 entered from data bus to transmitter FIFO. Must follow $\overline{PL1}$. |
| TXA(OUT) | OUTPUT | Line driver output - A side |
| TXB(OUT) | OUTPUT | Line driver output - B side |
| ENTX | INPUT | Enable Transmission |
| \overline{CWSTR} | INPUT | Clock for control word register |
| CLK | INPUT | Master Clock input |
| TX CLK | OUTPUT | Transmitter Clock equal to Master Clock (CLK), divided by either 10 or 80. |
| \overline{MR} | INPUT | Master Reset, active low |
| TEST | INPUT | Disable Transmitter output if high (pull-down) |

FUNCTIONAL DESCRIPTION

CONTROL WORD REGISTER

The HI-8599 contains 10 data flip flops whose D inputs are connected to the data bus and clocks connected to CWSTR. Each flip flop provides options to the user as follows:

| DATA BUS PIN | FUNCTION | CONTROL | DESCRIPTION |
|--------------|----------------------|--------------------|---|
| BDO5 | SELF TEST | 0 = ENABLE | If enabled, the transmitter's digital outputs are internally connected to the receiver logic inputs |
| BDO6 | RECEIVER 1 DECODER | 1 = ENABLE | If enabled, ARINC bits 9 and, 10 must match the next two control word bits |
| BDO7 | - | - | If Receiver 1 Decoder is enabled, the ARINC bit 9 must match this bit |
| BDO8 | - | - | If Receiver 1 Decoder is enabled, the ARINC bit 10 must match this bit |
| BDO9 | RECEIVER 2 DECODER | 1 = ENABLE | If enabled, ARINC bits 9 and 10 must match the next two Control word bits |
| BD10 | - | - | If Receiver 2 Decoder is enabled, then ARINC bit 9 must match this bit |
| BD11 | - | - | If Receiver 2 Decoder is enabled, then ARINC bit 10 must match this bit |
| BD12 | INVERT XMTR PARITY | 1 = ENABLE | Logic 0 enables normal odd parity and Logic 1 enables even parity output in transmitter 32nd bit |
| BD13 | XMTR DATA CLK SELECT | 0 = ÷10 1 = ÷80 | CLK is divided either by 10 or 80 to obtain XMTR data clock |
| BD14 | RCVR DTA CLK SELECT | 0 = ÷10 1 = ÷80 | CLK is divided either by 10 or 80 to obtain RCVR data clock |

ARINC 429 DATA FORMAT

The following table shows the bit positions in exchanging data with the receiver or the transmitter. ARINC bit 1 is the first bit transmitted or received.

| BYTE 1 | | | | | | | | | | | | | | | | |
|-----------|-------|-------|-------|-------|-------|-------|-------|-------|-------|-------|-------|-------|-------|-------|-------|-------|
| DATA BUS | BD 15 | BD 14 | BD 13 | BD 12 | BD 11 | BD 10 | BD 09 | BD 08 | BD 07 | BD 06 | BD 05 | BD 04 | BD 03 | BD 02 | BD 01 | BD 00 |
| ARINC BIT | 13 | 12 | 11 | 10 | 9 | 31 | 30 | 32 | 1 | 2 | 3 | 4 | 5 | 6 | 7 | 8 |

| BYTE 2 | | | | | | | | | | | | | | | | |
|-----------|-------|-------|-------|-------|-------|-------|-------|-------|-------|-------|-------|-------|-------|-------|-------|-------|
| DATA BUS | BD 15 | BD 14 | BD 13 | BD 12 | BD 11 | BD 10 | BD 09 | BD 08 | BD 07 | BD 06 | BD 05 | BD 04 | BD 03 | BD 02 | BD 01 | BD 00 |
| ARINC BIT | 29 | 28 | 27 | 26 | 25 | 24 | 23 | 22 | 21 | 20 | 19 | 18 | 17 | 16 | 15 | 14 |

THE RECEIVERS

ARINC BUS INTERFACE

Figure 1 shows the input circuit for each receiver. The ARINC 429 specification requires the following detection levels:

| STATE | DIFFERENTIAL VOLTAGE |
|-------|--------------------------|
| ONE | +6.5 Volts to +13 Volts |
| NULL | +2.5 Volts to -2.5 Volts |
| ZERO | -6.5 Volts to -13 Volts |

The HI-8599 guarantees recognition of these levels with a common mode Voltage with respect to GND less than ±4V for the worst case condition (4.75V supply and 13V signal level).

The tolerances in the design guarantee detection of the above levels, so the actual acceptance ranges are slightly larger. If the ARINC signal is out of the actual acceptance ranges, including the nulls, the chip rejects the data.

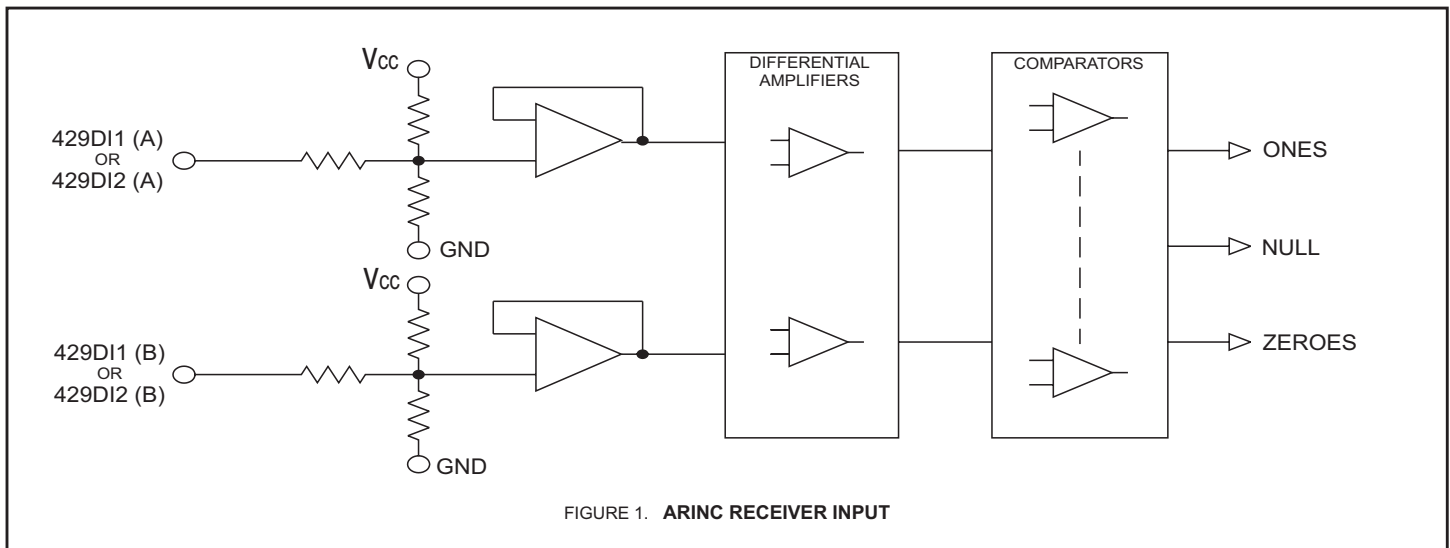

FIGURE 1. ARINC RECEIVER INPUT

FUNCTIONAL DESCRIPTION (cont.)

RECEIVER LOGIC OPERATION

Figure 2 shows a block diagram of the logic section of each receiver.

BIT TIMING

The ARINC 429 specification contains the following timing specification for the received data:

| | <u>HIGH SPEED</u> | <u>LOW SPEED</u> |
|------------------------|-------------------|-------------------|
| BIT RATE | 100K BPS ± 1% | 12K -14.5K BPS |
| PULSE RISE TIME | 1.5 ± 0.5 µsec | 10 ± 5 µsec |
| PULSE FALL TIME | 1.5 ± 0.5 µsec | 10 ± 5 µsec |
| PULSE WIDTH | 5 µsec ± 5% | 34.5 to 41.7 µsec |

The HI-8599 accepts signals that meet these specifications and rejects outside the tolerances. The way the logic operation achieves this is described below:

1. Key to the performance of the timing checking logic is an accurate 1MHz clock source. Less than 0.1% error is recommended.
2. The sampling shift registers are 10 bits long and must show three consecutive Ones, Zeros or Nulls to be considered valid data. Additionally, for data bits, the One or Zero in the upper bits of the sampling shift registers must be followed by a Null in the lower bits within the data bit time. For a Null in the word gap, three consecutive Nulls must be found in both the upper and lower bits of the sampling shift register. In this manner the minimum pulse width is guaranteed.

3. Each data bit must follow its predecessor by not less than 8 samples and no more than 12 samples. In this manner the bit rate is checked. With exactly 1MHz input clock frequency, the acceptable data bit rates are as follows:

| | <u>HIGH SPEED</u> | <u>LOW SPEED</u> |
|--------------------------|-------------------|------------------|
| DATA BIT RATE MIN | 83K BPS | 10.4K BPS |
| DATA BIT RATE MAX | 125K BPS | 15.6K BPS |

4. The Word Gap timer samples the Null shift register every 10 input clocks (80 for low speed) after the last data bit of a valid reception. If the Null is present, the Word Gap counter is incremented. A count of 3 will enable the next reception.

RECEIVER PARITY

The receiver parity circuit counts Ones received, including the parity bit, ARINC bit 32. If the result is odd, then "0" will appear in the 32nd bit.

RETRIEVING DATA

Once 32 valid bits are recognized, the receiver logic generates an End of Sequence (EOS). If the receiver decoder is enabled and the 9th and 10th ARINC bits match the control word program bits or if the receiver decoder is disabled, then EOS clocks the data ready flag flip flop to a "1", D/R1 or D/R2 (or both) will go low. The data flag for a receiver will remain low until after both ARINC bytes from that receiver are retrieved. This is accomplished by first activating EN with SEL, the byte selector, low to retrieve the first byte and then activating EN with SEL high to retrieve the second byte. EN1 retrieves data from receiver 1 and EN2 retrieves data from receiver 2.

If another ARINC word is received and a new EOS occurs before the two bytes are retrieved, the data is overwritten by the new word.

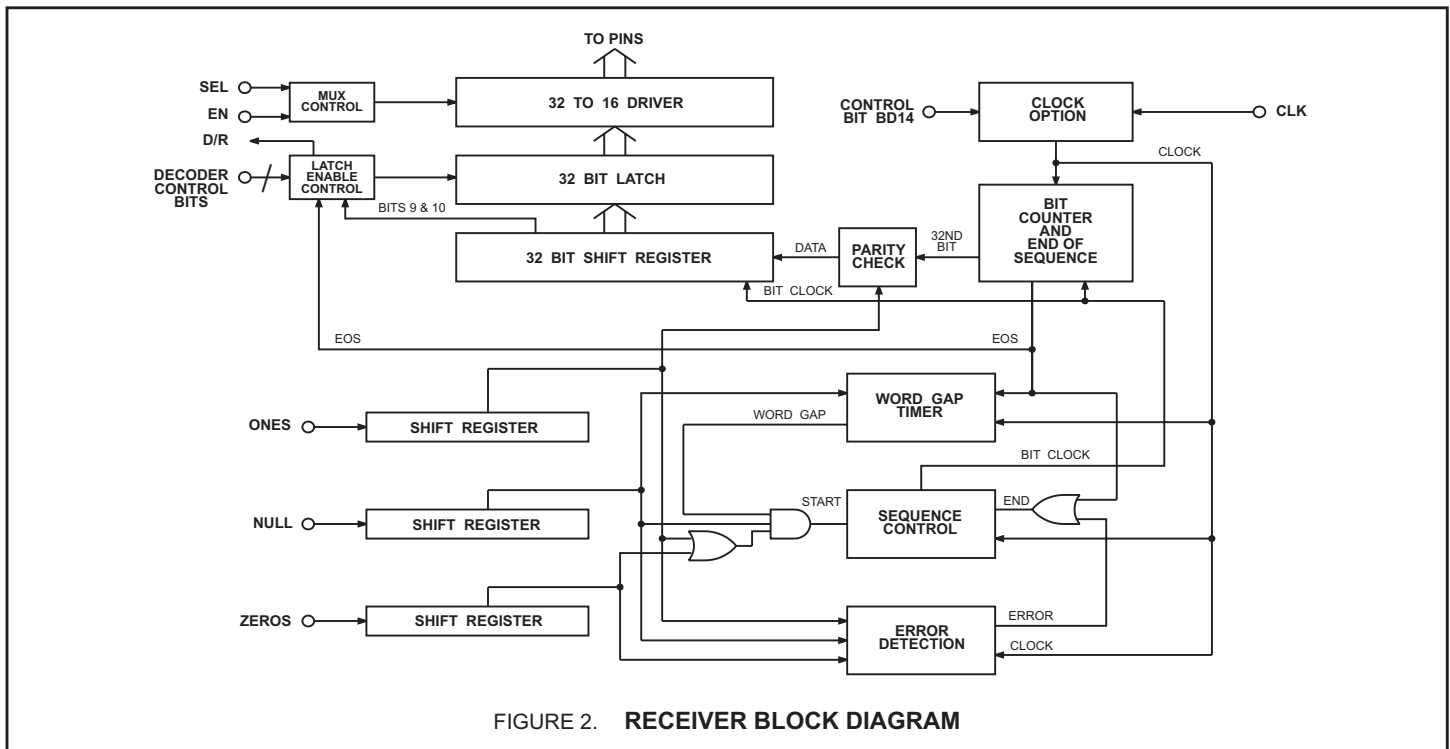

FIGURE 2. RECEIVER BLOCK DIAGRAM

FUNCTIONAL DESCRIPTION (cont.)

TRANSMITTER

A block diagram of the transmitter section is shown in Figure 3.

FIFO OPERATION

The FIFO is loaded sequentially by first pulsing $\overline{PL1}$ to load byte 1 and then $\overline{PL2}$ to load byte 2. The control logic automatically loads the 31 bit word in the next available position of the FIFO. If TX/R, the transmitter ready flag is high (FIFO empty), then 8 words, each 31 bits long, may be loaded. If TX/R is low, then only the available positions may be loaded. If all 8 positions are full, the FIFO ignores further attempts to load data.

DATA TRANSMISSION

When ENTX goes high, enabling transmission, the FIFO positions are incremented with the top register loading into the data transmission shift register. Within 2.5 data clocks the first data bit appears at either TXA(OUT) or TXB(OUT). The 31 bits in the data transmission shift register are presented sequentially to the outputs in the ARINC 429 format with the following timing:

| | <u>HIGH SPEED</u> | <u>LOW SPEED</u> |
|---------------------|-------------------|------------------|
| ARINC DATA BIT TIME | 10 Clocks | 80 Clocks |
| DATA BIT TIME | 5 Clocks | 40 Clocks |
| NULL BIT TIME | 5 Clocks | 40 Clocks |
| WORD GAP TIME | 40 Clocks | 320 Clocks |

The word counter detects when all loaded positions are transmitted and sets the transmitter ready flag, TX/R, high.

TRANSMITTER PARITY

The parity generator counts the ONES in the 31-bit word. If the BD12 control word bit is set low, the 32nd bit transmitted will make parity odd. If the control bit is high, the parity is even.

SELF TEST

If the BD05 control word bit is set low, the digital outputs of the transmitter are internally connected to the logic inputs of the receivers, bypassing the analog bus interface circuitry. Data to Receiver 1 is as transmitted and data to Receiver 2 is the complement. All data transmitted during self test is also present on the TXA(OUT) and TXB(OUT) line driver outputs. Taking TEST high forces TXA(OUT) and TXB(OUT) into the null state regardless of the state of Bd05 control word bit.

SYSTEM OPERATION

The two receivers are independent of the transmitter. Therefore, control of data exchanges is strictly at the option of the user. The only restrictions are:

1. The received data may be overwritten if not retrieved within one ARINC word cycle.
2. The FIFO can store 8 words maximum and ignores attempts to load addition data if full.
3. Byte 1 of the transmitter data must be loaded first.
4. Either byte of the received data may be retrieved first. Both bytes must be retrieved to clear the data ready flag.
5. After ENTX, transmission enable, goes high it cannot go low until TX/R, transmitter ready flag, goes high. Otherwise, one ARINC word is lost during transmission.

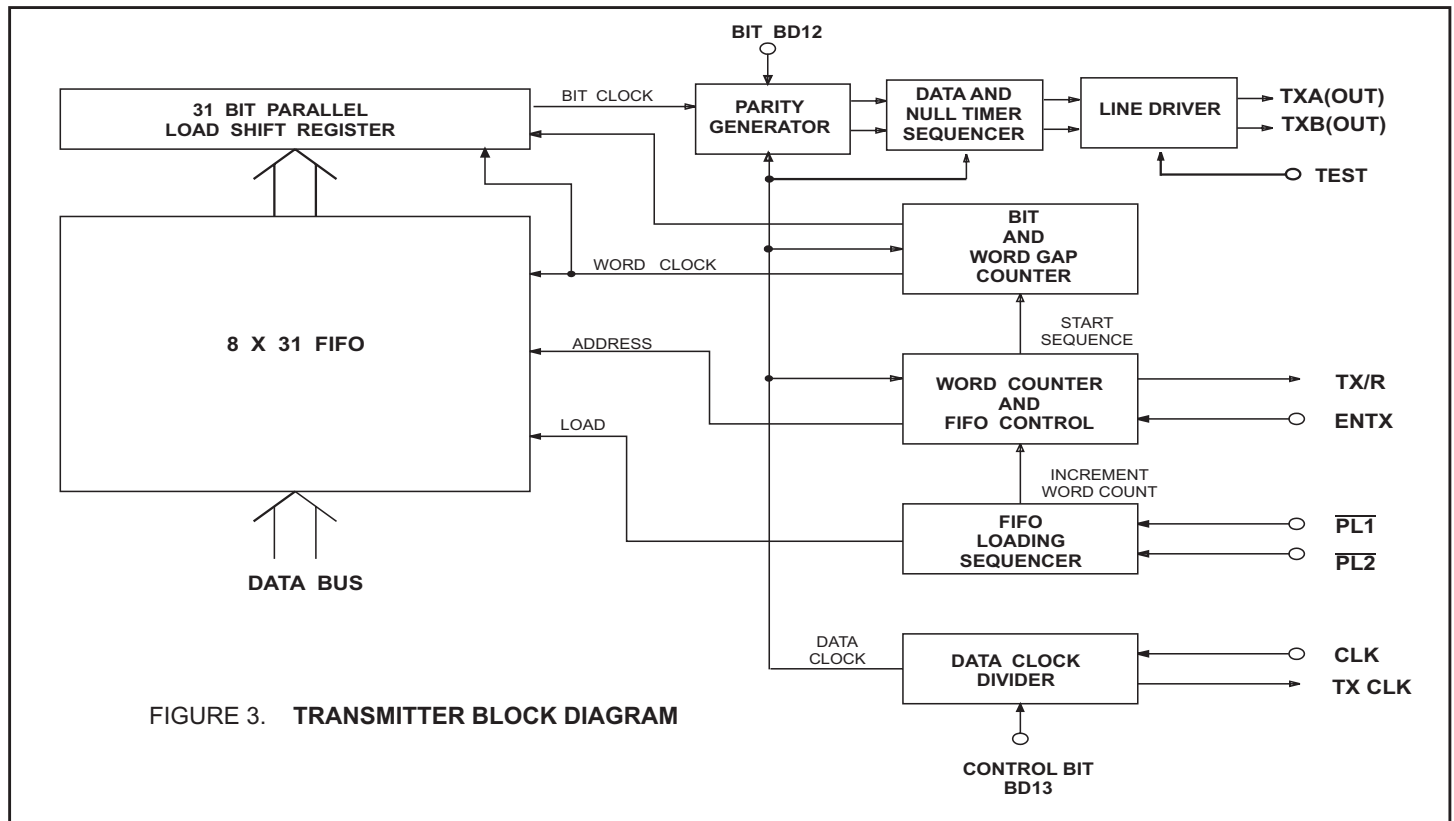

FIGURE 3. TRANSMITTER BLOCK DIAGRAM

FUNCTIONAL DESCRIPTION (cont.)

LINE DRIVER OPERATION

The line driver in the HI-8599 is designed to directly drive the ARINC 429 bus. The two ARINC outputs (TXA(OUT) and TXB(OUT)) provide a differential voltage to produce a +10 volt One, a -10 volt Zero, and a 0 volt Null. Setting Control Register bit 13 to zero causes a slope of $1.5 \mu\text{s}$ on the ARINC outputs. A one in Control Register bit 13 causes a slope of $10 \mu\text{s}$. Timing is set by on-chip resistor and capacitor and tested to be within ARINC requirements. No additional hardware is required to control the slope. The HI-8599 has 10 ohms in series with each line driver output, and is for applications where additional external series resistance is required, such as lightning protection.

REPEATER OPERATION

Repeater mode of operation allows a data word that has been received by the HI-8599 to be placed directly into its FIFO for transmission. Repeater operation is similar to normal receiver operation. In normal operation, either byte of a received data word may be read from the receiver latches first by use of SEL input. During repeater operation however, the lower byte of the data word must be read first. This is necessary because, as the data is being read, it is also being loaded into the FIFO and the transmitter FIFO is always loaded with the lower byte of the data word first. Signal flow for repeater operation is shown in the Timing Diagrams section.

HI-8599-10

The "-10" version of the HI-8599 product require a 10 Kohm resistor to be placed in series with each ARINC input without affecting the ARINC input thresholds. This option is especially useful in applications where external lightning protection is required.

Each ARINC input pin must be connected to the ARINC bus through a 10 Kohm resistor in order for the chip to properly detect the correct ARINC levels. The typical 10 volt differential signal is translated and input to a window comparator and latch. The comparator levels are set so that with the external 10 Kohm resistors, they are just below the standard 6.5 volt minimum ARINC data threshold and just above the 2.5 volt maximum ARINC null threshold.

Please refer to the Holt AN-300 Application Note for additional information and recommendations on lightning protection of Holt line drivers and line receivers.

POWER SUPPLY SEQUENCING

The power supplies should be controlled to prevent large currents during supply turn-on and turn-off. The recommended sequence is V+ followed by Vcc, always ensuring that V+ is the most positive supply. The V- supply is not critical and can be asserted at any time.

TIMING DIAGRAMS

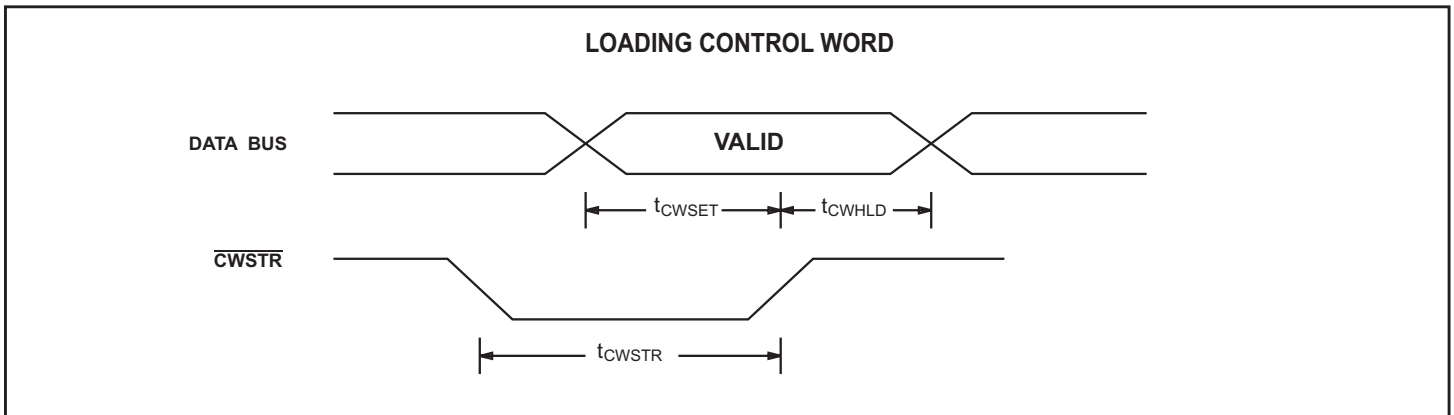
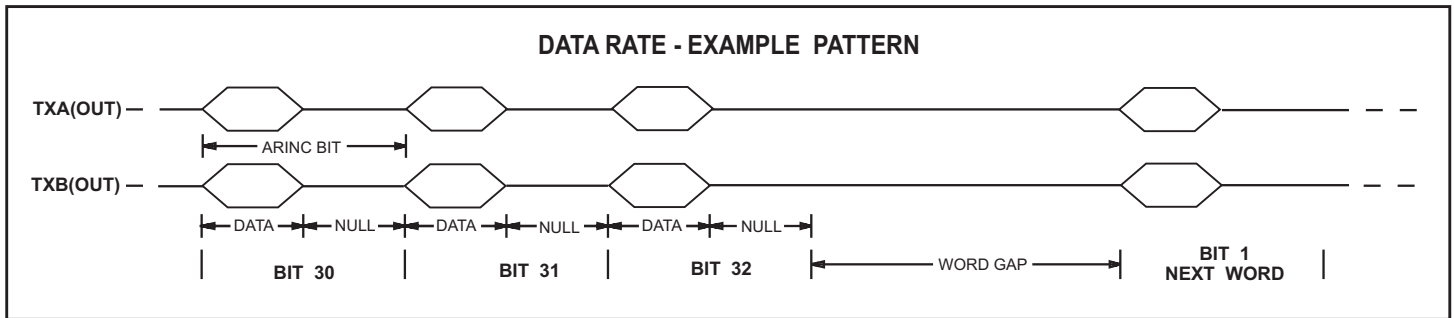

TIMING DIAGRAMS (cont.)

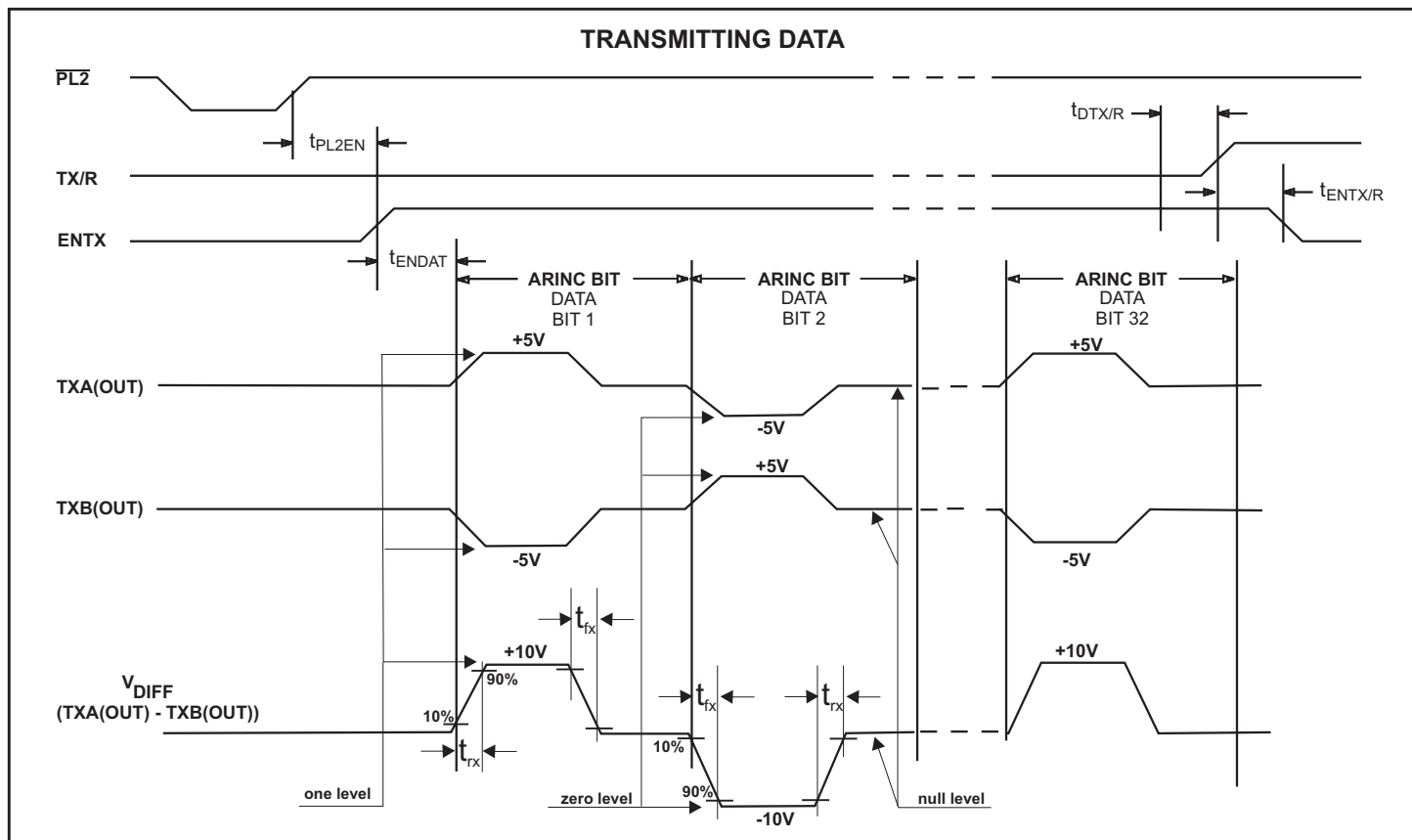
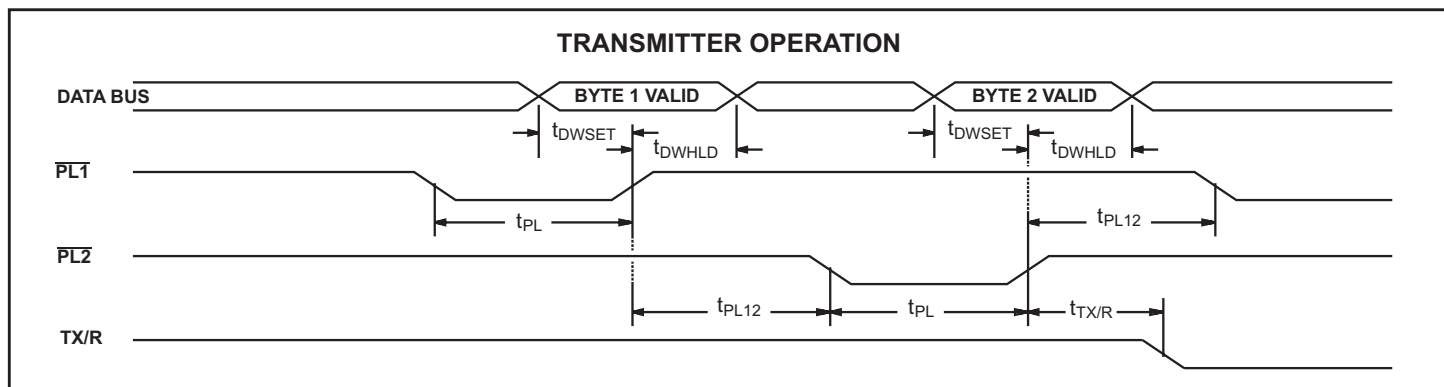
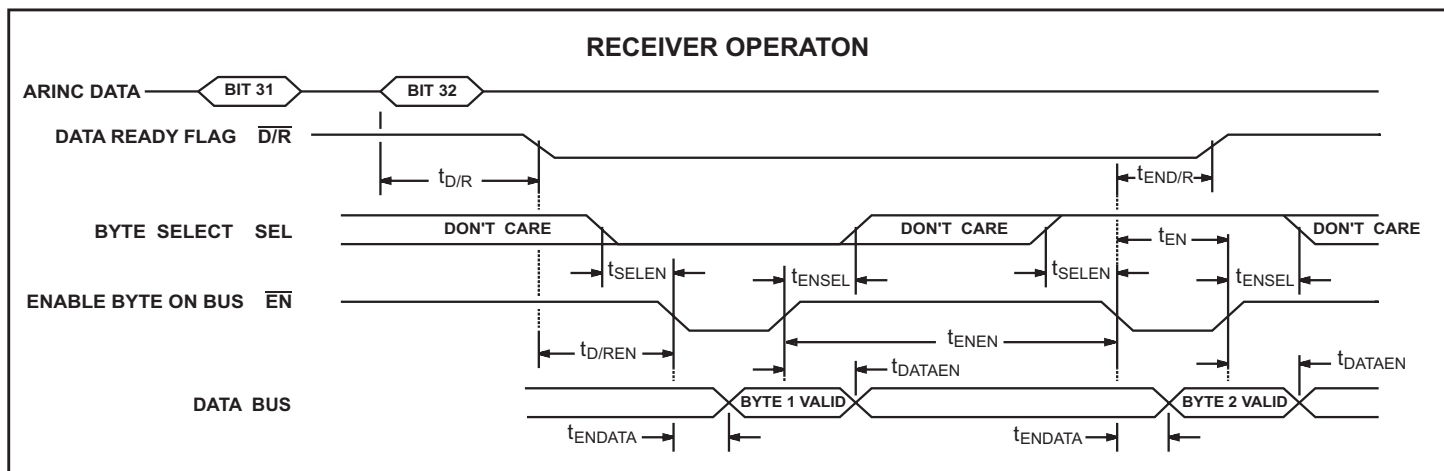

TIMING DIAGRAMS (cont.)

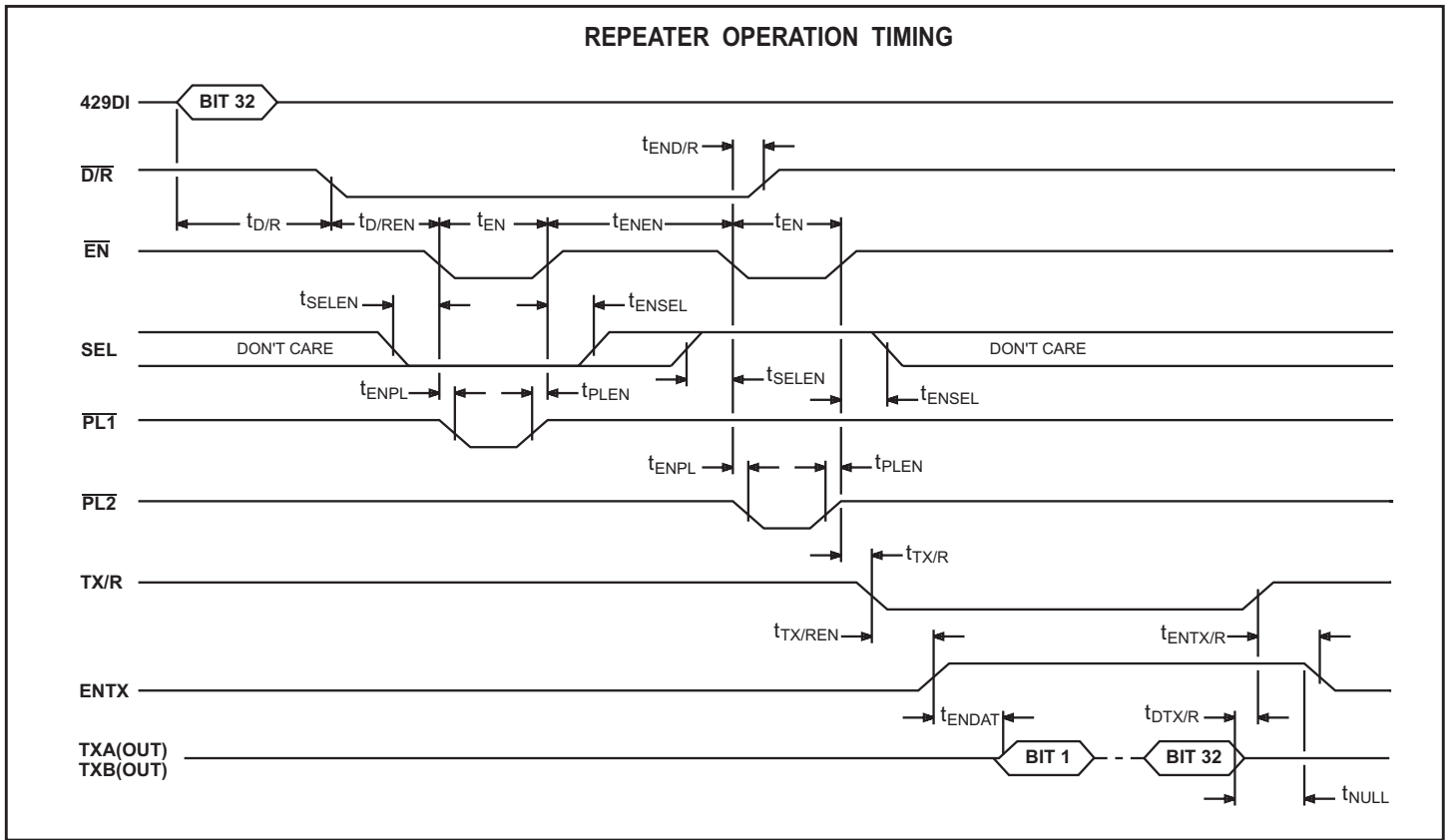

ABSOLUTE MAXIMUM RATINGS

| | |
|---|---|
| Supply Voltages Vcc -0.3V to +7V V+ +12.5V V- -12.5V | Power Dissipation at 25°C Plastic PLCC/PQFP 1.5 W, derate 10mW/°C Ceramic J-LEAD CERQUAD 1.0 W, derate 7mW/°C |
| Voltage at ARINC inputs -29V to +29V | DC Current Drain per pin ±10mA |
| Voltage at any other pin -0.3V to Vcc +0.3V | Storage Temperature Range: -65°C to +150°C |
| Soldering Temperature (Leads) 280°C for 10 seconds (Package) 220°C | Operating Temperature Range: (Industrial) -40°C to +85°C (Military) -55°C to +125°C |

NOTE: Stresses above those listed under "Absolute Maximum Ratings" may cause permanent damage to the device. These are stress ratings only. Functional operation of the device at these or any other conditions above those indicated in the operational sections of the specifications is not implied. Exposure to absolute maximum rating conditions for extended periods may affect device reliability.

DC ELECTRICAL CHARACTERISTICS

Vcc = 5V ±5%, V+ = 10V, V- = -10V, GND = 0V, TA = Operating Temperature Range (unless otherwise specified).

| PARAMETER | SYMBOL | CONDITIONS | LIMITS | | | UNIT | |
|--|--|--|---|----------------------|--------------------|---------------------|----------------|
| | | | MIN | TYP | MAX | | |
| ARINC INPUTS | | | | | | | |
| Differential Input Voltage: (429D11(A) to 429D11(B); 429D12(A) to 429D12(B)) | ONE ZERO NULL | V _{IH} V _{IL} V _{NUL} | Common mode voltage less than ±4V with respect to GND | 6.5 -13.0 -2.5 | 10.0 -10.0 0 | 13.0 -6.5 2.5 | V V V |
| Input Resistance: | Differential To GND To Vcc | R _I R _G R _H | | 12 12 12 | 27 27 | | KΩ KΩ KΩ |
| Input Current: | Input Sink Input Source | I _{IH} I _{IL} | | -450 | | 200 | μA μA |
| Input Capacitance:(Guaranteed but not tested) (429D11(A), 429D11(B), 429D12(A) & 429D12(B)) | Differential To GND To Vcc | C _I C _G C _H | | | | 20 20 20 | pF pF pF |
| BI-DIRECTIONAL INPUTS | | | | | | | |
| Input Voltage: | Input Voltage HI Input Voltage LO | V _{IH} V _{IL} | | 2.1 | | 0.7 | V V |
| Input Current: | Input Sink Input Source Pull-down Current (TEST Pin) | I _{IH} I _{IL} I _{PD} | | -1.5 50 | | 1.5 150 | μA μA μA |
| OTHER INPUTS | | | | | | | |
| Input Voltage: | Input Voltage HI Input Voltage LO | V _{IH} V _{IL} | | 3.5 | | 0.7 | V V |
| Input Current: | Input Sink | I _{IH} | | | | 10 | μA |

DC ELECTRICAL CHARACTERISTICS (cont.)

V_{CC} = 5V ±5%, V₊ = 10V, V₋ = -10V, GND = 0V, TA = Operating Temperature Range (unless otherwise specified).

| PARAMETER | SYMBOL | CONDITIONS | LIMITS | | | UNIT |
|---|--|--|---------------|------|--------------|----------|
| | | | MIN | TYP | MAX | |
| ARINC OUTPUTS | | | | | | |
| ARINC output voltage One or zero Null | V _{DOUT} V _{NOUT} | no load and magnitude at pin " " " " " " | 4.50 -0.25 | 5.00 | 5.50 0.25 | V V |
| ARINC output current | I _{OUT} | | 80 | | | mA |
| OTHER OUTPUTS | | | | | | |
| Output Voltage: Logic "1" Output Voltage Logic "0" Output Voltage | V _{OH} V _{OL} | I _{OH} = -1.5mA I _{OL} = 2.6mA | 2.7 | | 0.4 | V V |
| Output Current: (Bi-directional Pins) | I _{OL} I _{OH} | V _{OUT} = 0.4V V _{OUT} = V _{CC} - 0.4V | 3.0 1.1 | | | mA mA |
| Output Current: (All Other Outputs) | I _{OL} I _{OH} | V _{OUT} = 0.4V V _{OUT} = V _{CC} - 0.4V | 2.6 1.1 | | | mA mA |
| Output Capacitance: | C _O | | | 15 | | pF |
| Operating Voltage Range | | | | | | |
| | V _{CC} | | 4.75 | | 5.25 | V |
| | V ₊ | | 9.5 | | 10.5 | V |
| | V ₋ | | -9.5 | | -10.5 | V |
| Operating Supply Current | | | | | | |
| V _{CC} | I _{CC1} | | | | 20 | mA |
| V ₊ | I _{DD1} | | | | 16 | mA |
| V ₋ | I _{EE1} | | | | 16 | mA |

AC ELECTRICAL CHARACTERISTICS

V_{cc} = 5V, V₊ = +10V, V₋ = -10V, GND = 0V, TA = Oper. Temp. Range and f_{clk} = 1MHz ±0.1% with 60/40 duty cycle

| PARAMETER | SYMBOL | LIMITS | | | UNITS | |
|--|---------------------|-----------------|-----|------|-------|----|
| | | MIN | TYP | MAX | | |
| CONTROL WORD TIMING | | | | | | |
| Pulse Width - \overline{CWSTR} | t _{CWSTR} | 80 | | | ns | |
| Setup - DATA BUS Valid to \overline{CWSTR} HIGH | t _{CWSET} | 50 | | | ns | |
| Hold - \overline{CWSTR} HIGH to DATA BUS Hi-Z | t _{CWHLDD} | 10 | | | ns | |
| RECEIVER TIMING | | | | | | |
| Delay - Start ARINC 32nd Bit to $\overline{D/R}$ LOW: High Speed | t _{D/R} | | | 16 | μs | |
| Delay - Start ARINC 32nd Bit to $\overline{D/R}$ LOW: Low Speed | t _{D/R} | | | 128 | μs | |
| Delay - $\overline{D/R}$ LOW to \overline{EN} LOW | t _{D/REN} | 0 | | | ns | |
| Delay - \overline{EN} LOW to $\overline{D/R}$ HIGH | t _{END/R} | | | 200 | ns | |
| Setup - SEL to \overline{EN} LOW | t _{SELEN} | 10 | | | ns | |
| Hold - SEL to \overline{EN} HIGH | t _{ENSEL} | 10 | | | ns | |
| Delay - \overline{EN} LOW to DATA BUS Valid | t _{ENDATA} | | 50 | 100 | ns | |
| Delay - \overline{EN} HIGH to DATA BUS Hi-Z | t _{DATAEN} | | | 30 | ns | |
| Pulse Width - $\overline{EN1}$ or $\overline{EN2}$ | t _{EN} | 80 | | | ns | |
| Spacing - \overline{EN} HIGH to next \overline{EN} LOW | t _{ENEN} | 50 | | | ns | |
| FIFO TIMING | | | | | | |
| Pulse Width - $\overline{PL1}$ or $\overline{PL2}$ | t _{PL} | 80 | | | ns | |
| Setup - DATA BUS Valid to \overline{PL} HIGH | t _{DWSET} | 50 | | | ns | |
| Hold - \overline{PL} HIGH to DATA BUS Hi-Z | t _{DWHLDD} | 10 | | | ns | |
| Spacing - $\overline{PL1}$ or $\overline{PL2}$ | t _{PL12} | 0 | | | ns | |
| Delay - $\overline{PL2}$ HIGH to TX/R LOW | t _{TX/R} | | | 840 | ns | |
| TRANSMISSION TIMING | | | | | | |
| Spacing - $\overline{PL2}$ HIGH to ENTX HIGH | t _{PL2EN} | 0 | | | μs | |
| Delay - 32nd ARINC Bit to TX/R HIGH | t _{DTX/R} | | | 50 | ns | |
| Spacing - TX/R HIGH to ENTX LOW | t _{ENTX/R} | 0 | | | ns | |
| LINE DRIVER OUTPUT TIMING | | | | | | |
| Delay - ENTX HIGH to TXA(OUT) or TXB(OUT): High Speed | t _{ENDAT} | | | 25 | μs | |
| Delay - ENTX HIGH to TXA(OUT) or TXB(OUT): Low Speed | t _{ENDAT} | | | 200 | μs | |
| Line driver transition differential times: | | | | | | |
| (High Speed) | high to low | t _{fx} | 1.0 | 1.5 | 2.0 | μs |
| | low to high | t _{rx} | 1.0 | 1.5 | 2.0 | μs |
| (Low Speed) | high to low | t _{fx} | 5.0 | 10 | 15 | μs |
| | low to high | t _{rx} | 5.0 | 10 | 15 | μs |
| REPEATER OPERATION TIMING | | | | | | |
| Delay - \overline{EN} LOW to \overline{PL} LOW | t _{ENPL} | 0 | | | ns | |
| Hold - \overline{PL} HIGH to \overline{EN} HIGH | t _{PLEN} | 0 | | | ns | |
| Delay - TX/R LOW to ENTX HIGH | t _{TX/REN} | 0 | | | ns | |
| MASTER RESET PULSE WIDTH | | | | | | |
| | t _{MR} | 400 | | | ns | |
| ARINC DATA RATE AND BIT TIMING | | | | | | |
| | | | | ± 1% | | |

ORDERING INFORMATION

HI - 8599PQ x - xx

| PART NUMBER | INPUT SERIES RESISTANCE | |
|----------------|-------------------------|---------------------|
| | BUILT-IN | REQUIRED EXTERNALLY |
| No dash number | 35 Kohm | 0 |
| -10 | 25 Kohm | 10 Kohm |

| PART NUMBER | TEMPERATURE RANGE | FLOW | BURN IN |
|-------------|-------------------|------|---------|
| I | -40°C TO +85°C | I | NO |
| T | -55°C TO +125°C | T | NO |

HI-8599 PACKAGE DIMENSIONS

Inches (millimeters)

44-PIN PLASTIC QUAD FLAT PACK (PQFP)

Package Type: 44PQS

