

### GENERAL DESCRIPTION

The HI-8020 & HI-8120 high voltage display drivers are functional replacements for the AMI S5420 and Micrel MIC8013/8014 series. These CMOS products are designed to drive liquid crystal displays by converting 5 volt serial data to parallel segment and backplane waveforms with amplitudes up to 30 volts. The HI-8020 & HI-8120 differ from the HI-8010 by only the shift register clock and chip select gating logic. The HI-8020 has TTL logic inputs whereas the HI-8120 has CMOS logic inputs.

Both devices can drive up to 38 segments and have 3 possible shift register data taps to provide options to cascade devices for larger displays. Data is clocked into a 38 stage shift register and parallel latched before the output translators by a Load input.

The HI-8020 & HI-8120 are available in ceramic leadless chip carriers and plastic PLCC packages.

### FEATURES

- 5 volt input translated to 30 volts or less
- Pin-out adaptable to drive 30, 32 or 38 LCD segments
- RC oscillator or high voltage (BP) clock input
- TTL compatible inputs (HI-8020 only)
- CMOS compatible inputs (HI-8120 only)
- Low power consumption
- Industrial (-40°C to +85°C) & Military (-55°C to +125°C) temperature ranges
- Pin for pin compatible with the Micrel MIC8010/8011 series and the AMI S4520 series drivers
- Cascadable
- Military level processing available

### APPLICATIONS

- Dichroic Liquid Crystal Displays
- Standard Liquid Crystal Displays
- Vacuum Fluorescent Displays
- MEMS Drivers

### PIN CONFIGURATION (Top View)

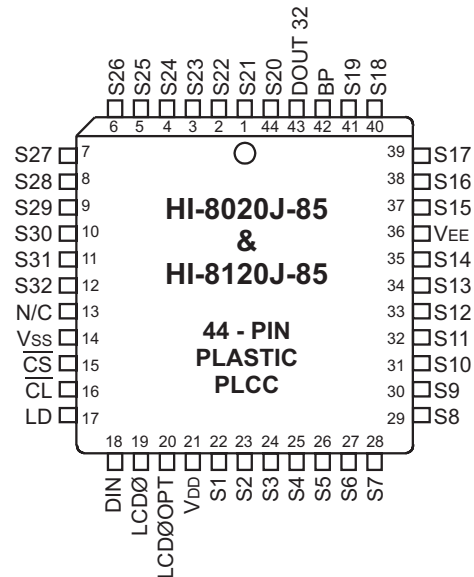

(See page 4 for additional package pin configurations)

### FUNCTIONAL BLOCK DIAGRAM

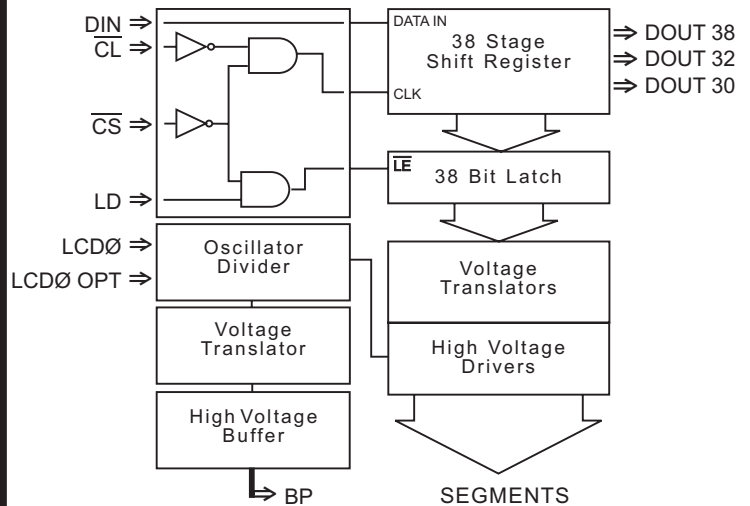

## FUNCTIONAL DESCRIPTION

Whenever a Logic "0" is applied to the Chip Select ( $\overline{CS}$ ) input, one bit of data is clocked into the shift register from the serial data input (DIN) with each negative transition of the Clock ( $\overline{CL}$ ) input. A Logic "1" present at the Load (LD) input will cause a parallel transfer of data from the shift register to the data latch. If the Load (LD) input is held high while data is clocked into the shift register, the latch will be transparent. All four logic inputs are TTL compatible on the HI-8020 and CMOS compatible on the HI-8120.

To display segments, a Logic "1" is stored in the appropriate shift register bit position, and the segment output is out-of-phase with the backplane.

The backplane output functions in 1 of 2 modes; externally driven or self-oscillating. When the LCD $\emptyset$  input is externally driven with the LCD $\emptyset$ OPT input open circuit (Figure 2), the backplane output will be in-phase with LCD $\emptyset$ . Utilizing the self-oscillating mode, inputs LCD $\emptyset$  and LCD $\emptyset$ OPT are tied together and connected to an RC circuit (Figure 3). A 150K $\Omega$  resistor with a 470pF capacitor generates an approximate backplane frequency of 100Hz. The LCD $\emptyset$ /LCD $\emptyset$ OPT oscillator frequency is divided by 256 to determine the backplane output frequency. The resistor value (R) must be at least 30K $\Omega$  for proper self-oscillator operation.

For displays having a number of segments greater than 38, two or more of the display drivers may be cascaded together by connecting the serial data output (DOUT) from the first driver, to the serial data input (DIN) of the following driver, etc.(See Figures 2 & 3). Data out (DOUT) will change state

on the rising edge of the Clock ( $\overline{CL}$ ). Clock ( $\overline{CL}$ ), Load (LD) and Chip Select ( $\overline{CS}$ ) should be tied in common with each other, respectively, between all cascaded display drivers.

## INTERNAL OSCILLATOR CIRCUIT

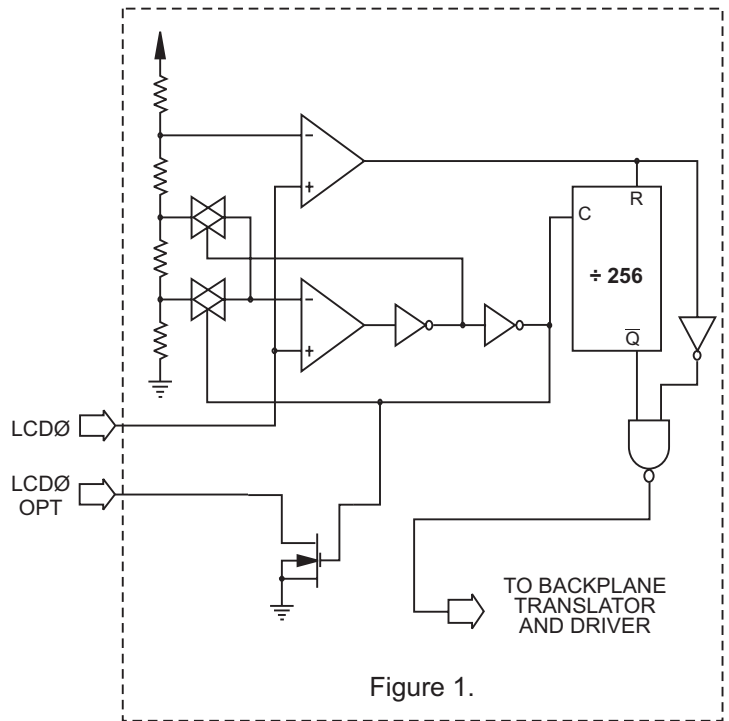
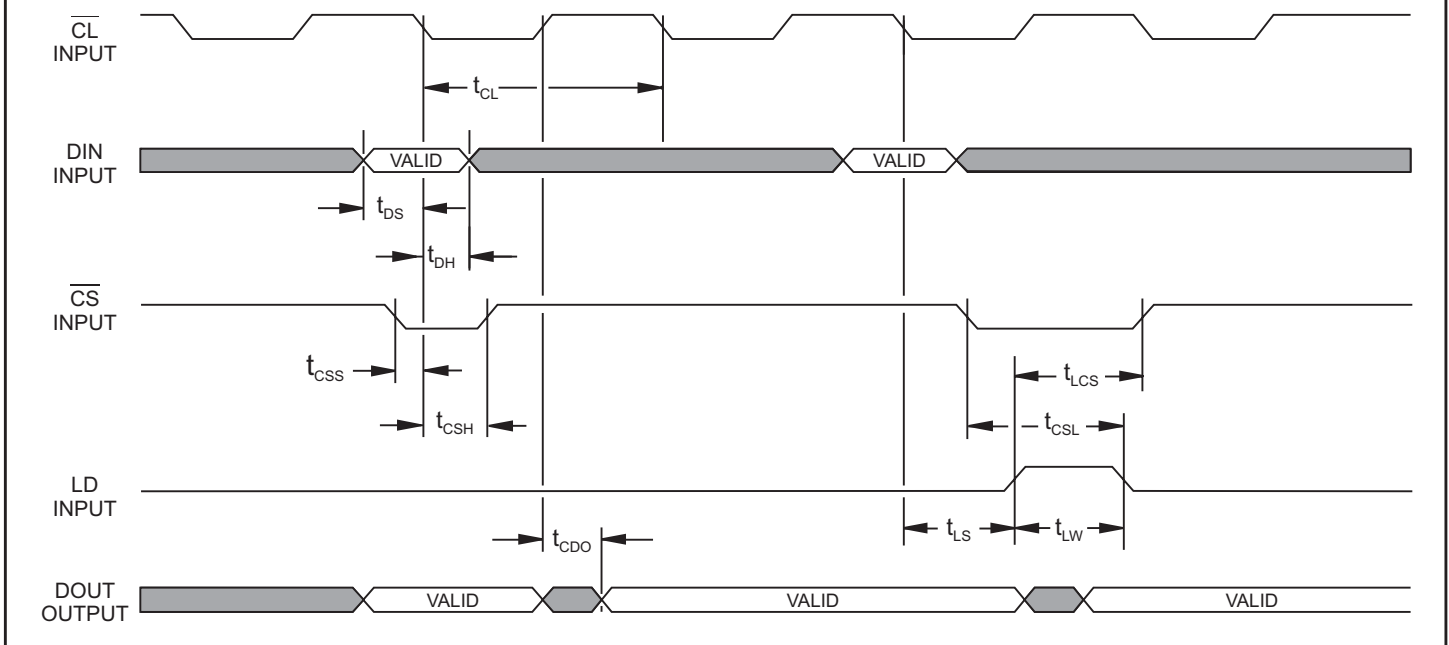

Figure 1.

## TIMING DIAGRAM



## ABSOLUTE MAXIMUM RATINGS

Voltages referenced to VSS = 0V

Supply Voltage	VDD..... 0V to 7V VEE.....VDD-35V to 0V	Power Dissipation.....300 mW
Voltage at any input, except LCDØ	..-0.3 to VDD+0.3V	Operating Temperature Range - Industrial.....-40° to +85°C
Voltage at LCDØ input	.....VDD-35 to VDD+0.3V	Operating Temperature Range - Hi-Temp/Mil...-55° to +125°C
DC Current any input pin	.....10 mA	Storage Temperature Range.....-65° to +150°C

NOTE: Stresses above those listed under "Absolute Maximum Ratings" may cause permanent damage to the device. These are stress ratings only. Functional operation of the device at these or any other conditions above those indicated in the operational sections of the specifications is not implied. Exposure to absolute maximum rating conditions for extended periods may affect device reliability.

## DC ELECTRICAL CHARACTERISTICS

VDD = 5V, VEE = -25V, VSS = 0V, TA = Operating Temperature Range (unless otherwise specified).

PARAMETER	SYMBOL	CONDITION	MIN	TYP	MAX	UNITS
Operating Voltage	VDD		3.0		7.0	V
Supply Current	IDD	Static, No Load			225	µA
	IEE	Static, No Load fBP=100Hz			150	µA
Input Low Voltage, HI-8020 (except LCDØ)	VILTTL		0		0.8	V
Input High Voltage, HI-8020 (except LCDØ)	VIHTTL		2		VDD	V
Input Low Voltage, HI-8120 (except LCDØ)	VILCMOS		0		0.3 VDD	V
Input High Voltage, HI-8120 (except LCDØ)	VIHCMOS		0.7 VDD		VDD	V
Input Low Voltage (LCDØ)	VILX		VEE		3	V
Input High Voltage (LCDØ)	VIHX		3.5		VDD	V
Input Current	IIN	VIN = 0 to 5V			1	µA
Input Capacitance (not tested)	CI				5	pF
Segment Output Impedance	RSEG	IL = 10µA		10	15	KΩ
Backplane Output Impedance	RBP	IL = 10µA		450	600	Ω
Data Out Current:	IDOH	Source Current, VOH = 4.5V			-0.6	mA
	IDOL	Sink Current, VOL = 0.5V	0.6			mA

## AC ELECTRICAL CHARACTERISTICS

VDD = 5V, VEE = -25V, VSS = 0V, TA = Operating Temperature Range (unless otherwise specified).

PARAMETER	SYMBOL	VDD	MIN	TYP	MAX	UNITS
Clock Period	tCL	5V	1200			ns
Clock Pulse Width	tcw	5V	520			ns
Data In - Setup	tDS	5V	50			ns
Data In - Hold	tDH	5V	400			ns
Chip Select - Setup to Clock	tcSS	5V	200			ns
Chip Select - Hold to Clock	tCSH	5V	450			ns
Load - Setup to Clock	tLS	5V	500			ns
Chip Select - Setup to Load	tCSL	5V	300			ns
Load Pulse Width	tLW	5V	500			ns
Chip Select - Hold to Load	tLCS	5V	300			ns
Data Out Valid, from Clock	tcDO	5V			800	ns

### CASCADING - EXT. OSCILLATOR

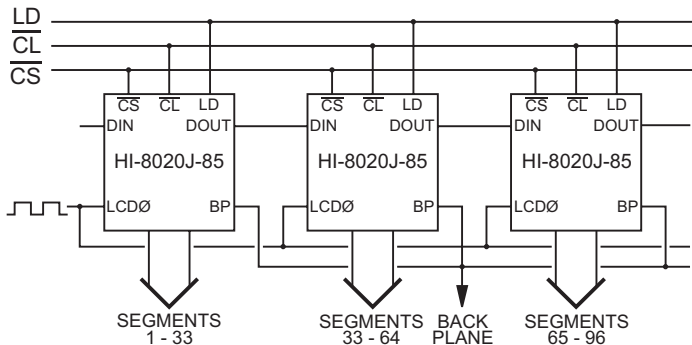

Figure 2

### CASCADING - RC OSCILLATOR

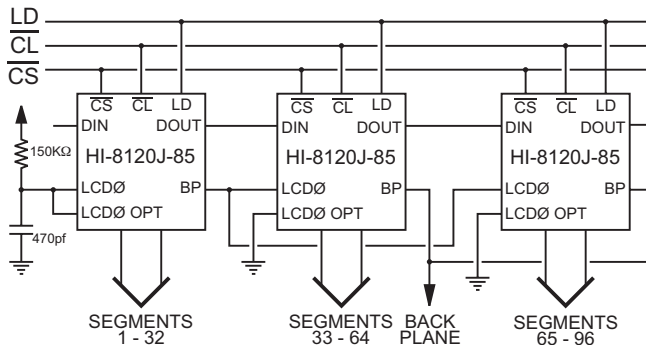

Figure 3

### PIN DESCRIPTIONS

SYMBOL	FUNCTION	DESCRIPTION
VSS	POWER	0 Volts
CS	INPUT	Logic input Chip select
CL	INPUT	Logic input Clocks shift register on negative edge and DOUT pins on positive edge
LD	INPUT	Logic input Segment outputs equal shift register data if Load is high
DIN	INPUT	Logic input Shift register data input
LCD0	INPUT	Analog input Display clock input and is always bonded out. Can swing from VEE to VDD
LCD0OPT	OUTPUT	Analog output Bonded out only if an RC oscillator is required
VDD	POWER	5 Volts
VEE	POWER	0 Volts to -30 Volts
DOUT	OUTPUT	Logic output Selected pinout can provide shift register taps at positions 30, 32, 34, or 38
BP	OUTPUT	Display drive output Low resistance drive for the backplane and swings from VDD to VEE
Segments	OUTPUT	Display drive output High resistance drive for each segment and swings from VDD to VEE

### ADDITIONAL HI-8020/HI-8120 PIN CONFIGURATIONS

(See page 1 for the 44-Pin Plastic PLCC)

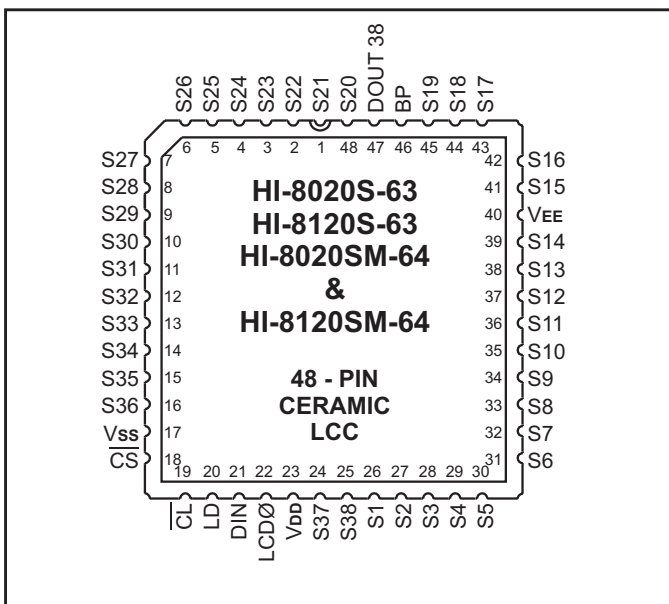
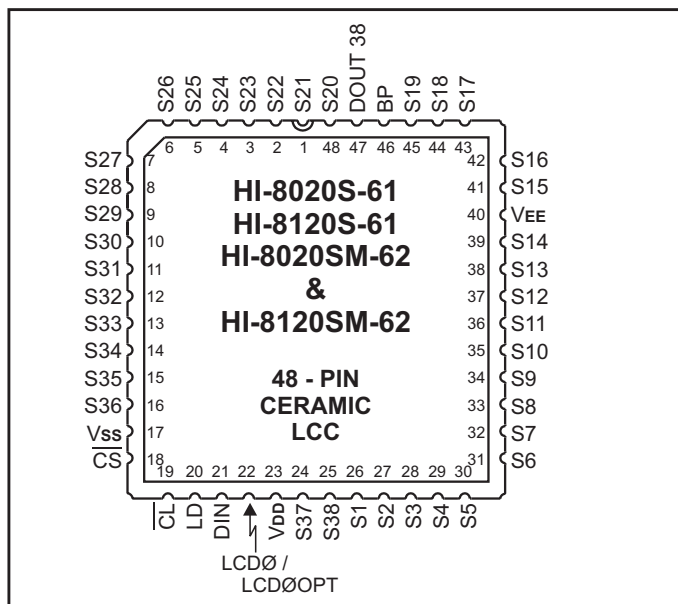

**ORDERING INFORMATION**

**HI - 8XXX J X - 85 (44-pin Plastic J Lead)**

PART NUMBER	LEAD FINISH
Blank	Tin / Lead (Sn / Pb) Solder
F	100% Matte Tin (Pb-free, RoHS compliant)

PART NUMBER	INPUT LOGIC	NUMBER OF SEGMENTS	MASTER/ SLAVE	TEMPERATURE RANGE	FLOW	BURN IN
8020	TTL	32	BOTH	-40°C TO +85°C	I	NO
8120	CMOS	32	BOTH	-40°C TO +85°C	I	NO

**HI - 8XXX XX - XX (48-pin Ceramic Leadless Chip Carrier)**

PART NUMBER	MASTER/ SLAVE	TEMPERATURE RANGE	FLOW	BURN IN	LEAD FINISH
S - 61	MASTER	-40°C TO +85°C	I	NO	Gold (Pb-free, RoHS compliant)
SM - 62	MASTER	-55°C TO +125°C	M	YES	Tin / Lead (Sn / Pb) Solder
S - 63	SLAVE	-40°C TO +85°C	I	NO	Gold (Pb-free, RoHS compliant)
SM - 64	SLAVE	-55°C TO +125°C	M	YES	Tin / Lead (Sn / Pb) Solder

PART NUMBER	INPUT LOGIC	NUMBER OF SEGMENTS
8020	TTL	38
8120	CMOS	38

## SEMI-CUSTOM PACKAGING

The above part numbers represent the standard configurations of the HI-8020 & HI-8120 products. They can also be provided with a varied number of output segments (30, 32 and 38), with either industrial or military screening and in a wide variety of packages. Listed below are currently available packages. Please contact the Holt Sales Department for your specific requirements.

PACKAGE DESCRIPTION	# LEADS
PLASTIC DUAL-IN-LINE (PDIP)	40
	48
PLASTIC QUAD FLAT PACK (PQFP)	52
PLASTIC J-LEAD CHIP CARRIER (PLCC)	44
CERAMIC DUAL-IN-LINE (CDIP)	40
	48
CERAMIC LEADLESS CHIP CARRIER (LCC)	40
	48
CERAMIC J-LEAD CHIP CARRIER	44
	48
CERAMIC LEADED CHIP CARRIER	40
	48

**44-PIN PLASTIC PLCC**

Package Type: 44J

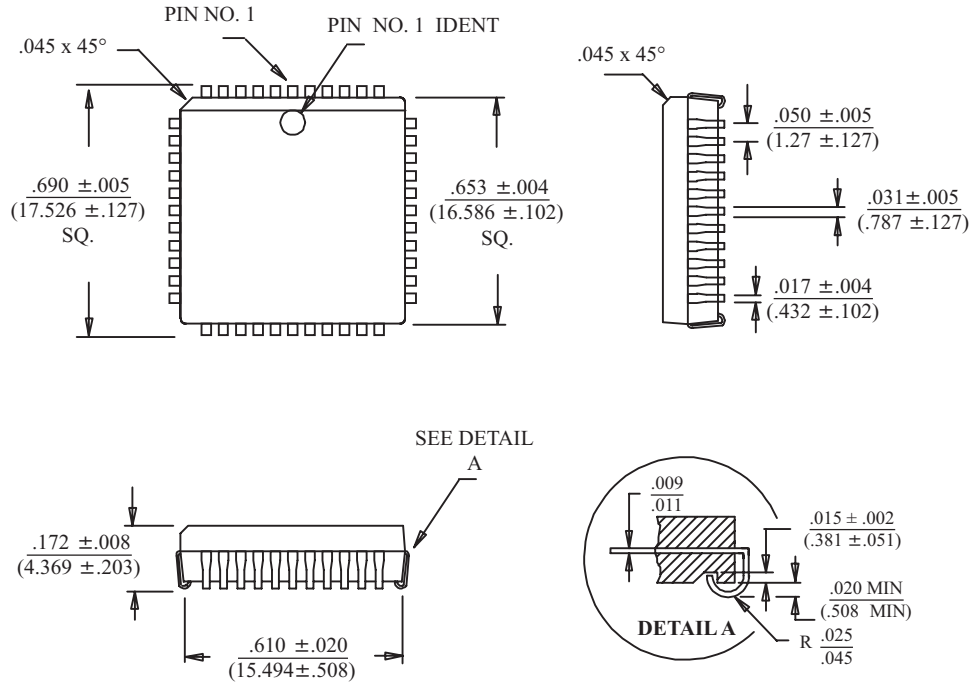

**48-PIN CERAMIC LEADLESS CHIP CARRIER**

Package Type: 48S

