HA13565F

Three-Phase Brushless DC Motor Driver IC

HITACHI

ADE-207-226A (Z)
2nd. Edition
April 1997

Description

HA13565F is a 3-phase brushless DC motor driver IC with digital speed control. It is developed for direct drive of the spindle motor of 5V floppy disk drives. It has the following functions and features.

Functions

- 3 sensor 1.0A/phase, 3-phase drive circuit
- Digital speed control circuit
- Sensorless index circuit
- Current limiter circuit
- Over-temperature shutdown circuit (OTSD)
- Circuit for switching between 300 and 360rpm speeds

Features

- Low saturation voltage 0.5V Typ (at 0.7A)
- Soft switching drive circuit
- Small surface mount package

Pin Arrangement

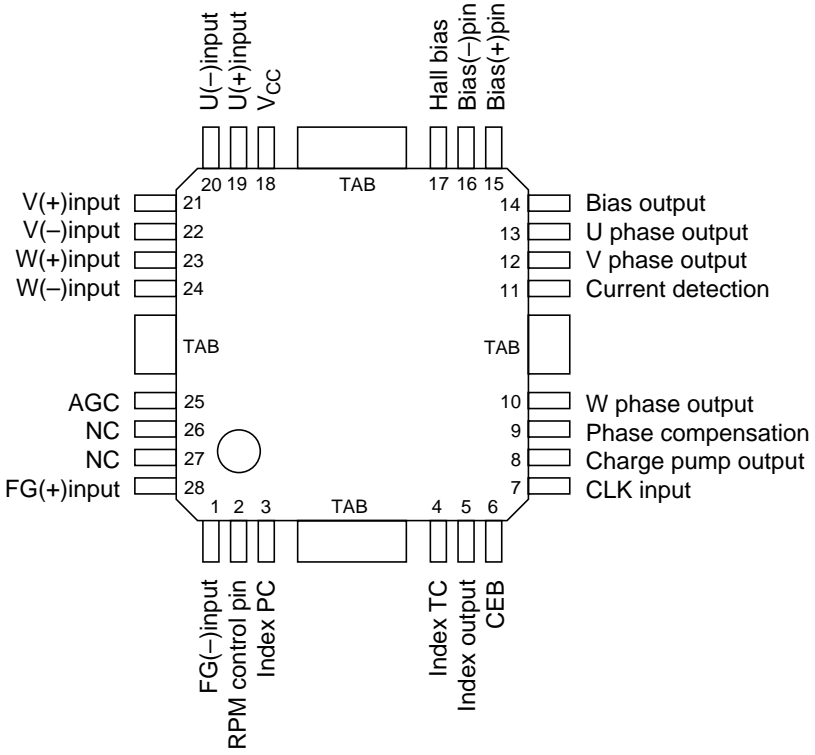

(Top view)

Pin Function

Pin No.	Pin Name	Function
1	FG (–) input	FG amp. (–) input terminal
2	RPM control pin	Control terminal for motor rotation speed “H” → 360 rpm, “L” → 300 rpm
3	Index PC	Connection for the time constant circuit that adjusts the index circuit Vth level.
4	Index TC	Burst setting time constant circuit for index circuit
5	Index output	Index signal output terminal (Open collector)
6	CEB	Chip enable terminal “H”: disable, “L”: enable
7	CLK input	Reference clock input terminal
8	Charge pump output	Connection for the time constant circuit that integrates the speed error signal.
9	Phase compensation	Connection for the phase compensation capacitor that stabilizes the operation of the control system.
10	W phase output	W phase output
11	Current detection	Output current detection and terminal which is connected with resistor for current limiter.
12	V phase output	V phase output
13	U phase output	U phase output
14	Bias output	Smoothing circuit for the pumped output circuit
15	Bias (+) pin	Output circuit used for bias pumping
16	Bias (–) pin	Input circuit used for bias pumping
17	Hall bias	Hall element bias input
18	V _{cc}	Power supply
19	U phase (+) input	U phase (+) input terminal
20	U phase (–) input	U phase (–) input terminal
21	V phase (+) input	V phase (+) input terminal
22	V phase (–) input	V phase (–) input terminal
23	W phase (+) input	W phase (+) input terminal
24	W phase (–) input	W phase (–) input terminal
25	AGC	Smoothing circuit for hall amplifier output amplitude control
26	NC	No connection
27	NC	No connection
28	FG (–) input	Index amp (+) input terminal

Block Diagram

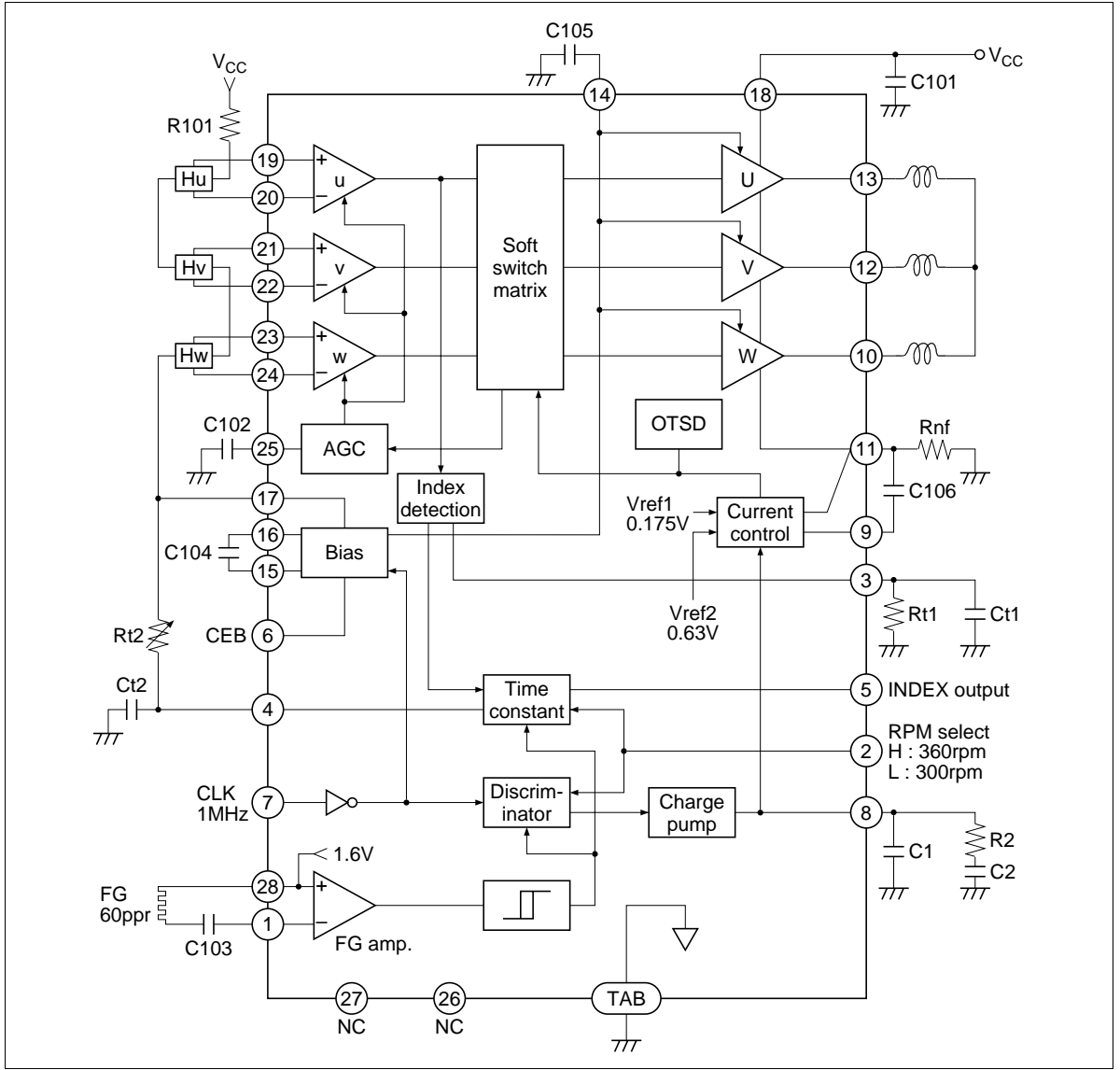

Timing Chart

Hall Amp. Input vs. Output Voltage and Current

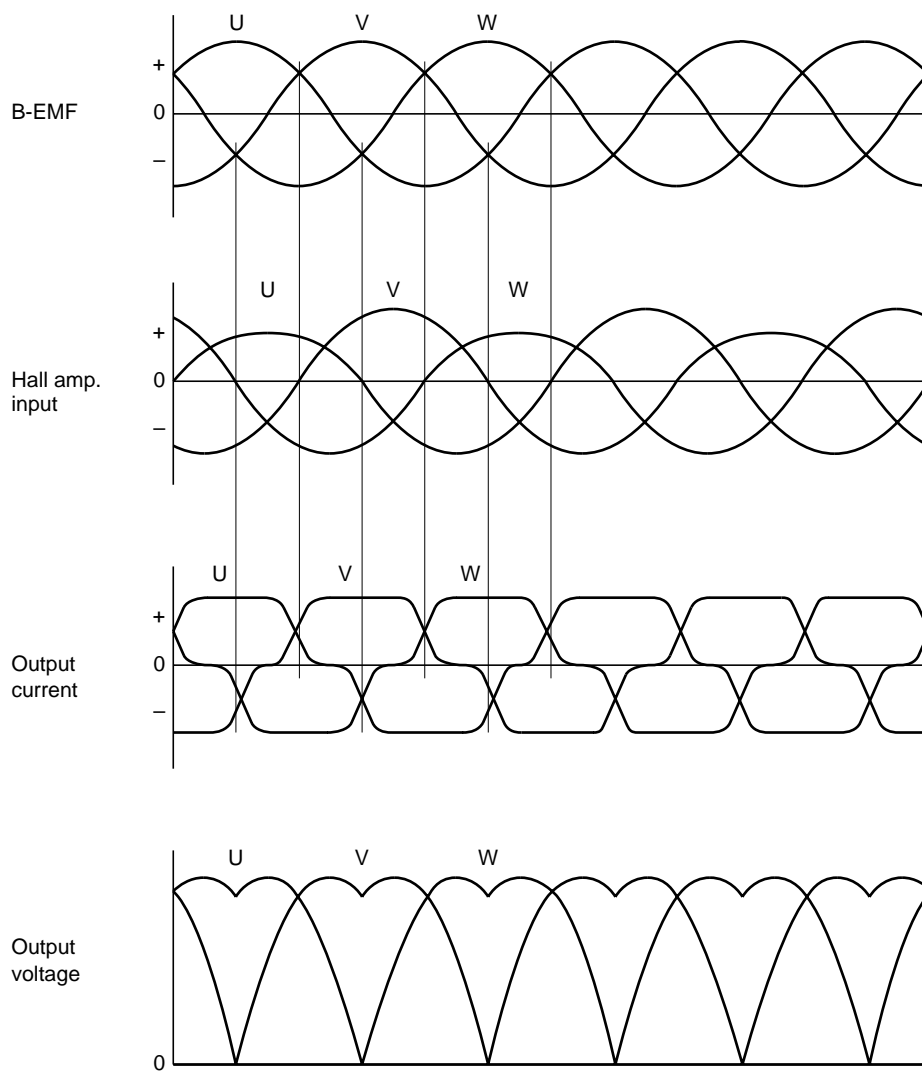

Note: 1. The input waveforms to the hall amp. should be sine waves with a third harmonic content of less than 20%.

Input Detection Timing

RPM Control Pin = L

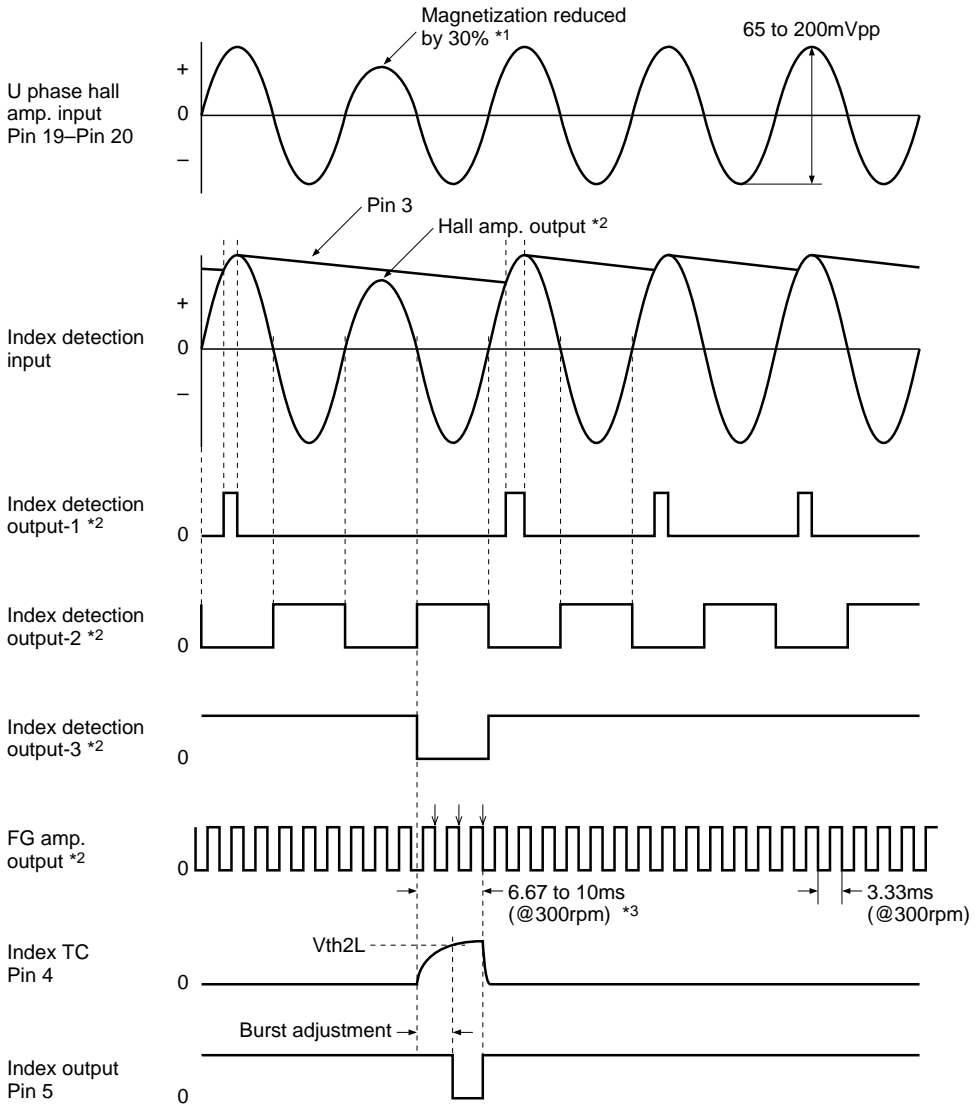

- Note: 1. To generate the index output, one pole of the main magnetization must be reduced so that a difference of at least 30% is assured at the Hall amp. input.
2. These waveforms are shown to indicate the principles of operation, and are not actual measured waveforms.
3. Burst adjustment is started by the fall of the index detector output 3, and then, it ends by the third of fall of FG amp. output.
4. Incorrect pulses may be output immediately after (i.e., within about 200ms of) start-up.
5. If the reduction in the magnetization is inadequate, the index signal may not be generated. Also note that excessive modulation of the Hall amp. input can cause incorrect pulses to be generated.

External Parts

Part No.	Recommended Value	Purpose	Notes
R2	—	Integration constant	1
R101	—	Hall bias	
Rnf	0.33Ω	Spindle current detection and current limitation	2
Rt1	1MΩ	Index circuit Vth adjustment	
Rt2	—	Index burst adjustment	5
C1, C2	—	Integration constants	1
C101	≥0.1μF	Power supply bypass	3
C102	0.047μF	AGC filter	4
C103	0.47μF	FG amp. AC coupling	
C104	≥0.1μF	Bias pumping	
C105	≥0.1μF	Smoothing for bias pumping	6
C106	0.1μF	Control amp. phase compensation	
Ct1	0.1μF	Index circuit Vth adjustment	
Ct2	—	Index burst adjustment	5

Notes: 1. Use the following formulas as a design target when determining the integration constants for actual systems.

$$\omega_0 \leq \frac{2\pi f_{FG}}{20} \quad (\text{rad/S})$$

$$R2 = \frac{1}{9.55} \frac{J \omega_0 N_o Rnf}{K_T Gctl Icp} \quad (\Omega)$$

$$C1 = \frac{1}{\sqrt{10}} \frac{1}{\omega_0 R2} \quad (\text{F})$$

$$C2 = 10 C1 \quad (\text{F})$$

where,

w_o : Time constant of servo loop

f_{FG} : FG frequency (Hz)

N_o : Motor speed (rpm)

J : Motor moment of inertia (kg · cm · s)

K_T : Motor torque constant (kg · cm / A)

Rnf : Current detection resistance (Ω)

$Gctl$: Control gain (see Electrical Characteristics)

Icp : Charge pump output current (see Electrical Characteristics)

2. The current limiter operates according to the following formula.

$$I_{OMAX} = \frac{Vref1}{Rnf} \quad (\text{A})$$

where, $Vref1$ is the current limiter reference voltage (see Electrical Characteristics)

- Place as close to the IC as possible.
- Determine C102 according to the following formulas.

$$C102 \geq \frac{200}{N_O \cdot P} \quad (\mu F)$$

$$C103 \geq \frac{100}{f_{FG}} \quad (\mu F)$$

where,

P = Number of motor poles

- The burst time t1 is defined as follows. (see Electrical Characteristics)

$$t1_H = -Ct2 \times Rt2 \times \ln (1 - V_{th2H} / V_{hb})$$

$$t1_L = -Ct2 \times Rt2 \times \ln (1 - V_{th2L} / V_{hb})$$

where, Rt2 is resistance inter pin 4 and pin 17.

- If the circuit is affected by noise, a large capacitance value should be set.

Absolute Maximum Ratings ($T_a = 25^\circ\text{C}$)

Item	Symbol	Value	Unit	Notes
Power supply voltage	V_{cc}	7.0	V	1
Peak output current	I_{op}	1.0	A	
Normal output current	I_o	0.7	A	
Input voltage	V_i	0 to $V_{cc} + 0.3$	V	2
Power dissipation	P_T	1.5	W	3
Junction temperature	T_j	+150	$^\circ\text{C}$	1
Storage temperature range	T_{stg}	-55 to +125	$^\circ\text{C}$	

Notes: 1. The operating range is as follows.

$$V_{cc} = 4.25 \text{ to } 6.5 \text{ V}$$

$$T_{jop} = 0 \text{ to } +125^\circ\text{C}$$

2. Applied to the logic input pin.

3. Permissible value when $T_{pin} = 113^\circ\text{C}$ and thermal resistance is as follows:

$$\theta_{j-pin} \leq 25^\circ\text{C/W}$$

$$\theta_{j-a1} \leq 55^\circ\text{C/W} \text{ (when mounted on a metal substrate)}$$

$$\theta_{j-a2} \leq 80^\circ\text{C/W} \text{ (when mounted on a glass epoxy substrate)}$$

Electrical Characteristics ($V_{CC} = 5V$, $T_a = 25^\circ C$)

Item	Symbol	Min	Typ	Max	Unit	Test conditions	Applicable Pins	Note
Quiescent current	I_{CCO}	—	—	0.45	mA	CEB=H, $V_{CC}=6.5V$	18	
	I_{CC}	—	9	13	mA	CEB=L, $V_{CC}=6.5V$		
Logic input	Input current (Pin 6)	I_{CEB}	—	—	± 80	μA	$V_{CEB}=0$ to 5V	6
	Input current (Pin 2)	I_{RPM}	—	—	± 100	μA	$V_{RPM}=0$ to 5V	2
	Input current (Pin 7)	I_{CLK}	—	—	± 320	μA	$V_{clk}=0$ to 5V	7
	Input low voltage	V_{IL}	—	—	0.8	V		2, 6, 7
	Input high voltage	V_{IH}	2.0	—	—	V		
Index output	Output low voltage	V_{OL}	—	—	0.4	V	$I_o=2mA$	5
	Leakage current	I_{OH}	—	—	± 10	μA	$V=7.0V$	
Hall amp.	Input resistance	Rhi	—	10	—	k Ω		19 to 24
	Common-mode input voltage	Vh	2.0	—	$V_{CC} - 0.5$	V		
	Differential input voltage	vh	65	—	200	mVpp		
	Index detection threshold	Vth1	80	—	90	%		
Output amp.	Leakage current	I_{CER}	-0.1	—	5	mA	$V_o=7.0V$	10, 12, 13
			-0.1	—	0.1	mA	$V_o=0V$	
	Saturation voltage	V_{sat1}	—	1.15	1.65	V	$I_o=0.7A$	1
			V_{sat2}	—	0.6	0.85	V	

Electrical Characteristics ($V_{CC} = 5V$, $T_a = 25^\circ C$) (cont)

Item		Symbol	Min	Typ	Max	Unit	Test conditions	Applicable Pins	Note
FG amp.	Input voltage range	vfg	2	—	20	mVpp		1, 28	
	Noise margin	nd	—	—	0.5	mVpp	Differential noise		
		nc	—	—	0.5	Vpp	Common noise		
Speed discriminator and charge pump	Number of counts	N	—	1666.5	—	—	RPM control pin=L		
			—	1388.5	—	—	RPM control pin=H		
	Operating frequency	f_{CLK}	0.9	1.0	1.1	MHz		7	
	Leakage current	loff	—	—	± 50	nA	V8=0.8V	8	
	Output current	lcp+	—	10	—	μA	Speed reduction full scale		
lcp-		—	-10	—	μA	Acceleration full scale			
Current control	Threshold voltage	Vref2	—	0.63	—	V	(Control start voltage)	8	2
	Voltage gain	Gctl	—	-10	—	dB		11	
	Current limiter voltage	Vref1	157	175	193	mV	(Rnf=0.33 Ω)		
Index circuit	Index TC input threshold voltage	Vth2L	—	$0.65 \times V_{hb}$	—	V	RPM control pin=L	4	3
		Vth2H	—	$0.58 \times V_{hb}$	—	V	RPM control pin=H		
	Index TC Input current	ltc	—	—	± 2	μA			

Electrical Characteristics ($V_{CC} = 5V$, $T_a = 25^\circ C$) (cont)

Item	Symbol	Min	Typ	Max	Unit	Test conditions	Applicable Pins	Note
Hall bias	Output voltage	vhb	1.9	2.2	2.5	V	$I_h=10mA$, CEB=L	17
	Leakage current	lhoff	—	—	± 10	μA	CEB=H, $V_h=7.0V$, $V_{CC}=7.0V$	
OTSD	Operating temperature	Tsd	125	150	—	$^\circ C$		4
	Hysteresis	Thys	—	25	—	$^\circ C$		

- Notes: 1. Total of sink and source.
 2. Refer to the figure 1. $G_{ct1} = \Delta V_{rnf} / \Delta V_{cp}$.

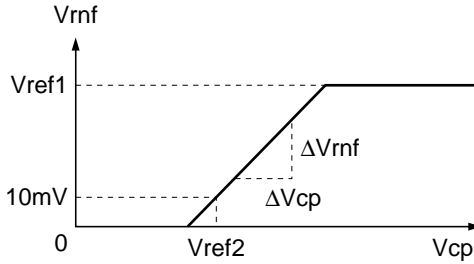
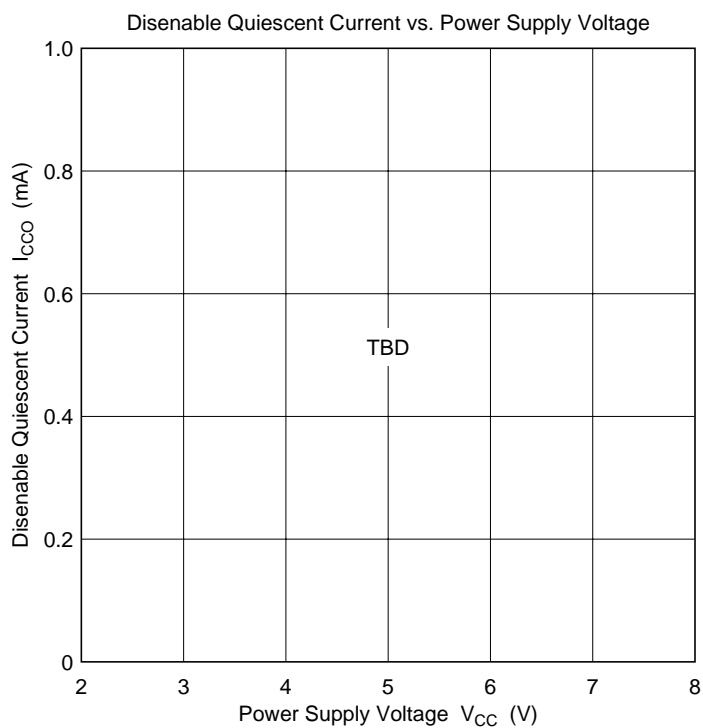
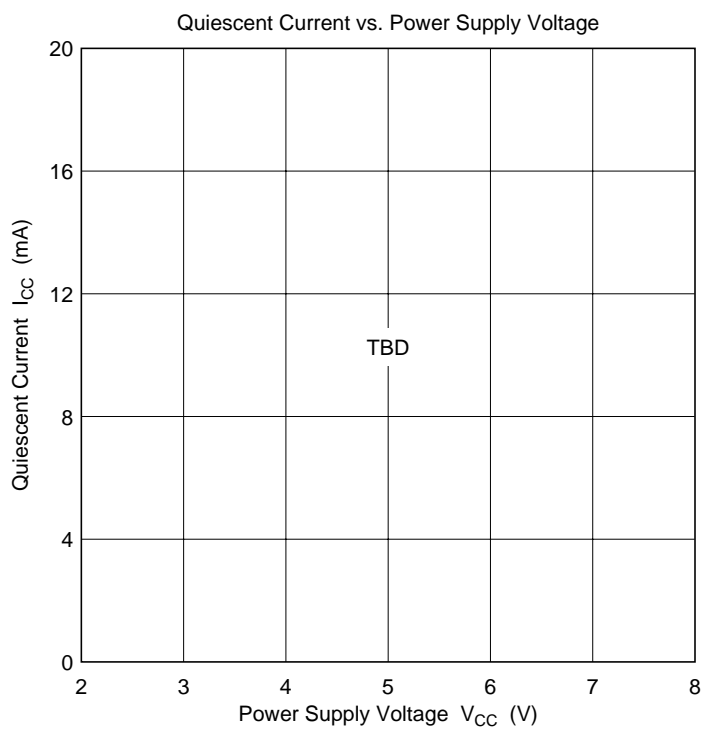
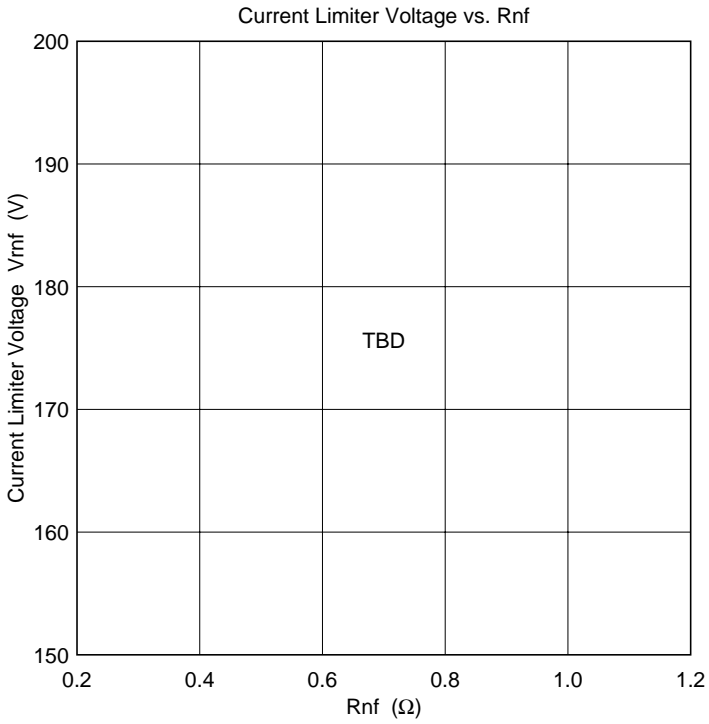
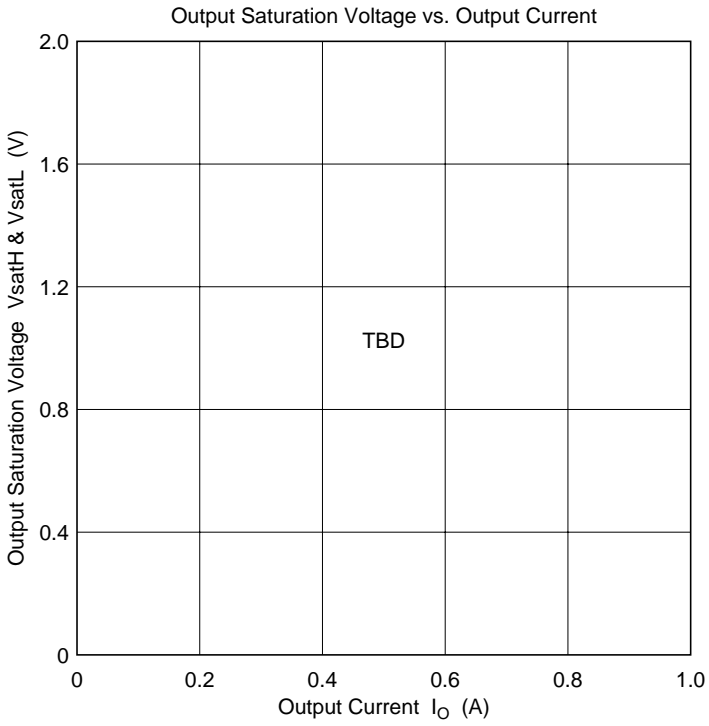

Figure 1

3. Refer to the timing chart.
 4. At the delivery, this characteristics is not tested.

Characteristics Data





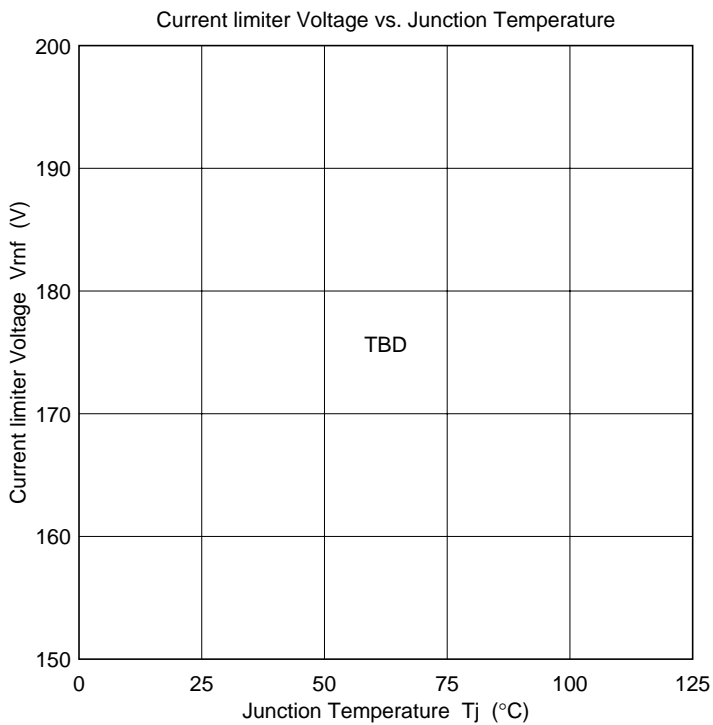
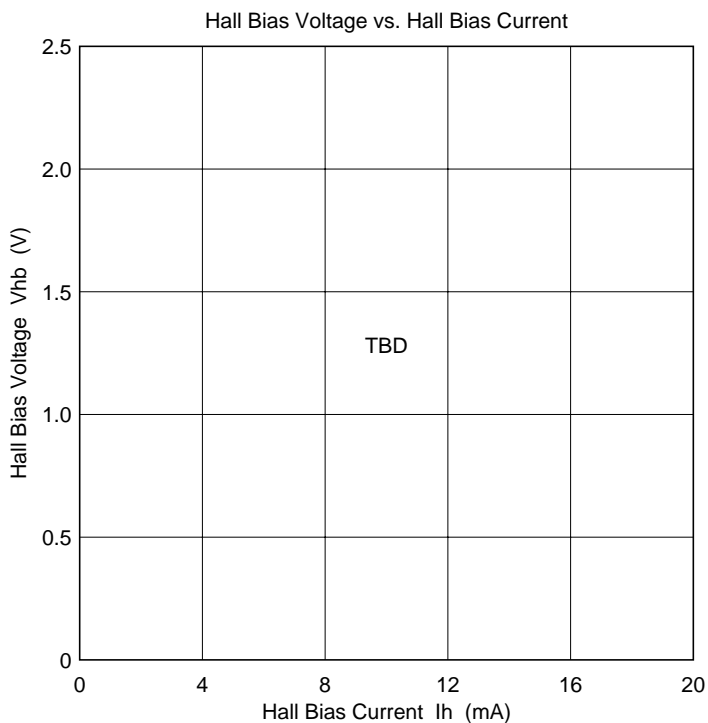

Package Dimensions

Unit: mm

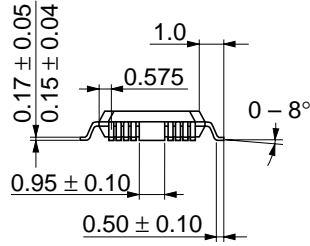
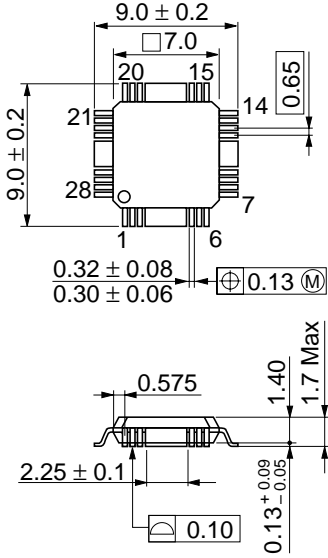

Hitachi Code	FP-28TB
JEDEC Code	—
EIAJ Code	—
Weight	0.19 g

Cautions

1. Hitachi neither warrants nor grants licenses of any rights of Hitachi's or any third party's patent, copyright, trademark, or other intellectual property rights for information contained in this document. Hitachi bears no responsibility for problems that may arise with third party's rights, including intellectual property rights, in connection with use of the information contained in this document.
2. Products and product specifications may be subject to change without notice. Confirm that you have received the latest product standards or specifications before final design, purchase or use.
3. Hitachi makes every attempt to ensure that its products are of high quality and reliability. However, contact Hitachi's sales office before using the product in an application that demands especially high quality and reliability or where its failure or malfunction may directly threaten human life or cause risk of bodily injury, such as aerospace, aeronautics, nuclear power, combustion control, transportation, traffic, safety equipment or medical equipment for life support.
4. Design your application so that the product is used within the ranges guaranteed by Hitachi particularly for maximum rating, operating supply voltage range, heat radiation characteristics, installation conditions and other characteristics. Hitachi bears no responsibility for failure or damage when used beyond the guaranteed ranges. Even within the guaranteed ranges, consider normally foreseeable failure rates or failure modes in semiconductor devices and employ systemic measures such as fail-safes, so that the equipment incorporating Hitachi product does not cause bodily injury, fire or other consequential damage due to operation of the Hitachi product.
5. This product is not designed to be radiation resistant.
6. No one is permitted to reproduce or duplicate, in any form, the whole or part of this document without written approval from Hitachi.
7. Contact Hitachi's sales office for any questions regarding this document or Hitachi semiconductor products.

HITACHI

Hitachi, Ltd.

Semiconductor & Integrated Circuits.
Nippon Bldg., 2-6-2, Ohte-machi, Chiyoda-ku, Tokyo 100-0004, Japan
Tel: Tokyo (03) 3270-2111 Fax: (03) 3270-5109

URL North America : <http://semiconductor.hitachi.com/>
 Europe : <http://www.hitachi-eu.com/hel/ecg>
 Asia (Singapore) : <http://www.has.hitachi.com.sg/grp3/sicd/index.htm>
 Asia (Taiwan) : http://www.hitachi.com.tw/E/Product/SICD_Frame.htm
 Asia (HongKong) : <http://www.hitachi.com.hk/eng/bo/grp3/index.htm>
 Japan : <http://www.hitachi.co.jp/Sicd/indx.htm>

For further information write to:

Hitachi Semiconductor
(America) Inc.
179 East Tasman Drive,
San Jose, CA 95134
Tel: <1> (408) 433-1990
Fax: <1>(408) 433-0223

Hitachi Europe GmbH
Electronic components Group
Dornacher Straße 3
D-85622 Feldkirchen, Munich
Germany
Tel: <49> (89) 9 9180-0
Fax: <49> (89) 9 29 30 00

Hitachi Europe Ltd.
Electronic Components Group.
Whitebrook Park
Lower Cookham Road
Maidenhead
Berkshire SL6 8YA, United Kingdom
Tel: <44> (1628) 585000
Fax: <44> (1628) 778322

Hitachi Asia Pte. Ltd.
16 Collyer Quay #20-00
Hitachi Tower
Singapore 049318
Tel: 535-2100
Fax: 535-1533

Hitachi Asia Ltd.
Taipei Branch Office
3F, Hung Kuo Building, No.167,
Tun-Hwa North Road, Taipei (105)
Tel: <886> (2) 2718-3666
Fax: <886> (2) 2718-8180

Hitachi Asia (Hong Kong) Ltd.
Group III (Electronic Components)
7/F., North Tower, World Finance Centre,
Harbour City, Canton Road, Tsim Sha Tsui,
Kowloon, Hong Kong
Tel: <852> (2) 735 9218
Fax: <852> (2) 730 0281
Telex: 40815 HITEC HX

Copyright ' Hitachi, Ltd., 1999. All rights reserved. Printed in Japan.

HITACHI