

TOSHIBA INSULATED GATE BIPOLAR TRANSISTOR SILICON N CHANNEL IGBT

# GT15J311, GT15J311(SM)

HIGH POWER SWITCHING APPLICATIONS

MOTOR CONTROL APPLICATIONS

Unit in mm

- The 3rd Generation
- Enhancement-Mode
- High Speed :  $t_f = 0.30 \mu s$  (Max.) ( $I_C = 15A$ )
- Low Saturation Voltage :  $V_{CE(sat)} = 2.7V$  (Max.) ( $I_C = 15A$ )
- FRD included between Emitter and Collector.

MAXIMUM RATINGS ( $T_a = 25^\circ C$ )

CHARACTERISTIC	SYMBOL	RATING	UNIT
Collector-Emitter Voltage	$V_{CES}$	600	V
Gate-Emitter Voltage	$V_{GES}$	$\pm 20$	V
Collector Current	DC	$I_C$	15 A
	1ms	$I_{CP}$	30 A
Emitter-Collector Forward Current	DC	$I_F$	15 A
	1ms	$I_{FM}$	30 A
Collector Power Dissipation ( $T_c = 25^\circ C$ )	$P_C$	70	W
Junction Temperature	$T_j$	150	$^\circ C$
Storage Temperature Range	$T_{stg}$	-55~150	$^\circ C$

EQUIVALENT CIRCUIT

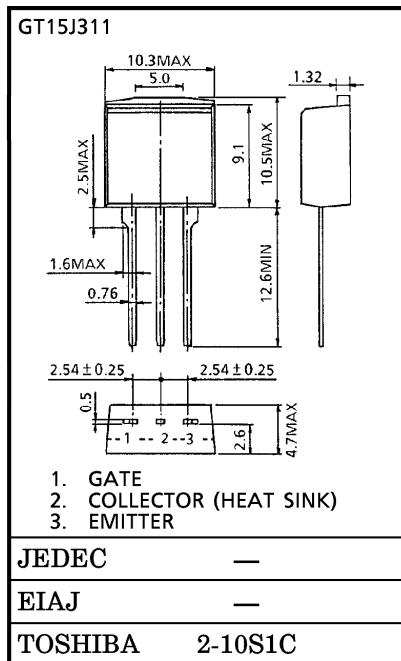
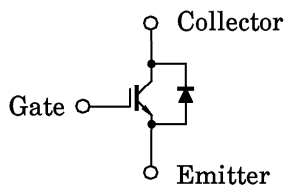

Weight : 1.5g

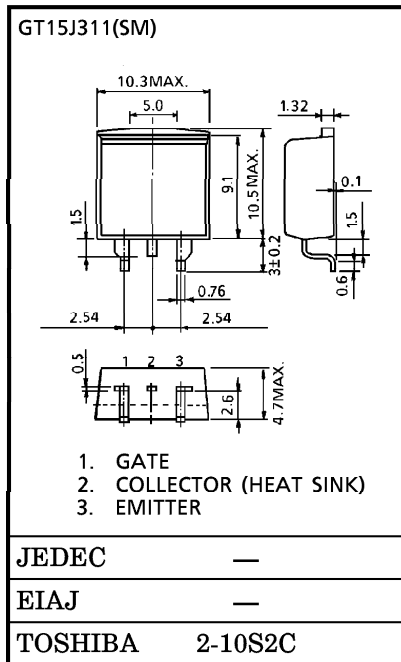

Weight : 1.4g

961001EAA2

- TOSHIBA is continually working to improve the quality and the reliability of its products. Nevertheless, semiconductor devices in general can malfunction or fail due to their inherent electrical sensitivity and vulnerability to physical stress. It is the responsibility of the buyer, when utilizing TOSHIBA products, to observe standards of safety, and to avoid situations in which a malfunction or failure of a TOSHIBA product could cause loss of human life, bodily injury or damage to property. In developing your designs, please ensure that TOSHIBA products are used within specified operating ranges as set forth in the most recent products specifications. Also, please keep in mind the precautions and conditions set forth in the TOSHIBA Semiconductor Reliability Handbook.
- The information contained herein is presented only as a guide for the applications of our products. No responsibility is assumed by TOSHIBA CORPORATION for any infringements of intellectual property or other rights of the third parties which may result from its use. No license is granted by implication or otherwise under any intellectual property or other rights of TOSHIBA CORPORATION or others.
- The information contained herein is subject to change without notice.

ELECTRICAL CHARACTERISTICS (Ta = 25°C)

CHARACTERISTIC	SYMBOL	TEST CONDITION	MIN.	TYP.	MAX.	UNIT
Gate Leakage Current	$I_{GES}$	$V_{GE} = \pm 20V, V_{CE} = 0$	—	—	$\pm 500$	nA
Collector Cut-Off Current	$I_{CES}$	$V_{CE} = 600V, V_{GE} = 0$	—	—	1.0	mA
Gate-Emitter Cut-Off Voltage	$V_{GE} (OFF)$	$I_C = 1.5mA, V_{CE} = 5V$	5.0	—	8.0	V
Collector-Emitter Saturation Voltage	$V_{CE} (sat)$	$I_C = 15A, V_{GE} = 15V$	—	2.1	2.7	V
Input Capacitance	$C_{ies}$	$V_{CE} = 20V, V_{GE} = 0, f = 1MHz$	—	950	—	pF
Switching Time	Rise Time	Inductive Load $V_{CC} = 300V, I_C = 15A$ $V_{GG} = \pm 15V, R_G = 75\Omega$ (Note 1)	—	0.12	—	$\mu s$
	Turn-On Time		—	0.40	—	
	Fall Time		—	0.15	0.30	
	Turn-Off Time		—	0.50	—	
Peak Forward Voltage	$V_F$	$I_F = 15A, V_{GE} = 0$	—	—	2.0	V
Reverse Recovery Time	$t_{rr}$	$I_F = 15A, di/dt = -100A/\mu s$	—	—	200	ns
Thermal Resistance (IGBT)	$R_{th(j-c)}$	—	—	—	1.79	°C/W
Thermal Resistance (Diode)	$R_{th(j-c)}$	—	—	—	3.45	°C/W

(Note 1) Switching time measurement circuit and input/output waveforms

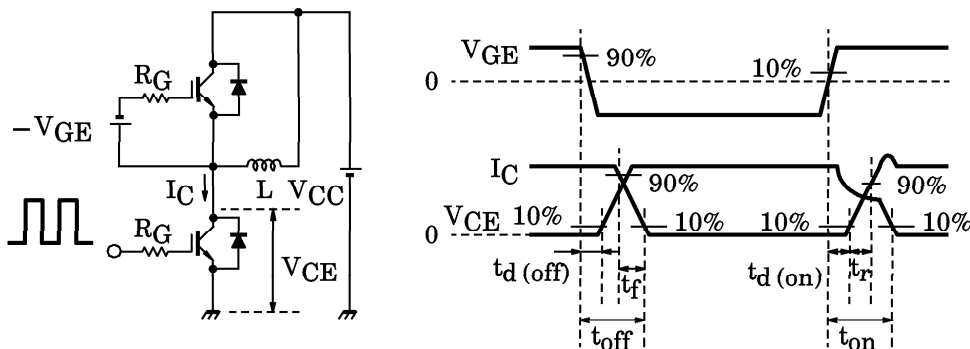

Switching loss measurement waveforms

