

GP1020

SIX-CHANNEL PARALLEL CORRELATOR CIRCUIT FOR GPS OR GLONASS RECEIVERS

The GP1020 is a six-channel CMOS digital correlator which has been designed to work with the GP1010 L1-channel down-converter or other integrated circuits, and may be used to acquire and track the GPS C/A code or the GLONASS signals.

For each of the six channels the GP1020 includes independent digital down-conversion to baseband, C/A code generation, correlation, and accumulate-and-dump registers.

The GP1020 interfaces with a microprocessor via a 16-bit data bus to control the acquisition and tracking processes using the various registers on the chip.

FEATURES

- Six Fully Independent Correlation Channels
- Switchable to Receive GPS or GLONASS Codes
- Input Multiplexer for Multiple GPS Front-Ends – Allows Antenna Diversity
- Input Multiplexer for GLONASS Multiple (Separate Channels) Front-Ends
- Digital Interface Compatible with Most 16 or 32-Bit Microprocessors
- Fully Compatible with GP1010 GPS Receiver Front-End
- Sideways Stackable to give Multiples of Six Channels
- 120-pin Plastic Quad Flatpack
- Power Dissipation Less Than 500mW

APPLICATIONS

- GPS or GLONASS Navigation Systems
- High Integrity Combined Receivers
- GPS Geodetic Receivers
- GPS Time Reference

ORDERING INFORMATION

The GP1020 is available in 120-pin Quad Flatpacks (Gullwing formed leads) in both Commercial (0°C to +70°C) and Industrial (-40°C to +85°C) grades. The ordering codes below are for standard screened devices.

ORDERING CODES

GP1020 CG GPKR Commercial - Plastic 120-pin QFP (GP120)
GP1020 IG GPKR Industrial - Plastic 120-pin QFP (GP120)

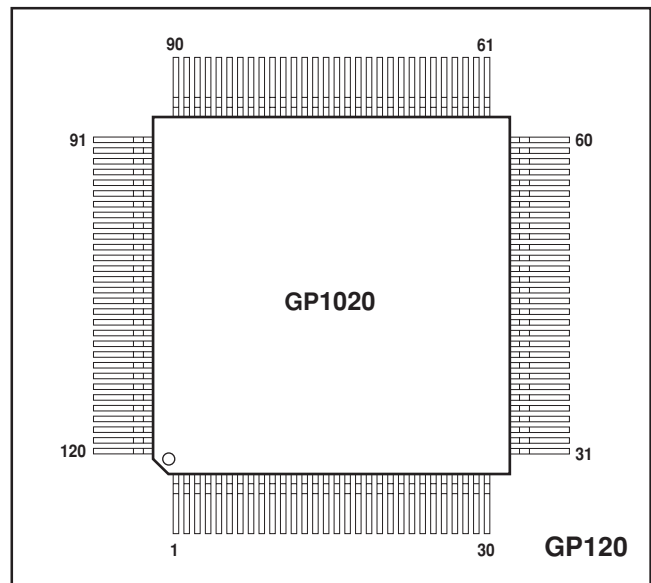

Fig 1 Pin connections - top view

ABSOLUTE MAXIMUM RATINGS

These are not the operating conditions, but are the absolute limits which if exceeded, even momentarily, may cause permanent damage. To ensure sustained correct operation the device should be used within the limits given under Electrical Characteristics.

Supply voltage (V_{DD}) from ground (V_{SS}): -0.3V to +6.0 V
 Input voltage (any input pin): $V_{SS}-0.3V$ to $V_{DD}+0.3 V$
 Output voltage (any output pin): $V_{SS}-0.3V$ to $V_{DD}+0.3 V$
 Storage temperature: -55°C to +125°C

RELATED PRODUCTS

Part	Description	Datasheet Reference
DW9255	35.42MHz SAW Filter	DS3861
GP1010	GPS Receiver Front-End	DS3076

GP1020

TYPICAL GPS RECEIVER (Fig. 2)

All satellites use the same L1 frequency of 1575.42MHz, but different Gold codes, so a single front-end may be used. To achieve better sky coverage it may be desirable to use more than one antenna, in which case separate front-ends will be needed.

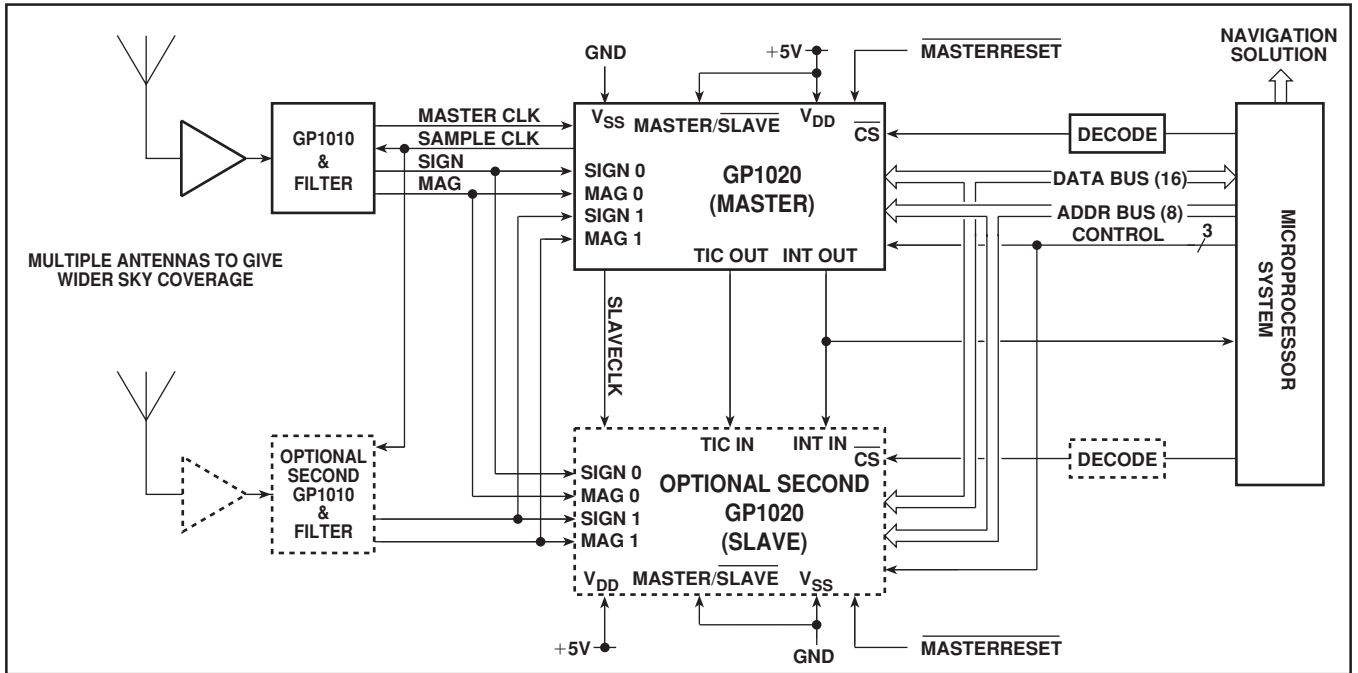

Fig. 2 GPS receiver simplified block diagram

TYPICAL GLONASS RECEIVER (Fig. 3)

Each satellite will use a different 'L1' carrier frequency, in the range 1602.5625 to 1615.500MHz, with 0.5625MHz spacing, but all with the same 511-bit spreading code. The normal method for receiving these signals is to use several front-ends, perhaps with the first LNA and mixer common, but certainly with different final local oscillators and mixers.

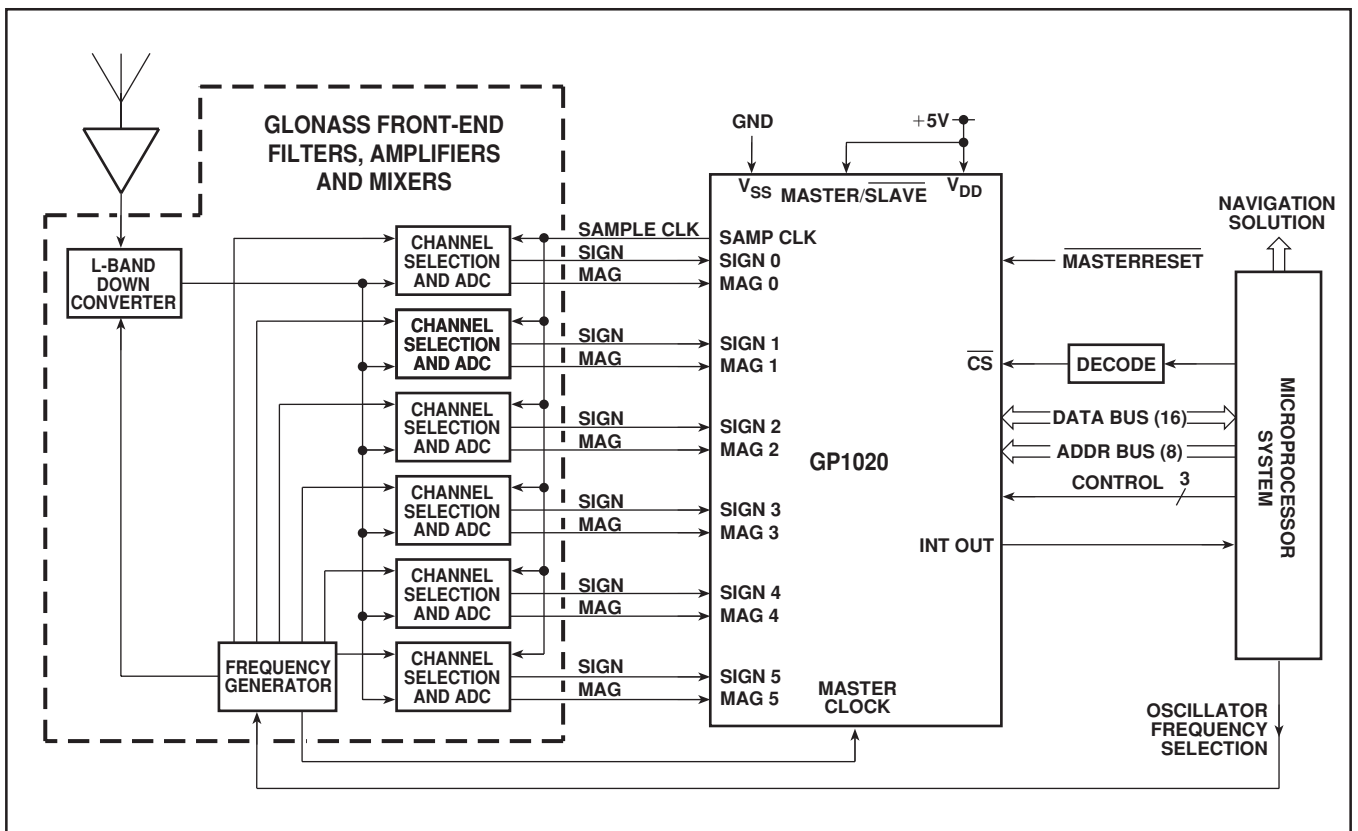

Fig. 3 GLONASS receiver simplified block diagram

PIN DESCRIPTIONS (See Application Notes, p. 41)

All V_{SS} and all V_{DD} pins must be used in order to ensure reliable operation. Several pins, such as Satellite Inputs 2 to 9 Sign and Magnitudes are also used for device testing, but only as a secondary function.

Pin No.	Signal name	Type	Description
1	A7	I	Register Address, bit 7
2	A8	I	Register Address, bit 8
3	MASTER/ SLAVE	I	Master or slave mode select
4	TSCAN	I	Scan Test mode select
5	TCKS	I	Test Clock select
6	TDI1	I	Serial Test Data Input
7	MASTER RESET	I	Master Reset (active low)
8	MOT/INTEL	I	Motorola (hi) or Intel (lo) bus select
9	CS	I	Chip Select (active low) for bus
10	V_{SS}	-	Ground
11	V_{DD}	+	Positive supply
12	WEN	I	Bus control - see note 1
13	RW	I	Bus control - see note 1
14	TMS2	I	Test Mode Select 2
15	TMS1	I	Test Mode Select 1
16	TMAG	O	Test PRN Pattern Magnitude o/p
17	TSIGN	O	Test PRN Pattern Sign output
18	MAG2	I/O	Satellite Input 2, Magnitude
19	100/219kHz	O	Programmable Interrupt Timer clock
20	V_{DD}	+	Positive supply
21	V_{SS}	-	Ground
22	INTOUT	O	Interrupt out to microprocessor
23	SIGN2	I/O	Satellite Input 2, Sign
24	MAG3	I/O	Satellite Input 3, Magnitude
25	SIGN3	I/O	Satellite Input 3, Sign
26	MAG4	I/O	Satellite Input 4, Magnitude
27	SIGN4	I/O	Satellite Input 4, Sign
28	MAG5	I/O	Satellite Input 5, Magnitude
29	SIGN5	I/O	Satellite Input 5, Sign
30	MAG6	I/O	Satellite Input 6, Magnitude
31	SIGN6	I/O	Satellite Input 6, Sign
32	MAG7	I/O	Satellite Input 7, Magnitude
33	SIGN7	I/O	Satellite Input 7, Sign
34	MAG8	I/O	Satellite Input 8, Magnitude
35	SIGN8	I/O	Satellite Input 8, Sign
36	MAG9	I/O	Satellite Input 9, Magnitude
37	SIGN9	I/O	Satellite Input 9, Sign
38	MAG1	I/O	Satellite Input 1, Magnitude
39	SIGN1	I/O	Satellite Input 1, Sign
40	V_{SS}	-	Ground
41	V_{DD}	+	Positive supply
42	MAG0	I	Satellite Input 0, Magnitude
43	SIGN0	I	Satellite Input 0, Sign
44	SAMPCLK	O	Sampling clock to down-converter
45	V_{DD}	+	Positive supply
46	MASTERCLK	I	40MHz Master Clock
47	V_{SS}	-	Ground
48	Bias	O	Bias for MASTERCLK in 600mV AC-coupled mode
49	V_{SS}	-	Ground
50	V_{DD}	+	Positive supply
51	V_{SS}	-	Ground
52	CLKSEL	I	Sets 100/219kHz to 100or 219kHz
53	PLLLOCKIN	I	PLL lock status from down-converter
54	BITECNTL	O	BITE control to down-converter
55	GLONASSBIT	I	I/P to monitor GLONASS front-end
56	SLAVECLK	I/O	20MHz clock from Master to slave
57	INTIN	I	Interrupt to slave to sync to Master
58	TCK1	I/O	Test Clock 1
59	TCK2	I/O	Test Clock 2
60	TCK3	I/O	Test Clock 3
61	TCK4	I/O	Test Clock 4
62	TCK5	I/O	Test Clock 5
63	TCK6	I/O	Test Clock 6
64	TCK7	I/O	Test Clock 7
65	TCK8	I	Test Clock 8

Pin No.	Signal name	Type	Description
66	TICIN	I	TIC input to slave
67	TICOUT	O	TIC output from Master
68	D0	I/O	Data Bus, bit 0
69	D1	I/O	Data Bus, bit 1
70	V_{SS}	-	Ground
71	V_{DD}	+	Positive supply
72	D2	I/O	Data Bus, bit 2
73	D3	I/O	Data Bus, bit 3
74	TIME MARK	O	One pulse per second output
75	RTCINT	I	Real time clock interrupt input
76	MARKFB1	I	Timemark line driver feedback
77	MARKFB2	I	Timemark line driver feedback
78	D4	I/O	Data Bus, bit 4
79	D5	I/O	Data Bus, bit 5
80	V_{DD}	+	Positive supply
81	V_{SS}	-	Ground
82	D6	I/O	Data Bus, bit 6
83	D7	I/O	Data Bus, bit 7
84	WPROG	I	Bus timing mode - see note 2
85	NANDA	I	Test Structure - see note 3
86	NANDB	I	Test Structure - see note 3
87	TDO	O	Boundary Scan output
88	TCK	I	Boundary Scan clock
89	TRST	I	Boundary Scan reset
90	NANDOP	O	Test Structure - see note 3
91	TMS	I	Boundary Scan control
92	TDI	I	Boundary Scan input
93	MARKFB3	I	Timemark line driver feedback
94	TDO7	O	Serial Test Data Output 7
95	DISCOP	O	On/Off control for LNA by GP1010
96	TDO6	O	Serial Test Data Output 6
97	TDO5	O	Serial Test Data Output 5
98	D8	I/O	Data Bus, bit 8
99	D9	I/O	Data Bus, bit 9
100	V_{SS}	-	Ground
101	V_{DD}	+	Positive supply
102	D10	I/O	Data Bus, bit 10
103	D11	I/O	Data Bus, bit 11
104	TDO4	O	Serial Test Data Output 4
105	TDO3	O	Serial Test Data Output 3
106	TDO2	O	Serial Test Data Output 2
107	TDO1	O	Serial Test Data Output 1
108	D12	I/O	Data Bus, bit 12
109	D13	I/O	Data Bus, bit 13
110	V_{DD}	+	Positive supply
111	V_{SS}	-	Ground
112	D14	I/O	Data Bus, bit 14
113	D15	I/O	Data Bus, bit 15
114	ALE	I	Address Latch Enable, bus control
115	A1	I	Register Address, bit 1 (LSB)
116	A2	I	Register Address, bit 2
117	A3	I	Register Address, bit 3
118	A4	I	Register Address, bit 4
119	A5	I	Register Address, bit 5
120	A6	I	Register Address, bit 6

NOTE 1. The functions of RW and WEN pins depend on whether the GP1020 is in Motorola™ (MOT/INTEL = '1') or Intel™ mode (MOT/INTEL = '0'). In Motorola mode, WEN is an enable (active high) and RW is Read/Write select ('1' = Read). In Intel mode RW is Read, active low, and WEN is Write, also active low.

MOT/INTEL	Mode	WEN	RW	Function
1	Motorola	1	0	Write
1	Motorola	1	1	Read
0	Intel	1	0	Read
0	Intel	0	1	Write

NOTE 2. WPROG is used to modify the timing of bus operations; when it is held HIGH the internal write signal is ORED with ALE to allow time for the internal address lines to stabilise; when it is held LOW there is no delay added to write. **NOTE 3.** NANDOP (pin 90) is the output of a spare gate with inputs on NANDA (pin 85) and NANDB (pin 86).

ELECTRICAL CHARACTERISTICS

These characteristics are guaranteed over the following conditions (unless otherwise stated):

Supply voltage, $V_{DD} = 5V \pm 10\%$; Ambient Temperature, $T_{AMB} = 0^{\circ}C$ to $+70^{\circ}C$ (CG grade), $-40^{\circ}C$ to $+85^{\circ}C$ (IG grade).

DC CHARACTERISTICS

Characteristic	Value			Units	Conditions
	Min.	Typ.	Max.		
Supply current, I_{DD} , chip fully active			100	mA	
CMOS inputs with pullup resistors to V_{DD} : <u>RTCINT</u>, <u>MASTER/SLAVE</u>, <u>MARKFB</u> (3:1), <u>NANDA</u>, <u>NANDB</u>, <u>WPROG</u>, <u>ALE</u>					
Input voltage high	$0.8V_{DD}$			V	
Input voltage low			$0.2V_{DD}$	V	
Pullup resistor	20	75	250	k Ω	
CMOS inputs with pulldown resistors to V_{SS} : <u>MOT/INTEL</u>, <u>CLKSEL</u>, <u>INT IN</u>, <u>TIC IN</u>					
Input voltage high	$0.8V_{DD}$			V	
Input voltage low			$0.2V_{DD}$	V	
Pulldown resistor	20	75	250	k Ω	
CMOS inputs without either pullup or pulldown resistors: <u>MASTERRESET</u>, <u>CS</u>, <u>WEN</u>, <u>RW</u>, <u>MASTERCLK</u> (note 1), <u>SLAVECLK</u>, <u>A</u> (8:1), <u>D</u> (15:0), <u>TCK</u>, <u>TDI</u>, <u>TMS</u>, <u>TRST</u>					
Input voltage high	$0.8V_{DD}$			V	
Input voltage low			$0.2V_{DD}$	V	
Input leakage current		1	10	μA	$V_{SS} < V_{PIN} < V_{DD}$
TTL inputs with pullup resistors to V_{DD} : <u>SIGN</u> (9:0), <u>MAG</u> (9:0), <u>PLLLOCKIN</u>, <u>GLONASSBIT</u>					
Input voltage high	2.0			V	
Input voltage low			0.8	V	
Pullup resistor	20	75	250	k Ω	
TTL inputs with pulldown resistors to V_{SS} : <u>TSCAN</u>, <u>TCKS</u>, <u>TDI1</u>, <u>TMS1</u>, <u>TMS2</u>					
Input voltage high	2.0			V	
Input voltage low			0.8	V	
Pulldown resistor	20	75	250	k Ω	
Input for low level clocks: <u>MASTERCLK</u> (note 1)					
Peak to peak sinewave	600			mV	AC coupled
Power level 1 outputs: <u>TMAG</u>, <u>TSIGN</u>, <u>TDO</u>, <u>TDO</u> (7:1), <u>NANDOP</u>					
Output voltage high	$V_{DD}-1$	$V_{DD}-0.5$		V	$I_{OH} = -1.5mA$
Output voltage low		0.2	0.4	V	$I_{OL} = 1.5mA$
Power level 3 outputs: <u>100/219kHz</u>, <u>INT OUT</u>, <u>SAMPCLK</u>, <u>TIC OUT</u>, <u>BITE CNTL</u>, <u>DISCOP</u>, <u>TIMEMARK</u>					
Output voltage high	$V_{DD}-1$	$V_{DD}-0.5$		V	$I_{OH} = -4.5mA$
Output voltage low		0.2	0.4	V	$I_{OL} = 4.5mA$
Power level 1 outputs with tri-state: <u>MAG</u> (9:2), <u>SIGN</u> (8:2), <u>TCK</u> (7:1)					
Output voltage high	$V_{DD}-1$	$V_{DD}-0.5$		V	$I_{OH} = -1.5mA$
Output voltage low		0.2	0.4	V	$I_{OL} = 1.5mA$
Output leakage current			10	μA	$V_{SS} < V_{PIN} < V_{DD}$
Power level 3 output with tri-state: <u>SLAVECLK</u>					
Output voltage high	$V_{DD}-1$	$V_{DD}-0.5$		V	$I_{OH} = -4.5mA$
Output voltage low		0.2	0.4	V	$I_{OL} = 4.5mA$
Output leakage current			10	μA	$V_{SS} < V_{PIN} < V_{DD}$
Power level 6 output with tri-state: <u>D</u> (15:0)					
Output voltage high	$V_{DD}-1$	$V_{DD}-0.5$		V	$I_{OH} = -9.0mA$
Output voltage low		0.2	0.4	V	$I_{OL} = 9.0mA$
Output leakage current			10	μA	$V_{SS} < V_{PIN} < V_{DD}$
Bias output: <u>BIAS</u>	Special output to be used only as shown in Fig. 12 (page 8)				

NOTE 1. The input MASTERCLK may be driven by either CMOS logic levels or by a low amplitude sinewave if the BIAS pin is connected as shown in Fig. 12.

TIMING CHARACTERISTICS (See Figs. 4 to 9)

Characteristic	Symbol	Value		Units	Conditions
		Min.	Max.		
Address hold time	t_{AHOLD}	10		ns	
ALE pulse width	t_{ALEPW}	20		ns	
ALE valid to WEN or RW valid (WPROG = 1)	$t_{ALESETUP}$	5		ns	
ALE valid to WEN or RW valid (WPROG = 0)	t_{ALVWRV}	20		ns	
Address valid to ALE low	t_{ASETUP}	20		ns	
Address valid to WEN or RW valid	t_{AVWRV}	20		ns	
CS high to ALE valid	t_{CHALV}	10		ns	
CS low to WEN or RW valid	t_{CVWRV}	0		ns	
Data hold time	t_{DHOLD}	10		ns	
Data setup time	t_{DSETUP}	30		ns	
RW high to data at high impedance	t_{RHDZ}	10	25	ns	
RW valid to data valid	t_{RVDV}	10	50	ns	
RW valid to WEN high	$t_{RWVWENH}$	15		ns	
WEN low to RW not valid	$t_{WENLRWNV}$	15		ns	
Write pulse width	t_{WLWH}	30		ns	
CS hold time after RW or WEN not valid	t_{WRCH}	0		ns	

NOTE. This timing information is based on simulations and is not verified by measurement on each device.

GP1020 BUS TIMING DIAGRAMS

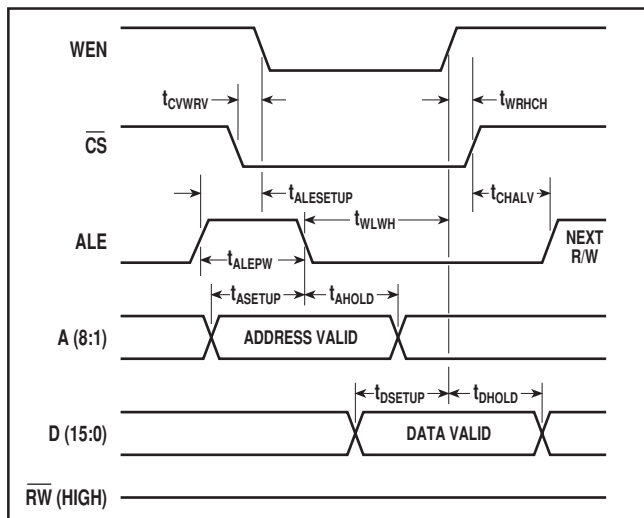

Fig. 4 Intel 486 mode WRITE. MOT/INTEL = 0, WPROG = 1 (Write inhibited until ALE falling edge)

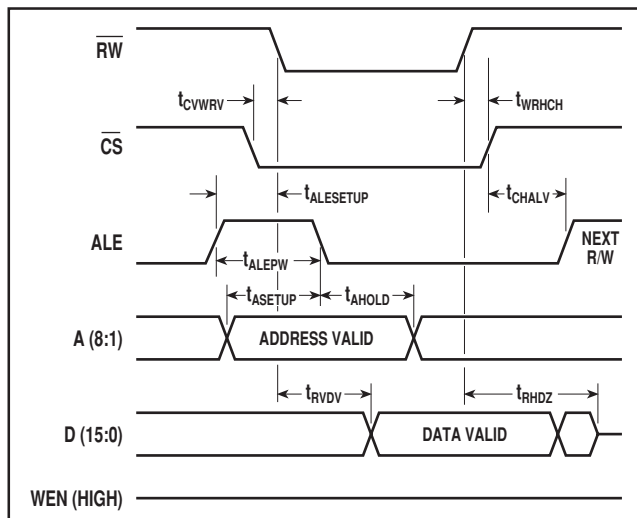

Fig. 5 Intel 486 mode READ. MOT/INTEL = 0, WPROG = 1

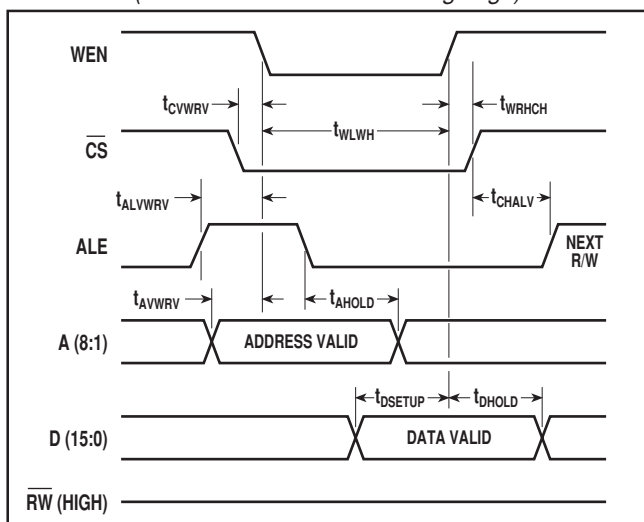

Fig. 6 Intel 186 mode WRITE. MOT/INTEL = 0, WPROG = 0

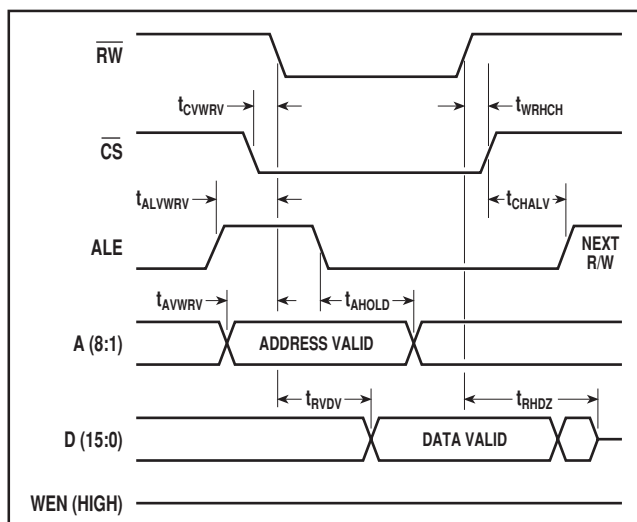

Fig. 7 Intel 186 mode READ. MOT/INTEL = 0, WPROG = 0

GP1020 BUS TIMING DIAGRAMS (continued)

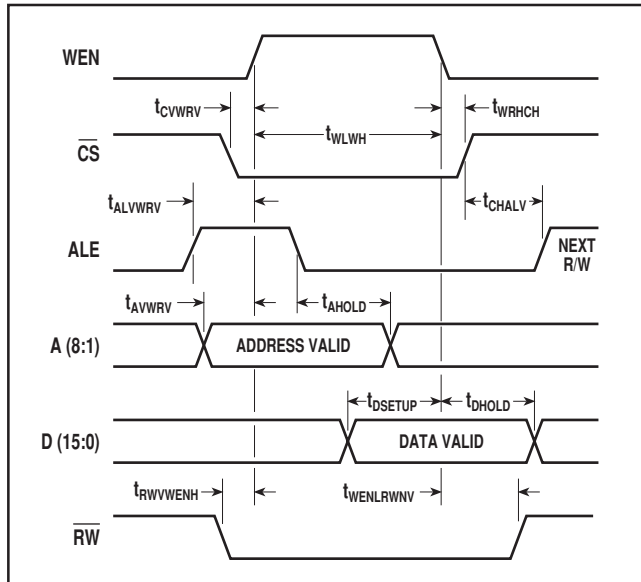

Fig. 8 Motorola 68xxx mode WRITE. MOT/INTEL = 1, WPROG = 0

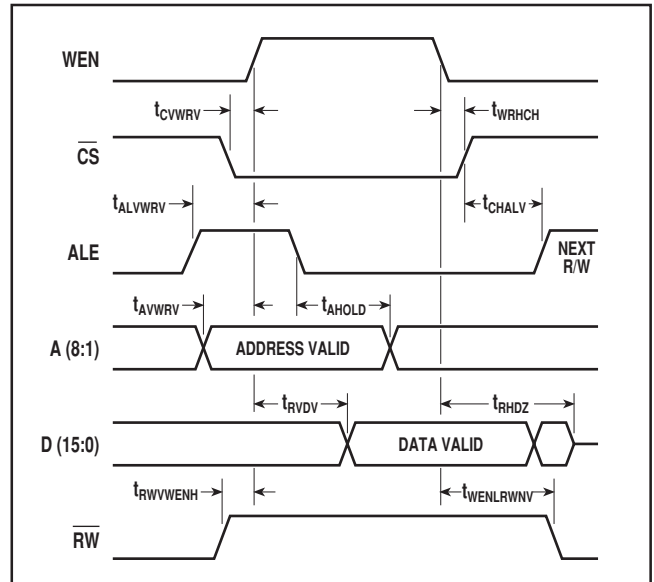

Fig. 9 Motorola 68xxx mode READ. MOT/INTEL = 1, WPROG = 0

SIGNAL PROCESSING OVERVIEW

Each channel of the GP1020 is fed with a 2-bit (or optionally with a 1-bit) GPS digital IF at around 1.4MHz, from the input multiplexer that connects one of ten signal sources to the channel input. This signal is first brought to baseband using an on-chip digital mixer driven by a programmable digital local oscillator. It is then correlated with a C/A code internally generated by a programmable Gold code generator; the correlation result is the sum of the comparisons of individual code chips over a complete code period (an 'epoch' in GPS terminology). A large positive or a large negative sum indicate good correlation but with opposite modulation, where the size of 'large' will depend on the current signal to noise ratio, while a small sum indicates poor correlation and the need to adjust the loops or choose another satellite.

These results form the 'Accumulated Data' and are made available to the microprocessor to both control the tracking loops and to give the broadcast satellite data, the 'Navigation Message' when demodulated. Periodically, the code epoch count, the code phase, and the carrier phase of all channels, are sampled at the same instant to form the 'Measurement Data' and are also made available to the processor.

DESCRIPTION OF BLOCKS (see Fig. 10)

CLOCK GENERATOR

The Clock Generator block generates the various clocks required in the GP1020, which can be operated either as a master or as a slave device. When it is operated as a master, the Clock Generator block is driven by a 40MHz clock provided by the accompanying front-end chip, the GP1010, and to drive the slaves a 20MHz output SLAVE CLK is provided. When the GP1020 is operated as a slave, it is driven only by this 20MHz SLAVE CLK from the master device. In the master the 40MHz is divided in a counter to form seven clock phases to control the data flow, but to get the same timing in the slaves twin 20MHz dividers use both high and low phases separately to give the effect of 40MHz clocking.

When in master mode these seven phases are also used to generate a sampling clock (SAMP CLK) output at $40\text{MHz} \div 7 = 5.71\text{MHz}$, which drives the data sampling clock input of the GP1010. A 100/219kHz output is provided for use as a microprocessor Programmable Interrupt Clock.

TIMEBASE GENERATOR

The Time Base Generator produces, among other signals: a 505.05 μs free-running interrupt timebase INT OUT, a free-running TIC OUT signal with a period which may be selected to be either 100ms or 9.09ms (approximately), and a TIME MARK signal with a 1 second period as an output which may be locked to GPS time, UTC, or the receiver timebase by programming its delay relative to the TIC, based on recent navigation solutions. The TIC is mainly used to latch measurement data (epoch count, code phase, code DCO phase and integrated carrier phase (= DCO phase and cycle count)) of all six channels at the same instant.

BITE INTERFACE

The Bite Interface block contains a register which allows control over the built-in-test functions of the chip. In addition, this register allows the processor to read the state of discrete input pins, such as PLLLOCKIN connected to the status output of the GP1010, and also to set the state of the BITE CNTL and the DISCOP output pins. These can in turn, for example, be used to drive the GP1010 BITE input pin and the LNA power on/off select, respectively.

STATUS REGISTERS

The Status Registers block contains registers describing the status of accumulated and measurement data provided by each channel.

SIGNAL SELECTION BLOCK

The Signal Selection block contains a multiplexer which can be programmed to direct any of the ten input sources to any of the six tracking channels. This is needed in GLONASS where frequency division multiplexing is used and separate local oscillators are needed to receive each satellite, leading to separate IF filter channels. An input selector may be desirable in GPS, which uses code division multiplexing, to allow the use of multiple antennae to overcome problems of incomplete sky visibility.

For SIGN inputs, LOW = -, HIGH = +; for MAG inputs, LOW = 1, HIGH = 3.

TRACKING MODULE BLOCKS

The six Tracking Module blocks are all identical so that the term CHx is used in the description to mean any of CH1, CH2,

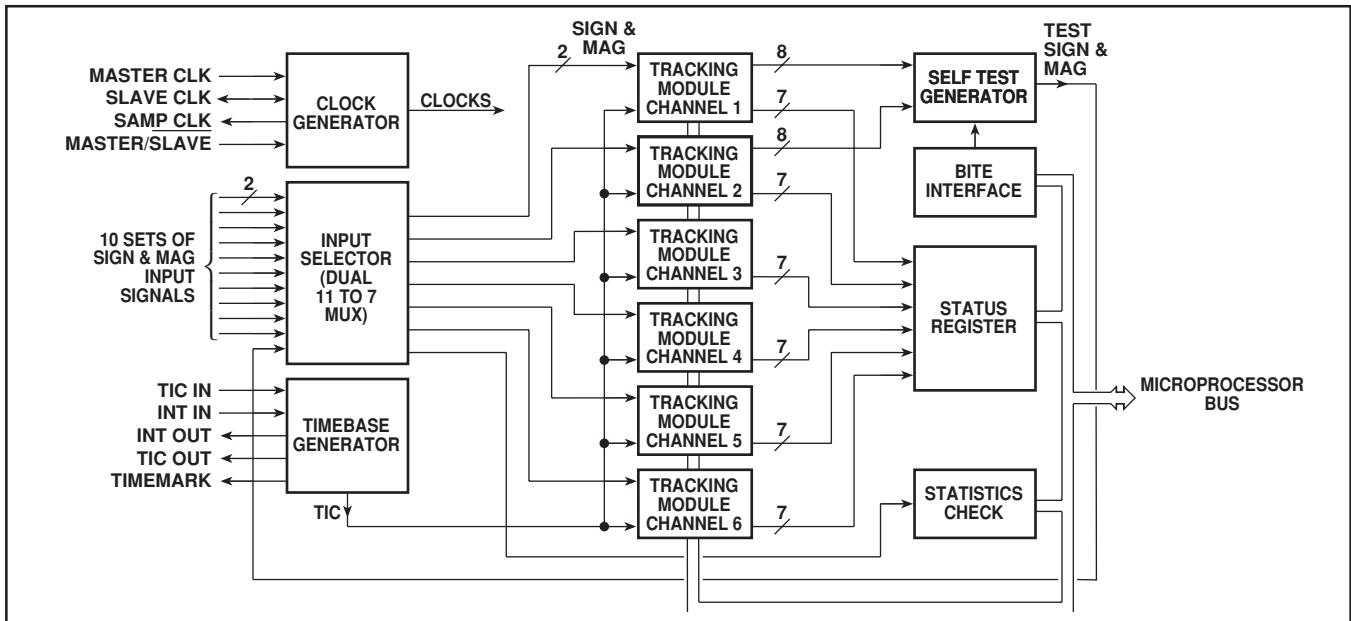

Fig. 10 Simplified overall block diagram

CH3, CH4, CH5 or CH6 inputs or registers. They have the architecture shown in Fig. 11. The individual sub-blocks are as follows:

CARRIER DCO

The Carrier DCO is an accumulator performing additions at a constant rate and with a programmable increment value. It is used to synthesise the digital local oscillator signal required to bring the input signal to baseband in the mixer block, and must be adjusted away from nominal to allow for Doppler shift and crystal frequency error. The nominal frequency of the output is 1.405396825 MHz, set by loading the 26 bit CHx_CARR_INCR register to 01F7B1B9_H and is programmed with a resolution of 42.57475 milliHertz. The very fine resolution is needed to keep the DCO in phase with the satellite signal.

CODE DCO

This block is a similar structure to the Carrier DCO block and is used to synthesise the oscillator signal required to drive the code generator at the proper chipping rate and phase. The nominal frequency of the output is 2.046MHz, to give a chip rate of 1.023MHz, and is set by loading the 25 bit CHx_CODE_INCR register to 016EA4A8_H and is programmed with a resolution of 85.14949 milliHertz. Again, the very fine resolution is needed to keep the DCO in phase with the satellite signal.

CODE GENERATOR

This generates the processor-selected GPS Gold code (one of PRN code numbers 1 to 32 for normal satellites or 33 to 37 for ground based use) or the GLONASS code (fixed for all satellites) or one of eight INMARSAT codes. Twin generators are used to produce both a prompt (on-time) pattern and an early, late, or early-minus-late version for tracking use. At the end of each code sequence a signal DUMP is generated to latch the Accumulated Data, separately for each channel.

MIXER AND CORRELATOR

The Mixer and Correlator first mixes the digitised input signal with the Carrier DCO digital local oscillator to generate a signal at baseband, and then uses the Code Generator outputs to correlate the data stream. The block includes in-phase and phase-quadrature channels, as well as prompt and dithered (or early/late) correlator arms.

The term dither is used in the GP1020 to mean a code channel in which the timing alternates one half-chip either before or after the prompt channel, and not the now obsolete technique of Taudither, in which the prompt arm timing is oscillated a little each side of nominal to give tracking with only one arm.

QUADRUPLE INTEGRATE AND DUMP

The bit-by-bit results from the correlator are passed to the Quadruple Integrate And Dump block, which integrates the correlation result of individual code chips from all four correlators (in-phase and phase-quadrature, prompt and dithered arms) over a complete code period. Through the Accumulated Data registers, the processor has access to each integration result.

NAVIGATION OR TIME REFERENCE RECEIVER HARDWARE SYSTEM DESIGN

A receiver system can use one or more GP1020s. When only one is used, that IC is operated in master mode, and when more than one are used, one of them is designated as being the *master* and all of the others are operated as *slaves*. In all cases, the master chip is the one which will receive the 40MHz MASTER CLK from the GP1010 and generate, upon release of the MASTERRESET signal, a gated 20MHz clock which drives all slaves (if any) and allows a synchronised start-up. The master device also generates the SAMP CLK signal which drives all of the GP1010 front-ends.

The operating mode is programmed by tying the MASTER/SLAVE pin to V_{DD} for master or to V_{SS} for slave operation. The operating mode sets the functions of MASTER CLK, SLAVE CLK and SAMP CLK pins.

The TIME MARK signal is generated by the master GP1020; the slave TIME MARK generator, although not disabled, is not synchronised with the master. The TIC signal is generated by the master and routed to the slaves to ensure a common measurement data sampling instant for all the tracking channels. The slave TIC OUT signal is not disabled but is not used.

The master INT OUT drives the slaves' INT IN pins to provide latching of status bits at a common instant. Optionally, the slave TIC OUT and INT OUT pins could be connected to the master TIC IN and INT IN pins, respectively, for testing purposes.

When more than one GP1020 is used in the same system, the devices must share a common TIC for sampling of measurement data to enable the software to calculate clock bias in the pseudoranges, and so find the correct ranges. Each GP1020 contains a state machine driven by 7 different clock phases, so for two GP1020s to share a common TIC, the devices must be synchronised. This is achieved by configuring the hardware as follows:

- All GP1020s share the same MASTERRESET signal.
- One GP1020 is designated the master chip. It is

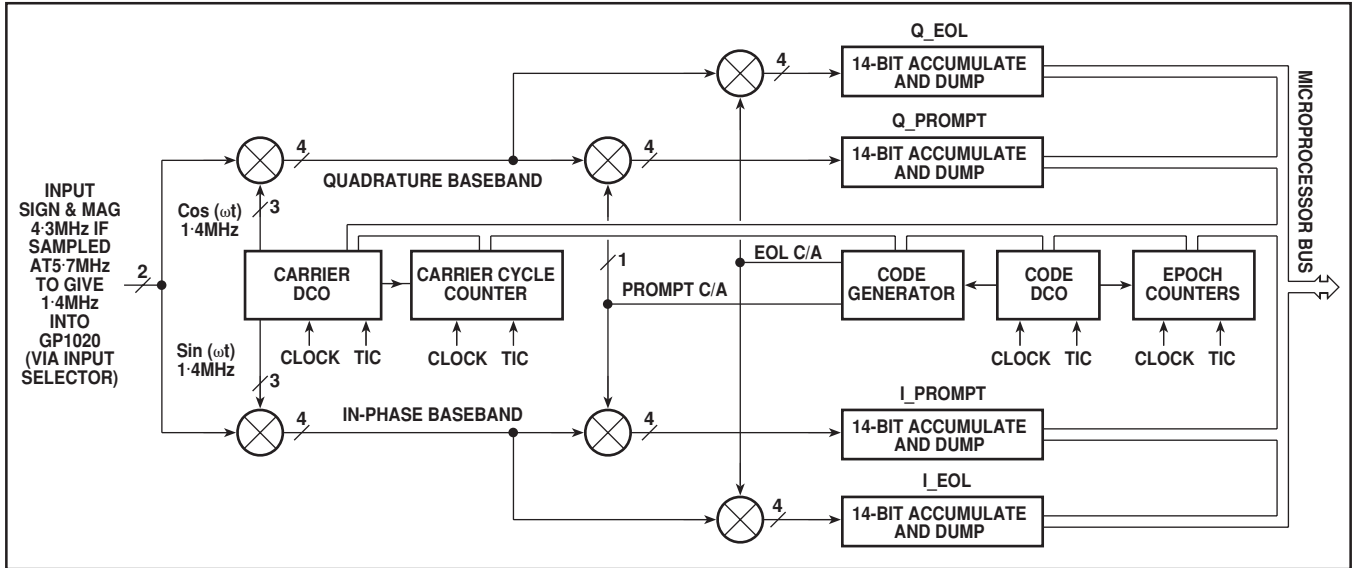

Fig. 11 Tracking module simplified block diagram

programmed into this mode by tying the MASTER/SLAVE pin to V_{DD} (or by leaving it unconnected and relying on an internal pull-up resistor.)

- All other GP1020s are designated slaves and are programmed into this mode by tying their MASTER/SLAVE pin to V_{SS}.
- The master GP1020's SAMP CLK output drives all of the GP1010 front-ends. This ensures that in a multiple GP1010 application, all of the signals are being sampled at the same instant in all GP1010s. The slave GP1020s have their SAMPLING CLK output left unconnected.
- The SLAVE CLK output from the master drives the SLAVE CLK inputs on all slaves.

When the MASTERRESET is released, the clock generators of all devices – master and slaves – are enabled. The SLAVE CLK output of the master device will start to toggle only after the master's clock generator has reached a certain phase (200ns after the MASTERRESET release). The clock generator of the slave device gets reset into a state which corresponds to the next phase and starts counting as soon as the SLAVE CLK signal from the master reaches its SLAVE CLK input pin.

IMPORTANT TIMING SIGNALS IN A TYPICAL HARDWARE DESIGN

MASTER CLK

The MASTER CLK is a 40MHz clock which sets the timing of all functions in a GPS receiver using the GP1020. In a multiple GP1020 system only the master is given this clock and this may be connected in either of two ways, depending on the signal level. If the clock is a TTL signal it is directly connected to the MASTER CLK input and the BIAS output pin is left unconnected. The other option is an AC-coupled 600 mV peak-to-peak signal, when the BIAS output is used to set the DC voltage of the MASTER CLK pin as shown in Fig. 12. The MASTER CLK pin on each slave GP1020 is not used and should be tied to V_{DD} or V_{SS}.

SLAVE CLK

20MHz with 1:1 nominal mark:space ratio. Output from master GP1020, input to slave, using a bidirectional buffer controlled by MASTER/SLAVE. This signal is held low when the master chip is reset and starts to toggle within 200ns after MASTERRESET is released.

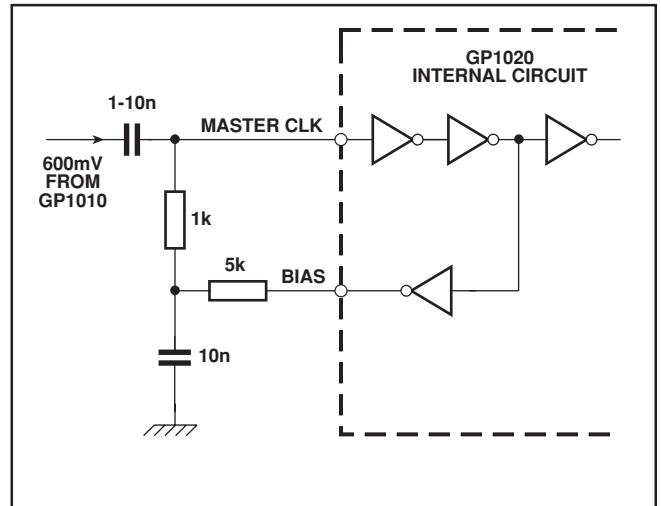

Fig. 12 Biasing circuit for master clock

SAMP CLK

40MHz ÷ 7 = 5.7142857MHz output when the chip is in master mode; nominal mark:space ratio is 1:1. This signal is held low during an active MASTERRESET and when in slave mode.

TICOUT

Output signal from TIC generator, used to sample measurement data and so initiate a navigation solution. TIC does not drive the microprocessor directly but sets a flag in MEAS_STATUS_A, which should be examined by reading the register periodically, such as at every INT OUT.

TICOUT is active high; active time duration is either 4.54545ms for a short TIC or 9.0909ms for a long TIC. The rising edge of TIC OUT is in advance of the effective sampling instant inside the device by 125ns. The TIC period is selectable via the TIC_PERIOD bit of TIMER_CNTRL register to either 100ms minus 100ns (= 99.9999ms) or to 9.0909 ms.

TIC IN

The TIC IN input of a GP1020 is normally provided by a companion GP1020. Its use is controlled by the TIC_SOURCE bit of the TIMER_CNTRL register and is configured in most applications so the master TIC OUT drives the slave TIC IN.

INT OUT

This output signal is a free running interrupt timebase which may be used to interrupt the microprocessor to initiate data transfer sufficiently often that no correlation results will be missed. The tracking loops rely on the microprocessor to adjust the DCO registers in response to signal changes so the rate of interaction must be sufficiently high. If the frequency of INT OUT is too high for the software to process then a polling scheme may be used, by inhibiting the interrupts (INT_MASK bit in TIMER_CNTL set low) and then periodically writing to STATUS_LATCH and reading the status registers to check if new data is available.

The period of INT OUT is programmable; a typical value is 505-05 μ s. During MASTERRESET the interrupt output is stopped and the pin is held LOW if in Intel mode, or HIGH if in Motorola mode. The active duration of INT OUT (HIGH for Intel, LOW for Motorola) is 252-525 μ s, which should be more than adequate to ensure that the interrupt controller in the processor will have time to respond.

INT IN

This input signal is normally provided by the INT OUT output of a companion GP1020; in general the master drives the slave. It is used, when selected via the INT_SOURCE bit of the TIMER_CNTL register, to latch the state of the status bits.

100kHz/219kHz

A clock output at either 100kHz or 219kHz which may be used to drive the microprocessor interrupt timer. The frequency is set by the level on CLKSEL (HIGH for 100kHz and LOW for 219kHz).

MASTERRESET

When MASTERRESET is set LOW, all the registers, accumulators and counters are cleared, except CHX_CNTL, which is initialised to specific values (refer to detailed description of the registers for these values). When the device is held reset, by MASTERRESET set low, the following pins are driven as listed:

- MASTER CLK:** This input may or may not be being externally driven during the reset. MASTERRESET internally gates MASTER CLK to ensure a well defined level on all clock lines until the release of MASTERRESET; the release of MASTERRESET must occur only when the input buffer is properly biased and the input signal is stable.
- SLAVE CLK:** Configured as an input on slave devices and held LOW on master device.
- SAMP CLK:** Held LOW.
- 100/219kHz:** This output is held LOW when MASTERRESET is active (also LOW) and toggles to HIGH shortly after MASTERRESET is released, and then runs normally.
- D0-D15:** High impedance.
- BITE CNTL:** LOW.
- DISC OP:** LOW.
- TIC OUT:** LOW.
- INT OUT:** This output is held LOW until interrupt inhibit is removed, when in Intel bus type mode, or is held HIGH until the inhibit is removed, when in Motorola bus type mode.

TIME MARK

The primary purpose of the TIME MARK output is to give a one pulse per second signal locked to UTC or GPS time. This may be followed by the correct time from the microprocessor and could be used as a reference by other navigation instruments

(e.g. ARINC 743 may be wanted) or a simple reference time clock may be built.

To synchronise TIME MARK to GPS time the first stage is to acquire the measurement data at any arbitrary TIC and then calculate the full navigation solution to give the time at that TIC. From this determine a later TIC at which to acquire data again such that after the navigation solution computation delay (typically a few TIC periods long) a further delay may be programmed into DOWN_COUNT_HI and _LO registers to start on the next TIC, to give TIME MARK at the required GPS whole second. This is rather a long process to get started, but once the first correct TIC choice and down counter delay are known the process can roll on with each TIC and delay calculation coming from the previous navigation solution.

To get UTC instead of GPS time it is only necessary to read the navigation message to get the number of whole seconds difference and add this to the calculated GPS time. A possible refinement is to calculate the oscillator drift over several measurements and use this to extrapolate a better value for the delay counter. The ultimate accuracy that can be achieved is very good, but to get this the crystal must both have high stability and be drift compensated in the software; in addition, the receiver front-end delay must be known and allowed for, and the delay through the output drivers and cables must be allowed for by using the MARKFBx pins.

If, as is likely, Selective Availability is on it will be the main source of error in a well designed TIME MARK system, but better than one microsecond absolute accuracy is still possible. To reduce the effects of SA it is possible to use a stable rubidium reference oscillator and average the induced offsets over a long time to give very good peak errors of a few tens of nanoseconds.

As the main purpose of the TIME MARK output is a timing reference signal at one pulse per second for the electronic systems in an airliner, it must be both accurate and known to be accurate.

The accuracy is achieved by loading DOWN_COUNT_HI and _LO with the correct offset in 50ns units from the GPS measuring TIC. As the TIC rate is nominally 1ppm less than 10Hz, the DOWN_COUNT value should be expected to increase at around 1 μ s per one second TIME MARK, a number change of +20 each pulse. This value will need continuous fine tuning to allow for the stable and variable crystal errors.

Integrity is ensured in two ways; first, by using PROP_DELAY to check the delay through line drivers and to verify that a TIME MARK really did occur and, secondly, by having a complex handshake sequence so that any failure in the hardware will be detected by the microprocessor. The handshake sequence is:

1. Write to DOWN_COUNT_LO to arm the TIME MARK generator (this requires that DOWN_COUNT_HI is already written; as it rarely changes, this is often automatically true).
2. At next TIC the GP1020 will start DOWN_COUNT.
3. The GP1020 will give a TIME MARK pulse output and start the PROP_DELAY counter.
4. Feed TIME MARK back through MARK_FBx input to stop PROP_DELAY and to set MARK_FB_ACK in MEAS_STATUS_A.
5. Read MEAS_STATUS_A, normally as part of the Measurement Data transfer protocol but, on this occasion, to also clear the overwrite protection on PROP_DELAY and to clear the MARK_FB_ACK bit.
6. Read PROP_DELAY, once MARK_FB_ACK has been set (and cleared) to give a stable value for the last delay. This also re-enables the TIME MARK generator ready for a repeat of step (1) to take effect.

This may seem rather complicated, but is only needed once per second and so is little overhead if a simple system is all that is required. For a full accuracy system, the various register operations fit in with the computations needed to achieve full ARINC 743 specification.

SATELLITE CODE SELECTION

This section describes the code selection for normal GPS and GLONASS operation; for INMARSAT codes and unusual techniques see full details in DETAILED DESCRIPTION OF REGISTERS section, under CHx_CNTL. The same section gives details of the other bits of CHx_CNTL.

The satellite code to be used by each channel is set by the CHx_CNTL registers, which are addressed individually from the A8-A1 address bus by:

00_H : Read/Write to Channel 1
 10_H : Read/Write to Channel 2
 20_H : Read/Write to Channel 3
 30_H : Read/Write to Channel 4
 40_H : Read/Write to Channel 5
 50_H : Read/Write to Channel 6
 70_H : Write only, to all channels simultaneously

The one GLONASS code may be selected by setting bit 10 HIGH, otherwise this bit should be set LOW and bits 7 to 0 used to select one of the GPS Gold codes (see Table opposite).

SOFTWARE REQUIREMENTS

The very wide variety of types of GPS or GLONASS receiver need to operate the correlator in different ways so, to accommodate this and also to allow dynamic adjustment of loop parameters, the GP1020 has been designed to use software for as many functions as possible. This flexibility means that the device cannot be used without a microprocessor closely linked to it, but as a processor is always needed to convert the output of the GP1020 into useful information this is not a significant limitation.

The software associated with the GP1020 can be divided into two separate modules: one to acquire and track satellite signals to give pseudoranges and another to process these to give the navigation solution and format it in a form suitable for the user. For the Navigation Solution to be possible all of the pseudoranges must have exactly the same clock error, which can then be removed iteratively to give real ranges if sufficient satellites are tracked (3 if the height is known, otherwise 4). This need for exact matching of timing errors explains the need for all of the complicated synchronisation between all channels and between master and slaves.

The following relates only to the signal processing aspects of the software, to acquire and track signals from up to six satellites per GP1020 and to obtain the pseudoranges and the navigation message. The operation of the navigation software is not dependent on the details of the correlator, and so does not need to be included in this data sheet.

An on-chip interrupt time base INT OUT is provided to help implement a data transfer protocol between the microprocessor and the GP1020 at fixed time intervals, otherwise a software based polling scheme will be needed – the choice is set by the application. If INT OUT is used, and perhaps also if polling is used, the data transfer rate is about twice the correlation result rate for each channel, so many transfers will not give new data. Bus use can be reduced by examining the status registers before each transfer to see if new data is available and then only reading the data if it useful.

It is important to note that the timing of each of the correlator channels will be locked to its own incoming signal and not to each other or to the microprocessor interrupts, so new data is generated asynchronously. The sampling instant of measurement data of all channels, however, is common to give a consistent navigation solution.

In order to acquire lock to the satellites as quickly as possible, the data from the last fix should be stored as a starting point for the next fix. It is also useful to have a real-time clock built into the receiver to give a good estimate of GPS time for the next fix; the navigation solution can be used to measure clock drift and calculate a correction for the clock to overcome ageing. The

Bit setting	GPS PRN reference number	Selected taps to be EXORed together
7654 3210		
0001 0101	1	2 6
0010 0110	2	3 7
0011 0111	3	4 8
0100 1xx0	4	5 9
0000 1xx0	5	1 9
0001 1xx1	6	2 10
0000 0111	7	1 8
0001 1xx0	8	2 9
0010 1xx1	9	3 10
0001 0010	10	2 3
0010 0011	11	3 4
0100 0101	12	5 6
0101 0110	13	6 7
0110 0111	14	7 8
0111 1xx0	15	8 9
1xx0 1xx1	16	9 10
0000 0011	17	1 4
0001 0100	18	2 5
0010 0101	19	3 6
0011 0110	20	4 7
0100 0111	21	5 8
0101 1xx0	22	6 9
0000 0010	23	1 3
0011 0101	24	4 6
0100 0110	25	5 7
0101 0111	26	6 8
0110 1xx0	27	7 9
0111 1xx1	28	8 10
0000 0101	29	1 6
0001 0110	30	2 7
0010 0111	31	3 8
0011 1xx0	32	4 9
0100 1xx1	33*	5 10
0011 1xx1	34* = 37	4 10
0000 0110	35*	1 7
0001 0111	36*	2 8
0011 1xx1	37* = 34	4 10

GPS Gold codes. *Note that these codes, 33 to 37, are reserved for non-satellite use only.

user's location (or a good estimate of it) along with the Almanac and the correct time will indicate which satellites should be searched for and may be used to find an estimate of Doppler effects, while the previous clock error is the best available estimate of the present clock error. If this information is not available then the receiver must scan a much wider range of values, which will greatly increase the time to lock. The satellite Clock Correction and Ephemeris are needed for the navigation solution, so if a recent set is held in memory the calculations may begin as soon as lock is achieved and not need to wait for the re-transmission (18 to 36 seconds).

This description applies to just one tracking channel but is the same this is not necessarily the same as the other channels. The GP1020 contains four different types of registers:

- **Control Registers** which are used to program functions of the device.
- **Status Registers** which provide a status indication of the process taking place in the device.
- **Accumulated Data Registers** which provide the results of correlation with the C/A code every millisecond. This is the raw data used to acquire and track satellite signals.
- **Measurement Data Registers** which latch the carrier DCO phase, carrier cycle count, code DCO phase, 1 millisecond

epoch, and the 20 millisecond epoch count at every 9.09 or 100 milliseconds interval. This is the raw data used to compute pseudorange.

SOFTWARE SEQUENCE FOR ACQUISITION

Satellite signals seen by a GPS receiver are so weak that they are buried in the noise and can only be detected by correlation. The spectrum of each signal is spread, using 1023 chip Gold codes for GPS or a 511 chip maximal length code for GLONASS; to correlate them therefore, a locally generated code must be chosen to precisely match the spreading code type, rate, and phase. This pattern is then multiplied bit-by-bit with the incoming data stream and the results integrated over the code length to recover the signal.

The process of signal acquisition is simply the matching of receiver settings to the actual signal values. To make matters more complicated the satellite carrier frequency is shifted a little by the Doppler effect due to the motion of the satellite, the user clock will drift randomly, and (in most situations) the signal to noise ratio is poor for some satellites. As a result, the software must be 'wide-band' to find the signal and also 'narrow-band' to reduce noise, leading to very different programs in different applications. For all tracking channels, the signal processing software needs the following sequence of activities:

1. Program CHx_CNTL register to select the desired GPS Gold code (PRN number) for the selected satellite and code type for the mode of the correlator dithering arm – it is often best, when in acquisition mode, to fix the dithering arm at early or at late and do a search in two phases at once and then switch to a tracking mode once a satellite is found.

2. Program CHx_CARR_INCR_LO and CHx_CARR_INCR_HI The values programmed into these two registers are concatenated and set the local oscillator frequency for the digital mixing performed in the GP1020 to bring the incoming 2-bit digitised signal down to baseband. The value to be programmed is equal to the nominal local oscillator frequency plus the estimated Doppler shift compensation plus the estimated user clock frequency drift compensation.

3. Program CHx_CODE_INCR_LO and CHx_CODE_INCR_HI The value to be programmed in these registers represents twice the nominal chipping rate of the C/A code (2.046 MHz) plus, if desired, a small compensation for the Doppler shift and for the user clock frequency drift.

4. Release the tracking channel reset by programming the RESET_CNTL Register with the proper value. This will cause the correlation process to start.

5. Obtain accumulated data from Accumulated Data Register readings. Several consecutive readings on the same tracking channel can be added to increase, at will, the integration period of the correlation.

6. Decide if the GPS signal has been found by comparing the correlation result with a threshold. If found then jump to a signal pull-in algorithm. Note that both in-phase and phase quadrature accumulated data have to be considered since at this time, the carrier DCO local oscillator phase is not necessarily in phase with the incoming GPS signal.

7. If the GPS signal has not been found, a new trial has to be made with different carrier DCO, code DCO, or Gold code phase programmings. Typically, both DCOs would be held constant while the Gold code phase is varied to try all of the 2046 half chip positions possible, then the carrier DCO would be programmed with slightly different values and the Gold code phase positions would again be scanned. The Gold code phase is varied by programming the CHx_CODE_SLEW Register and can be varied by increments of half a code chip.

8. Once the GPS signal has been found, the code phase alignment, the carrier phase alignment and the Doppler and user clock bias compensations are still coarse. The code phase alignment is only within a half code chip, the carrier DCO is not in phase with the incoming signal and its frequency is still in error by up to the increment used for successive trials.

The signal processing software must next use a pull-in algorithm to refine these alignments. There are many suitable types of algorithm to choose from, such as successive small steps until the error is too small to matter, like an analog PLL, or by using more complicated signal processing to estimate the errors and jump to a much better set of values. The signal pull-in algorithm will then program CHx_CARR_INCR_LO/HI registers with more accurate values for the Carrier DCO. Corrections to the Gold code phase smaller than a half chip cannot be done by programming CHx_CODE_SLEW registers in the Code Generator, but should set CHx_CODE_INCR_LO/HI registers to steer the Code DCO and gradually bring the Gold code phase to the right value.

SIGNAL TRACKING

The incoming GPS signal will exhibit a Doppler shift which varies with time due to the non-uniform motion of the satellite relative to the receiver, and the user clock bias is likely to also vary with time. The net result is that unless dynamic corrections are applied to the code and carrier DCOs, the GPS signal will be lost. This leads to two servo loops being required: one to maintain lock on the Gold code phase and a second to maintain lock on the carrier. With the GP1020 these servo loops are implemented in the signal processing software.

The raw data used to steer the two servo loops is the Accumulated Data, which is output by the tracking channel at the rate of once per millisecond. The dithering arm Accumulated Data is used for the Gold code loop; some approaches use an 'early minus late' Gold code to implement a null steering loop, others use a dithering code which alternates between a code one half chip late and a code one half chip early. In the GP1020, the dithering rate is 20 ms (20 code epochs) each way, starting with Early after a reset, when this type of code is selected through the CHx_CNTL register. The Gold code loop is closed by regularly updating the code DCO frequency using the CHx_CODE_INCR_LO/HI registers.

The prompt arm Accumulated Data is used for the carrier phase loop (although the dithering arm may also be used). One approach consists of varying the carrier DCO phase in order to maintain all the correlation energy in the in-phase correlator arm and none in the phase quadrature correlator arm. The carrier phase loop is closed by regularly updating the carrier DCO frequency using the CHx_CARR_INCR_LO/HI registers.

DATA DEMODULATION

The C/A code is modulated with Space Vehicle (SV) data at 50 Baud to give the navigation message. This modulation is an exclusive-OR function of the C/A code with the SV data. This means that every 20 milliseconds (which is every 20 C/A code epochs), the C/A code phase will be reversed (shifted by 180 degrees) if the new data bit is different from the previous one. On the prompt arm, once the signal is being correctly tracked, such a data bit transition will change the sign of the accumulated data. Data demodulation can then be achieved in two stages:

1. Locate the instants of data bit transitions to identify which C/A code epoch corresponds to the beginning of a new data bit. This will allow initialisation of the GP1020 epoch counters by the signal processing software (through the CHx_1MS_ and 20MS-EPOCH registers) to count code epochs from 0 to 19 in phase with data bits. At each new cycle of the 1 ms epoch counter, the 20 ms epoch counter will increment.

GP1020

2. Record the sign of accumulated data on the prompt arm for each data bit period of 20 ms, with filtering to reduce the effect of noise on the signal. Note that there is a sign ambiguity in the demodulation process in that it is not possible to tell which data bits are '0's and which are '1's from the signal itself. This ambiguity will be resolved at a later stage when the full Navigation Message is interpreted.

PSEUDORANGE MEASUREMENT

The measurement data registers provide the raw data necessary to compute the pseudorange. This raw data is a sample, at a given instant set by the GP1020 TIC, of the 20 ms and 1 ms epoch counters, the C/A code phase counter and the code DCO phase. By definition, the pseudorange is expressed in time units and is equal to the satellite-to-receiver propagation delay plus the user clock bias. The user clock bias is first estimated (blind guessed is more likely with a cold start, but iteration then takes longer) and then obtained as a by-product of the navigation solution. The pseudorange is equal to the user's apparent local time of reception of the signal (t_1) minus the GPS real time of transmission (t_2).

With the demodulated data, the software has access to the

Space Vehicle Navigation Message, which contains information on the GPS system time for the transmission of the current subframe; this is equal to term t_2 .

The time information in the navigation message allows the receiver time to be initialised with a resolution of 20 milliseconds (one data bit period) but with knowledge of the precision to much better than one C/A code chip—a little less than 1 microsecond. As the time-of-flight from the satellite to the receiver is in the region of 60 to 80 milliseconds an improved first guess for local time could include an allowance for this delay to reduce the iteration time later.

By using the data to time-tag the TIC, along with the values of the Epoch counter, the Code generator phase, and the Code clock phase it is possible to measure the time of the SV signal in local apparent time. This gives the value of t_1 needed for the pseudorange measurement. The pseudorange can now be computed as $t_1 - t_2$.

The error present in the time setting is the initial value of the user clock bias, with an allowance for the various counter phases. Once a Navigation Solution has been found the clock error is precisely known and may be used for future pseudorange calculations. Because the receiver clock drifts with time, the clock bias changes with time and must be tracked by the Navigation software.

GP1020 REGISTER ADDRESSES AND CONTENT

Overall Memory Map

The GP1020 internal registers are addressed using 8 address lines, A1 to A8. This section gives an overview of the register names with their addresses. A detailed memory map is shown in the Table of Registers.

Address range (Hex)	Register Block accessed
00 to 07	Access to control registers of tracking channel 1
10 to 17	Access to control registers of tracking channel 2
20 to 27	Access to control registers of tracking channel 3
30 to 37	Access to control registers of tracking channel 4
40 to 47	Access to control registers of tracking channel 5
50 to 57	Access to control registers of tracking channel 6
70 to 77	For write operations only. Access to all identical control registers of all tracking channels with one single operation. The same data gets written in these registers.
80 to 83	Access to Accumulated Data and Measurement Data Status
84 to 9B	Access to In Phase and Quad Phase accumulated data registers and SBR (Status Bit Reset) commands of all tracking channels.
9C,9D	Access to all identical SBR (Status Bit Reset) commands of all tracking channels with a single write operation.
A0 to B7	Access to measurement data registers of all tracking channels.
BC to BF	For write operations only. Access to all identical measurement data registers of all tracking channels with one single operation. The same data gets written in these registers.
C0 to C8	Access to BITE interface, TIME_BASE_GEN, RESET_CNTL, signal selector and test registers.

Other addresses not used. Do not access these addresses.

Note 1: Registers are not all READ/WRITE. To minimise the hardware, some addresses are shared between read-only and write-only registers having different functions. Refer to TABLE OF REGISTERS for more details.

TABLE OF REGISTERS

Address (Hex)	Register	
	Read function	Write function
00	CH1_CNTL	CH1_CNTL
01	CH1_TST_CODE_SLEW	CH1_SIG_SEL
02	CH1_EPOCH_CHK	CH1_CODE_INCR_HI
03	CH1_SHIFT_REG	CH1_CODE_INCR_LO
04	not used	CH1_CARR_INCR_HI
05	not used	CH1_CARR_INCR_LO
06	not used	CH1_TST_CODE_PHASE
07	not used	CH1_TST_CYCLE
08	not used	not used
09	not used	not used
0A	not used	not used
0B	not used	not used
0C	not used	not used
0D	not used	not used
0E	not used	not used
0F	not used	not used
10	CH2_CNTL	CH2_CNTL
11	CH2_TST_CODE_SLEW	CH2_SIG_SEL

Continued...

TABLE OF REGISTERS (continued)

Address (Hex)	Register	
	Read function	Write function
12	CH2_EPOCH_CHK	CH2_CODE_INCR_HI
13	CH2_SHIFT_REG	CH2_CODE_INCR_LO
14	not used	CH2_CARR_INCR_HI
15	not used	CH2_CARR_INCR_LO
16	not used	CH2_TST_CODE_PHASE
17	not used	CH2_TST_CYCLE
18	not used	not used
19	not used	not used
1A	not used	not used
1B	not used	not used
1C	not used	not used
1D	not used	not used
1E	not used	not used
1F	not used	not used
20	CH3_CNTL	CH3_CNTL
21	CH3_TST_CODE_SLEW	CH3_SIG_SEL
22	CH3_EPOCH_CHK	CH3_CODE_INCR_HI
23	CH3_SHIFT_REG	CH3_CODE_INCR_LO
24	not used	CH3_CARR_INCR_HI
25	not used	CH3_CARR_INCR_LO
26	not used	CH3_TST_CODE_PHASE
27	not used	CH3_TST_CYCLE
28	not used	not used
29	not used	not used
2A	not used	not used
2B	not used	not used
2C	not used	not used
2D	not used	not used
2E	not used	not used
2F	not used	not used
30	CH4_CNTL	CH4_CNTL
31	CH4_TST_CODE_SLEW	CH4_SIG_SEL
32	CH4_EPOCH_CHK	CH4_CODE_INCR_HI
33	CH4_SHIFT_REG	CH4_CODE_INCR_LO
34	not used	CH4_CARR_INCR_HI
35	not used	CH4_CARR_INCR_LO
36	not used	CH4_TST_CODE_PHASE
37	not used	CH4_TST_CYCLE
38	not used	not used
39	not used	not used
3A	not used	not used
3B	not used	not used
3C	not used	not used
3D	not used	not used
3E	not used	not used
3F	not used	not used
40	CH5_CNTL	CH5_CNTL
41	CH5_TST_CODE_SLEW	CH5_SIG_SEL
42	CH5_EPOCH_CHK	CH5_CODE_INCR_HI
43	CH5_SHIFT_REG	CH5_CODE_INCR_LO
44	not used	CH5_CARR_INCR_HI
45	not used	CH5_CARR_INCR_LO
46	not used	CH5_TST_CODE_PHASE
47	not used	CH5_TST_CYCLE
48	not used	not used
49	not used	not used
4A	not used	not used
4B	not used	not used
4C	not used	not used
4D	not used	not used
4E	not used	not used
4F	not used	not used

TABLE OF REGISTERS (continued)

Address (Hex)	Register	
	Read function	Write function
50	CH6_CNTL	CH6_CNTL
51	CH6_TST_CODE_SLEW	CH6_SIG_SEL
52	CH6_EPOCH_CHK	CH6_CODE_INCR_HI
53	CH6_SHIFT_REG	CH6_CODE_INCR_LO
54	not used	CH6_CARR_INCR_HI
55	not used	CH6_CARR_INCR_LO and ADD_DAT_TST
56	not used	CH6_TST_CODE_PHASE
57	not used	CH6_TST_CYCLE
58	not used	not used
59	not used	not used
5A	not used	not used
5B	not used	not used
5C	not used	not used
5D	not used	not used
5E	not used	not used
5F	not used	not used
60 to 6F	not used	not used
70	not used	ALL_CNTL
71	not used	ALL_SIG_SEL
72	not used	ALL_CODE_INCR_HI
73	not used	ALL_CODE_INCR_LO
74	not used	ALL_CARR_INCR_HI
75	not used	ALL_CARR_INCR_LO
76	not used	ALL_TST_CODE_PHASE
77	not used	ALL_TST_CYCLE
78	not used	not used
79	not used	not used
7A	not used	not used
7B	not used	not used
7C	not used	not used
7D	not used	not used
7E	not used	not used
7F	not used	not used
80	MEAS_STATUS_A	STATUS LATCH
81	MEAS_STATUS_B	not used
82	ACCUM_STATUS_A	not used
83	ACCUM_STATUS_B	not used
84	CH1_I_DITH	CH1_MEAS_RST
85	CH1_Q_DITH	CH1_ACCUM_RST
86	CH1_I_PROMPT	not used
87	CH1_Q_PROMPT	not used
88	CH2_I_DITH	CH2_MEAS_RST
89	CH2_Q_DITH	CH2_ACCUM_RST
8A	CH2_I_PROMPT	not used
8B	CH2_Q_PROMPT	not used
8C	CH3_I_DITH	CH3_MEAS_RST
8D	CH3_Q_DITH	CH3_ACCUM_RST
8E	CH3_I_PROMPT	not used
8F	CH3_Q_PROMPT	not used
90	CH4_I_DITH	CH4_MEAS_RST
91	CH4_Q_DITH	CH4_ACCUM_RST
92	CH4_I_PROMPT	not used
93	CH4_Q_PROMPT	not used
94	CH5_I_DITH	CH5_MEAS_RST
95	CH5_Q_DITH	CH5_ACCUM_RST
96	CH5_I_PROMPT	not used
97	CH5_Q_PROMPT	not used
98	CH6_I_DITH	CH6_MEAS_RST
99	CH6_Q_DITH	CH6_ACCUM_RST

Continued...

TABLE OF REGISTERS (continued)

Address (Hex)	Register	
	Read function	Write function
9A	CH6_I_PROMPT	not used
9B	CH6_Q_PROMPT	not used
9C	not used	ALL_MEAS_RST
9D	not used	ALL_ACCUM_RST
9E	not used	not used
9F	not used	not used
A0	CH1_EPOCH_A	CH1_1MS_EPOCH
A1	CH1_EPOCH_B	CH1_PRESET_PHASE
A2	CH1_CARR_DCO_PHASE	CH1_CODE_SLEW
A3	CH1_CARR_CYCLE	CH1_20MS_EPOCH
A4	CH2_EPOCH_A	CH2_1MS_EPOCH
A5	CH2_EPOCH_B	CH2_PRESET_PHASE
A6	CH2_CARR_DCO_PHASE	CH2_CODE_SLEW
A7	CH2_CARR_CYCLE	CH2_20MS_EPOCH
A8	CH3_EPOCH_A	CH3_1MS_EPOCH
A9	CH3_EPOCH_B	CH3_PRESET_PHASE
AA	CH3_CARR_DCO_PHASE	CH3_CODE_SLEW and ADD_DAT_TST
AB	CH3_CARR_CYCLE	CH3_20MS_EPOCH
AC	CH4_EPOCH_A	CH4_1MS_EPOCH
AD	CH4_EPOCH_B	CH4_PRESET_PHASE
AE	CH4_CARR_DCO_PHASE	CH4_CODE_SLEW
AF	CH4_CARR_CYCLE	CH4_20MS_EPOCH
B0	CH5_EPOCH_A	CH5_1MS_EPOCH
B1	CH5_EPOCH_B	CH5_PRESET_PHASE
B2	CH5_CARR_DCO_PHASE	CH5_CODE_SLEW
B3	CH5_CARR_CYCLE	CH5_20MS_EPOCH
B4	CH6_EPOCH_A	CH6_1MS_EPOCH
B5	CH6_EPOCH_B	CH6_PRESET_PHASE
B6	CH6_CARR_DCO_PHASE	CH6_CODE_SLEW
B7	CH6_CARR_CYCLE	CH6_20MS_EPOCH
B8	not used	not used
B9	not used	not used
BA	not used	not used
BB	not used	not used
BC	not used	ALL_1MS_EPOCH
BD	not used	ALL_PRESET_PHASE
BE	not used	ALL_CODE_SLEW
BF	not used	ALL_20MS_EPOCH
C0	RESET_CNTL	RESET_CNTL
C1	BITE	BITE
C2	RTC_DELAY	TIMER_CNTL
C3	PROP_DELAY_LO	DOWN_COUNT_HI
C4	PROP_DELAY_HI	DOWN_COUNT_LO
C5	STAT_CHK_SIGN	STAT_CHK_SEL
C6	STAT_CHK_MAG	not used
C7	ADD_DAT_TST	ADD_DAT_TST
C8	not used	TDATA_DUTY_CYCLE
C9 to FF	not used	not used

DETAILED DESCRIPTION OF REGISTERS

The registers are listed in alphabetical order and not in address order to allow easy reference to each section.

ACCUM_STATUS_A Read Address 82_H

Register bit mapping	
Bit	Bit name
LSB 0	CH1_NEW_ACCUM_DATA
1	CH2_NEW_ACCUM_DATA
2	CH3_NEW_ACCUM_DATA
3	CH4_NEW_ACCUM_DATA
4	CH5_NEW_ACCUM_DATA
5	CH6_NEW_ACCUM_DATA
6	not used
7	not used
8	CH1_EARLY_LATEB
9	CH2_EARLY_LATEB
10	CH3_EARLY_LATEB
11	CH4_EARLY_LATEB
12	CH5_EARLY_LATEB
13	CH6_EARLY_LATEB
14	not used
MSB 15	NEW_STAT_DATA

REGISTER OPERATION

ACCUM_STATUS_A is a latch register containing the state of status bits prevailing at time of sampling. The status bits are sampled and latched on the positive edge of every INT OUT or INT IN signal. They can also be sampled and latched on request by performing a write operation to STATUS_LATCH (location 80_H). Latching the status bits ensures glitch-free reading of ACCUM_STATUS_A.

BIT DESCRIPTION

The following bits are all active HIGH:

CHx_NEW_ACCUM_DATA status bit indicates if there is new accumulated data available to be read. Each individual bit can be cleared with a write operation at CHx_ACCUM_RESET location or by disabling the propagation of clocks (CHx_RSTB bits of RESET_CNTL). This also releases the overwrite protection.

Each bit is also cleared on the trailing edge of a read of the associated Q_PROMPT register. If new accumulated data becomes available after ACCUM_STATUS_A bits have been latched, the overwrite protection is not cleared while reading the Q_PROMPT register and the CHx_NEW_ACCUM_DATA bit will be set at the next latching of ACCUM_STATUS_A.

CHx_EARLY_LATEB status bit indicates whether the accumulated data on the dithering arm of the tracking channel results from correlation with early or late code. A HIGH indicates an EARLY code and a LOW indicates a LATE code. Each individual bit is updated at each DUMP when the overwrite protection is not active. When the Early-Minus-Late code is selected for a particular channel, this status bit has no meaning.

NEW_STAT_DATA status bit when HIGH indicates that new statistical data is available in the STAT_CHK_SIGN and STAT_CHK_MAG registers. It is cleared when a STAT_CHK_MAG read operation is performed if a valid state had been latched previously or by a write operation at ALL_ACCUM_RESET location. The first statistical data after a power up is not representative and should be cleared. All status bits are reset by a hardware or software master reset.

ACCUM_STATUS_B Read Address 83_H

Register bit mapping	
Bit	Bit name
LSB 0	CH1_MISSED_ACCUM
1	CH2_MISSED_ACCUM
2	CH3_MISSED_ACCUM
3	CH4_MISSED_ACCUM
4	CH5_MISSED_ACCUM
5	CH6_MISSED_ACCUM
6	not used
7	not used
8	CH1_OVFL_ACCUM
9	CH2_OVFL_ACCUM
10	CH3_OVFL_ACCUM
11	CH4_OVFL_ACCUM
12	CH5_OVFL_ACCUM
13	CH6_OVFL_ACCUM
14	not used
MSB 15	not used

REGISTER OPERATION

ACCUM_STATUS_B bits are sampled and latched on the positive edge of every INT OUT or INT IN signal. They can also be sampled and latched on request by performing a write operation to STATUS_LATCH (location 80_H).

BIT DESCRIPTION

CHx_MISSED_ACCUM status bit indicates if there has been missed accumulated data. When active HIGH, this status bit is latched until (i) a master reset (hardware or software) or (ii) a write operation to CHx_ACCUM_RESET with don't care data or (iii) the propagation of clocks is disabled (CHx_RSTB bits of RESET_CNTL).

CHx_OVFL_ACCUM status bit indicates if there has been an overflow in any of the channel accumulated data registers. This bit is active HIGH and is updated at each DUMP when the overwrite protection is not active. It gets reset whenever the associated CHx_ACCUM_RESET is written into with don't care data or upon a master reset (hardware or software) or by disabling the propagation of clocks (CHx_RSTB bits of RESET_CNTL).

ADD_DAT_TST Read/Write Address C7_H

This register is used to test the address bus and data bus hardware connections to the inputs of the chip. It allows the system to verify that there is no short between pins or input lines in the chip or on the board.

Register bit mapping	
Bit	Description
15 to 8	Contents of address bus or most significant bits of data bus.
7 to 0	Contents of least significant bits of data bus.

REGISTER OPERATION

This register is a read/write register. Upon a master reset (software or hardware) the register is cleared. When a write is performed at address AA_H or 55_H the most significant bits of the register will be loaded with the address bus value present on the bus, AA_H or 55_H if the address bus is working properly and the least significant bits of the register will keep their previous value.

GP1020

When a write is performed at address C7_H the register will be loaded with the data bus value present on the bus.

When a read operation is performed to C7_H it reads all the bits previously loaded.

It is recommended that the test is performed as follows in order to verify that the address and data bus operate properly.

Address Bus Test:

- Write to address 55_H (the data bits are don't care)
- Read the most significant bits at address C7_H (the 8 least significant bits are 00_H if no access had been done to the address C7_H). If the value is not 5500_H a problem is detected on the address bus.
- Write to address AA_H (the data bits are don't care)
- Read the most significant bits at address C7_H. If the value is not AA00_H a problem is detected on the address bus.

NOTE : When writing to addresses 55_H and AA_H, the CH6_CARR_INCR_LO and CH3_CODE_SLEW registers will also be written into with the values on the data bus.

Data Bus Test:

- Write 5555_H to address C7_H
- Read the register at address C7_H. If the value is not 5555_H a problem is detected on the data bus.
- Write AAAA_H to address C7_H
- Read the register at address C7_H. If the value is not AAAA_H a problem is detected on the data bus.

BITE Read/Write Address C1_H

Register bit mapping	
Bit	Description
0	BITECNTL
1	DISCOP
2	PLL_LOCKA (state)
3	PLL_LOCKB (negative transition)
4	GLONASS BIT
5	SELF_TEST_EN
6	SELF_TEST_SOURCE
7	MEANDER
8	CARR_MIX_ENB

BIT DESCRIPTION

BITECNTL bit: Drives the BITE input of the GP1010. Set inactive LOW by a Master Reset. When HIGH, the GP1010's PLL is unlocked and the 40 MHz signal becomes unstable. The GP1020 should be put into hardware master reset mode for the time needed to allow the GP1010's 40 MHz output to stabilise.

DISCOP: Discrete output with no specific function. LOW at power up and its state will follow the value written in the BITE register.

PLL_LOCKA: input from GP1010, Read only, to indicate the state of the PLL LOCK signal; a HIGH indicates a locked condition. This discrete input can be used for other purposes.

PLL_LOCKB: input from GP1010, indicates that a negative transition of the PLL LOCK signal (from locked to unlocked state) has been detected and latched in the GP1020. A HIGH indicates a negative transition. This bit is cleared by the trailing edge of a read to BITE register operation.

GLONASS BIT: TEST input from GLONASS front end. A HIGH on this pin sets register bit HIGH. This discrete input can also be used for other purposes.

SELF_TEST_EN: active HIGH. When inactive (LOW) the

self-test signal generator is disabled and TSIGN and TMAG output pins are held LOW. When active the self-test signal generator is enabled and TSIGN and TMAG output pins are toggling. The injection back into the input of the tracking channels is controlled by CHx_SIGNAL_SEL.

SELF_TEST_SOURCE: When LOW, the tracking channel 1 is used as a signal source for the self-test signal generator. When HIGH, the tracking channel 2 is used as a signal source for the self-test signal generator.

MEANDER: When HIGH, the self-test generator will modulate the data bit stream with a meander. This is required when GLONASS operation has to be tested.

CARR_MIX_ENB: When LOW, all carrier mixers operate normally. When HIGH, all carrier mixers are disabled and the incoming sign and magnitude data passes through without being affected.

CHx_ACCUM_RESET Write Addresses 85, 89, 8D, 91, 95, 99_H and ALL_ACCUM_RESET Write Address 9D_H

These are write-only locations provided to allow resetting of all the status bits associated with a given channel in ACCUM_STATUS_A and ACCUM_STATUS_B. ALL_ACCUM_RESET access will also clear the NEW_STAT_DATA flag in ACCUM_STATUS_B register. When these locations are written into, the data is don't care. But if the CNTTESTMODE bit (CHx_20MS_EPOCH register) is active, G1 and G2 registers will be set at the 1023rd chip of the code sequence. This operation accelerates the test process by generating accumulated data and status bits when the code steps to the first chip and so generating a DUMP in the associated channel.

CHx_CARR_CYCLE Read Addresses A3, A7, AB, AF, B3, and B7_H

This register contains the 16 more significant bits of a variable containing the number of CARRIER DCO cycles that occurred during the last TIC period ending at a TIC. The value is sampled and latched on the TIC. While reading measurement data associated with a given channel, CHx_CARR_CYCLE must be read last because the trailing edge of a read to this register will release the overwrite protection mechanism of measurement data for this channel.

CARR_CYCLE: PRINCIPLE OF OPERATION

In the CHx_CARR_CYCLE register and counter a TIC generates two consecutive actions:

1. It latches the 16 more significant bits of the cycle up counter into CARR_CYCLE and the 2 less significant bits into CARR_DCO_PHASE.
2. It resets the cycle up counter.

After each TIC, every time the carrier DCO accumulator generates an OVERFLOW as a result of a carrier cycle being completed, the cycle up counter counts up by one. The number of bits needed for the counter was established as follows:

For GPS, the nominal CARRIER DCO frequency with no Doppler and no oscillator drift compensation is 1·405396825 MHz, so in 100 ms, there will be about 140,540 cycles. For GLONASS signals, the carrier DCO frequency will vary depending on the particular satellite being tuned, between 1·429 - 0·6 MHz and 1·429 + 0·6 MHz, a maximum of 2·029 MHz, giving 202,900 cycles in 100 ms.

The maximum number of cycles, CARR_COUNT MAX, will also depend on the maximum Doppler and oscillator drift compensation to be allowed for, hence the counter must be able to count to a number greater than 140,540 or 202,900.

The highest frequency required is then 2·029 MHz plus a few

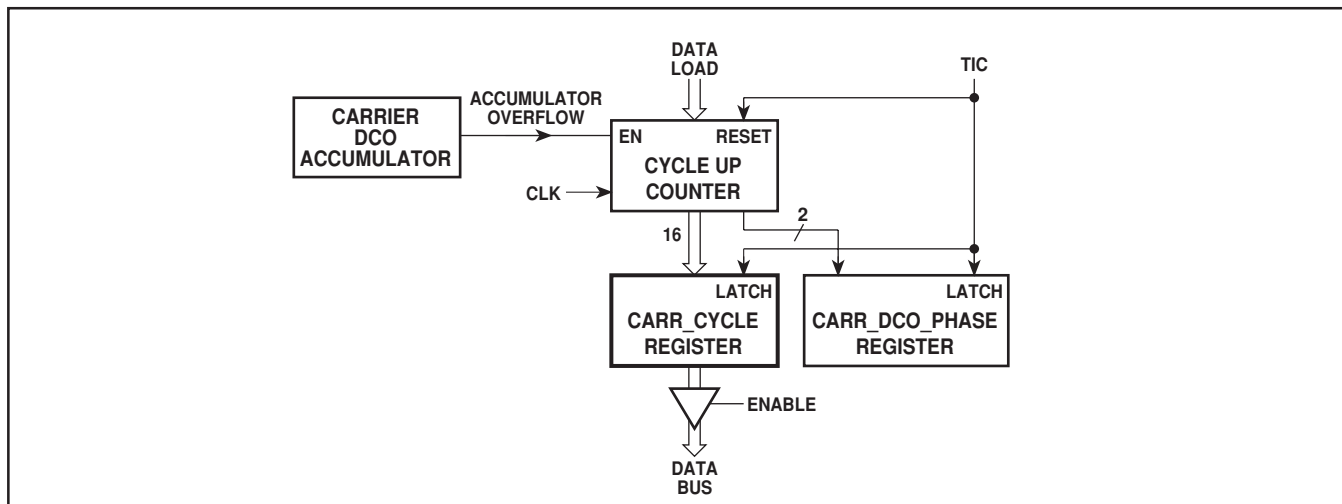

Fig. 13 CH_x_CARR_CYCLE block diagram

tens of kilohertz to allow for oscillator drift and Doppler compensation. An 18 bit counter will cover up to 262,143 cycles, which is more than adequate.

REGISTER CONTENTS RANGE

CH_x_CARR_CYCLE is a 16 bit register, unsigned, and the validity range of the data is 0 to 2¹⁶-1.

CH_x_CARR_CYCLE content is protected by the overwrite protection mechanism of measurement data. Thus for an overwrite to occur, either the associated CH_x_NEW_MEAS_DATA status bit has to be cleared or CH_x_CARR_CYCLE itself has to be read.

CH_x_CARR_DCO_PHASE Read Addresses A2, A6, AA, AE, B2, B6

Register bit mapping	
Bit	Description
9 to 0	Most significant bits of CH _x _CARR_DCO phase accumulator. The weight of the least significant bit is 2π/1024 radian. These bits form an unsigned integer valid from 0 to 1023. CH _x _CARR_DCO_PHASE provides the sub-cycle integrated phase measurement information and therefore complements the information given by CH _x _CARR_CYCLE
11 and 10	Least significant bits of the number of carrier DCO cycles that occurred during the last TIC period ending at a TIC. The value is sampled and latched on the TIC.
15 to 12	Not used.

The register value is latched on a TIC and protected from overwrite by the overwrite protection mechanism of measurement data.

CH_x_CARR_INCR_HI & CH_x_CARR_INCR_LO and ALL_CARR_INCR_HI & ALL_CARR_INCR_LO Write Addresses 04 & 05, 14 & 15, 24 & 25, 34 & 35, 44 & 45, 54 & 55 and 74 & 75_H

Register bit mapping	
Bit	Description
CARR_INCR_HI 9 to 0	More significant bits of the Carrier DCO phase increment.
CARR_INCR_LO 15 to 0	Less significant bits of the Carrier DCO phase increment.

REGISTER OPERATION

The registers CARR_INCR_LO and CARR_INCR_HI are combined to form the 26 bits of the CARR_INCR register, the carrier DCO phase increment. Both registers are write-only registers and can be written to at any time. The first write must be performed on CARR_INCR_HI and the second write on CARR_INCR_LO. The written value is latched in the CARR_INCR register on the trailing edge of a write to CARR_INCR_LO. It is possible to perform a write only to CARR_INCR_LO register if the CARR_INCR_HI value does not need to be updated.

The DCO adder is 27 bits wide and the LSB of the INCR register represents a step given by:

$$\text{Min. Step Freq.} = (40\text{MHz}/7) \times 2^{-27} = 42.57475 \text{ milliHertz}$$

and the output frequency is:

$$\text{Freq. out} = \text{CH}_x\text{_CARR_INCR reg. value} \times \text{Min. Step Freq.}$$

The nominal value of the CH_x_CARR_INCR register for GPS is 01F7 B1B9_H (to get a carrier at 1.405396825 MHz when the GP1010 clock signal is at 40 MHz).

GP1020

CHx_CODE_INCR_HI & CHx_CODE_INCR_LO and ALL_CODE_INCR_HI & ALL_CODE_INCR_LO

Write Addresses 02 & 03, 12 & 13, 22 & 23, 32 & 33, 42 & 43, 52 & 53 and 72 & 73_H

Register bit mapping	
Bit	Description
CODE_INCR_HI 8 to 0	More significant bits of the Code DCO phase increment.
CODE_INCR_LO 15 to 0	Less significant bits of the code DCO phase increment.

CODE_INCR_LO. The written value is latched in the CODE_INCR register on the trailing edge of a write to CODE_INCR_LO. It is possible to perform a write only to CODE_INCR_LO register if the CODE_INCR_HI value does not need to be updated.

The DCO adder is 26 bits wide and the LSB of the INCR register represents a step given by:

$$\text{Min. Step Freq.} = (40\text{MHz}/7) \times 2^{-26} = 85.14949 \text{ milliHertz}$$

and the output Frequency is:

$$\text{Freq. out} = \text{CHx_CODE_INCR reg. value} \times \text{Min. Step Freq.}$$

NOTE: The CODE DCO drives the CODE GENERATOR to give half-chip time steps and so must be programmed to twice the required chip rate. This means that the chip rate resolution is 42.57475 milliHertz.

The nominal value of the CHx_CODE_INCR register for GPS is 016E A4A8_H (to get a chip rate of 1.023MHz when the GP1010 clock signal is at 40 MHz).

REGISTER OPERATION

The registers CODE_INCR_LO and CODE_INCR_HI are combined to form the 25 bits of the CODE_INCR register, the code DCO phase increment. Both registers are write-only registers and can be written to at any time. The first write must be performed on CODE_INCR_HI and the second write on

CHx_CNTL and ALL_CNTL Read/Write Addresses 00, 10, 20, 30, 40, 50, and 70_H

Register bit mapping		
Bit	Operation mode of CHx_CNTL reg. (Set by bit 15)	Description
7 to 0 9 to 0	MODE1 MODE2	C/A CODE SELECTION FUNCTION (see details below)
9 and 8	MODE1	CODESEL(0:1):selects the appropriate code to be shifted out of the dithering arm output of the code generator as follows: 9 = 0 8 = 0 Early code 9 = 0 8 = 1 Late code 9 = 1 8 = 0 Dithering code 9 = 1 8 = 1 Early minus late code
10	MODE1&2	GLO/GPSB: Selects the code type to be generated. GLONASS C/A code when HIGH, GPS or INMARSAT C/A code when LOW.
11	MODE1&2	CODE_OFF/ONB: When LOW, the code is output normally, but when HIGH, the Prompt, Early and Late codes are held HIGH (no effect on the mixer outputs) and the Early-minus-late code is held LOW to mask mixer outputs and force I&D input values to 0.
12	MODE1&2	PRESET/UPDB: While HIGH, Programs the channel to Preset mode, or while LOW, programs the channel to Update mode.
14 and 13 14 and 13	MODE1 MODE2	not used - don't care CODESEL(0:1) As bits 9 and 8 MODE1.
15	—	MODE: When LOW the CNTL register is in MODE1 (power up condition) and when HIGH in MODE2. When in MODE1, the selection of a C/A code is done by selecting two taps of the G2 register, but in MODE2 by presetting the value of the G2 register. The function of bits 8 and 9 will change depending on the MODE.

REGISTER OPERATION

CHx_CNTL can be written into at any time and any modification to its content is effective immediately (within 250 ns) while in UPDATE mode, or for all bits except PRESET/UPDB at the next TIC while in PRESET mode. Before reading the content of this register, it is necessary to wait 250 ns after the last write

operation when in UPDATE mode. Only the PRESET bit is available immediately but it is cleared 150ns after the PRESET sequence has taken place (at the TIC following the initialisation of CHx_20MS_EPOCH register). It is important to program this register first when starting a PRESET initialisation sequence.

C/A CODE SELECTION

The CHx_CNTL register allows two different modes of programming the CODE GENERATOR :

MODE 1: select the appropriate taps of G2 to generate the GPS C/A code.

MODE 2: set the G2 register with the appropriate pattern to generate the GPS or INMARSAT C/A codes.

NOTE: When in MODE 2, the G2 register should be loaded with a value representing its state at the time of the second chip.

The difference between the two modes of programming the C/A code is that MODE 2 allows the CODE GENERATOR to synthesise the 8 INMARSAT C/A codes and MODE 1 does not, but is more straightforward.

The following table gives the pattern of bits 3 to 0 or 7 to 4 to select a particular tap (used in MODE 1 of the CHx_CNTL register) :

Bit Pattern	Tap
0000	1
0001	2
0010	3
0011	4
0100	5
0101	6
0110	7
0111	8
1xx0	9
1xx1	10

The table below shows the bit setting required to select the appropriate taps which will decode the 37 possible GPS PRN signal numbers when in MODE 1 and the bit setting required to set the G2 register in the second chip state for all GPS and INMARSAT C/A codes when in MODE 2.

Note that the list does not show all the possible tap and bit setting combinations. Tap combinations which are not listed can also be used if required.

GPS PRN signal no.	MODE 1 bit setting 7 to 0	Selected taps	MODE 2 bit setting 9 to 0
1	0001 0101	2 EXOR 6	3F6 _H
2	0010 0110	3 EXOR 7	3EC _H
3	0011 0111	4 EXOR 8	3D8 _H
4	0100 1xx0	5 EXOR 9	3B0 _H
5	0000 1xx0	1 EXOR 9	04B _H
6	0001 1xx1	2 EXOR 10	096 _H
7	0000 0111	1 EXOR 8	2CB _H
8	0001 1xx0	2 EXOR 9	196 _H
9	0010 1xx1	3 EXOR 10	32C _H
10	0001 0010	2 EXOR 3	3BA _H
11	0010 0011	3 EXOR 4	374 _H
12	0100 0101	5 EXOR 6	1D0 _H
13	0101 0110	6 EXOR 7	3A0 _H
14	0110 0111	7 EXOR 8	340 _H
15	0111 1xx0	8 EXOR 9	280 _H
16	1xx0 1xx1	9 EXOR 10	100 _H
17	0000 0011	1 EXOR 4	113 _H
18	0001 0100	2 EXOR 5	226 _H
19	0010 0101	3 EXOR 6	04C _H
20	0011 0110	4 EXOR 7	098 _H
21	0100 0111	5 EXOR 8	130 _H
22	0101 1xx0	6 EXOR 9	260 _H

GPS PRN signal no.	MODE 1 bit setting 7 to 0	Selected taps	MODE 2 bit setting 9 to 0
23	0000 0010	1 EXOR 3	267 _H
24	0011 0101	4 EXOR 6	120 _H
25	0100 0110	5 EXOR 7	270 _H
26	0101 0111	6 EXOR 8	0E0 _H
27	0110 1xx0	7 EXOR 9	1C0 _H
28	0111 1xx1	8 EXOR 10	380 _H
29	0000 0101	1 EXOR 6	22B _H
30	0001 0110	2 EXOR 7	056 _H
31	0010 0111	3 EXOR 8	0AC _H
32	0011 1xx0	4 EXOR 9	158 _H
33	0100 1xx1	5 EXOR 10	2B0 _H
34 *	0011 1xx1	4 EXOR 10	058 _H
35	0000 0110	1 EXOR 7	18B _H
36	0001 0111	2 EXOR 8	316 _H
37 *	0011 1xx1	4 EXOR 10	058 _H
201	n/a n/a	n/a	2C4 _H
202	n/a n/a	n/a	10A _H
205	n/a n/a	n/a	3E3 _H
206	n/a n/a	n/a	0F8 _H
207	n/a n/a	n/a	25F _H
208	n/a n/a	n/a	1E7 _H
209	n/a n/a	n/a	2B5 _H
211	n/a n/a	n/a	10E _H

*C/A Codes 34 and 37 are common

NOTE: PRN sequences 33 to 37 are reserved for other uses (e.g. ground transmitters).

The table below lists the required setting of the register bit 0 to generate the GLONASS C/A code or the GLONASS-like test C/A code. Note that bit 10 must be HIGH to select GLONASS rather than GPS codes.

Bit 0 setting MODE 1 & 2	Code type	Selected G1 taps
0	GLONASS	5 EXOR 9
1	GLONASS TEST	3 EXOR 5 EXOR 6 EXOR 9

In update mode, the C/A code generated by the CODE GENERATOR can be changed at any time but the next accumulated data following the command will not be valid. The MODE bit cannot be modified without disabling the clock phases when in UPDATE mode otherwise the C/A code generated will not be valid. This is not the case when starting a PRESET sequence.

To provide a clean switch between GLONASS and GPS modes of operation for a specific channel, it is necessary to proceed as follows: Disable propagation of the clock phases to this tracking channel by selecting the appropriate bit in the RESET_CNTL register, then select the desired mode of operation GLONASS or GPS and re-enable the propagation of the clock phases. If the clock phases propagation are not disabled, the next accumulated data will not be valid.

When the dithering code has been selected, the dithering arm will use the EARLY code for a period of 20 C/A codes, the LATE code for the next 20 C/A codes and this process of dithering between EARLY and LATE code will be repeated indefinitely. The dithering arm will use the EARLY code for the first 20 ms EPOCH following a SLEW or a PRESET operation.

Upon MASTERRESET, CHx_CNTL bits are set to the states given in the following Table.

Bit	State	Description
7 to 0	03 _H	GPS PRN No. 17 selected.
9 and 8	00	Early Code on the dithering arm.
10	0	GPS C/A CODE
11	0	CODE ON
12	0	UPDATE MODE
14 and 13	00	N/A (MODE1)
15	0	MODE1

CHx_CODE_SLEW and ALL_CODE_SLEW Write Addresses A2, A6, AA, AE, B2, B6 and BE_H

Register bit mapping	
Bit	Description
10 to 0	Unsigned integer ranging from 0 to 2047 representing the number of code half chips to be slewed after the next DUMP if in UPDATE MODE or after the next TIC, if in PRESET MODE. Since there are only 2046 half chips in a GPS C/A code, a programmed value of 2047 is equivalent to a programmed value of 1 but the next DUMP event will take place 1 ms later. For the GLONASS code a similar wrap-around will occur at 1023 and 2045.

The CHx_CODE_SLEW register can be written to at any time. If two accesses have taken place before a DUMP in UPDATE mode or before a TIC when in PRESET mode, the latest value will be used at the next slew operation.

When the slew process is being executed, a write access to the CHx_CODE_SLEW register will cause the transfer of this new value into the counter and will be used immediately. The result is not predictable. This situation should be avoided by synchronising the access with the associated CHx_NEW_ACCUM_DATA status bit.

Slew timing details are shown in Figs. 14 and 15.

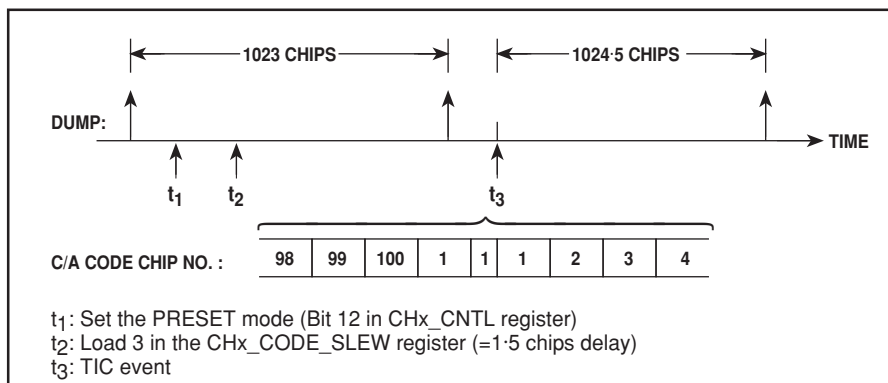
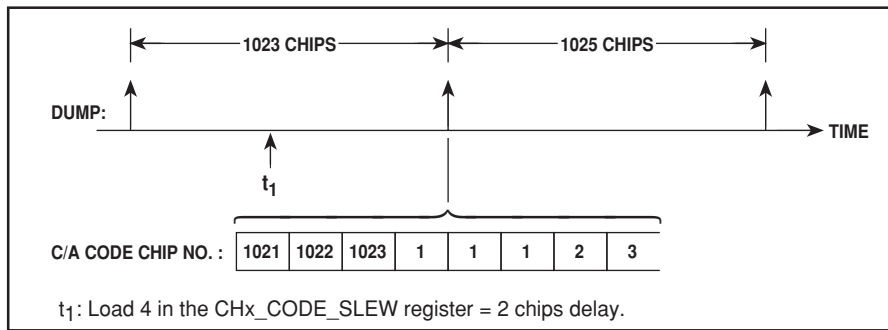

CHx_EPOCH_A**Read Addresses A0, A4, A8, AC, B0, B4_H**

This register contains the variables as detailed below.

Register bit mapping	
Bit	Description
15 to 11	CHx_1MS_EPOCH: The one millisecond epoch counter value sampled at TIC event. Its valid range is 0 to 19.
10 to 0	CHx_CODE_PHASE: Represents the code phase of the code generator when sampled and latched on a TIC, expressed as a number of half code chips. It ranges from 0 to 2045 when a GPS C/A code is generated and from 0 to 1021 when a GLONASS C/A code is generated.

CHx_EPOCH_A content is protected from overwrite by the overwrite protection mechanism of measurement data.

CHx_EPOCH_B**Read Addresses A1, A5, A9, AD, B1, B5_H**

The register contains two variables as detailed below:

Register bit mapping	
Bit	Description
15 and 14	Not used.
13 to 8	CHx_20MS_EPOCH: Contains the 20 millisecond epoch counter value sampled at TIC event. Its valid range is from 0 to 49.
7 to 0	CHx_CODE_DCO_PHASE: Contains the eight most significant bits of the code DCO phase accumulator sampled at TIC event. The weight of the least significant bit is $2\pi/256$ radians, 2π being 1/2 code chip. The byte is an unsigned integer valid from 0 to 255.

CHx_EPOCH_B content is protected from overwrite by the overwrite protection mechanism of measurement data.

CHx_EPOCH_CHK**Read Addresses 02, 12, 22, 32, 42, 52_H**

This register contains the instantaneous value of CHx_1MS_EPOCH and CHx_20MS_EPOCH. It can be used to verify if the Epoch counters have properly been initialised by the software since the timing is critical for the initialisation operation. Its value is not latched and is updated on the occurrence of a DUMP. This register should be read only when there is no possibility of getting a DUMP during the read cycle.

Register bit mapping	
Bit	Description
15 to 13	Not used.
12 to 8	Instantaneous value of CHx_1MS_EPOCH.
7	Bit 14 of CHx_CNTRL (test purpose only)
6	CNTTESTMODE bit
5 to 0	Instantaneous value of CHx_20MS_EPOCH.

CHx_I_DITH, CHx_Q_DITH, CHx_I_PROMPT, CHx_Q_PROMPT**24 consecutive Read Addresses 84 to 9B_H**

Register bit mapping	
Bit	Description
15 to 2	Accumulated data registers, which are loaded on each Dump event with the I&D accumulator results.
1	Not used, held LOW.
0	Instantaneous value of the over/underflow flag (for test purposes). Normally LOW, but HIGH if the data being accumulated in the I&D accumulator has reached the over/underflow condition.

REGISTER OPERATION

These registers are read only registers; they can be read at any time and their content is protected by the overwrite protection mechanism of accumulated data. The CHx_I_PROMPT and CHx_Q_PROMPT contain the accumulated data taken on the Prompt arm. The CHx_I_DITH and CHx_Q_DITH contain the accumulated data taken on the Dithering arm. The overwrite protection mechanism is released by reading the CHx_Q_PROMPT register.

The values contained in the registers are 2's complement values with the valid range of the data from 2^{13} for negative numbers to $(2^{13} - 1)$ for positive numbers. When an over/underflow condition is flagged (CHx_OVFL_ACCUM bit in ACCUM_STATUS_B set HIGH) the contents of the registers for this arm will be the last I&D accumulator values before the over/underflow condition happened. If bit 15 is LOW it is an overflow and if bit 15 is HIGH it is an underflow. Bits 0 of the 24 accumulated data registers have no link with the other data in these registers. When HIGH, each of these bits indicates that the data being accumulated in the I&D has reached the maximum value (positive or negative) of the accumulator and this value will be available at the next DUMP.

CHx_MEAS_RST and ALL_MEAS_RST**Write Addresses 84, 88, 8C, 90, 94, 98 and 9C_H**

A write to this location with don't care data resets all measurement data status bits contained in both MEAS_STATUS_A and MEAS_STATUS_B registers. It also clears any active overwrite protection on measurement data. ALL_MEAS_RST access will also clear the MARK_FB_ACK and the RTC_TIC_ACK flags in MEAS_STATUS_A register and the associated overwrite protections.

CHx_PRESET_PHASE and ALL_PRESET_PHASE**Write Addresses A1, A5, A9, AD, B1, B5 and BD_H**

Register bit mapping	
Bit	Description
7 to 0	Most significant bits of the Code DCO phase which is to be loaded at next TIC event if in PRESET mode.

REGISTER OPERATION

In PRESET mode, the 8 bits of the PRESET_PHASE register are added to the top 7 bits of the CHx_CODE_INCR register

GP1020

and the sum is loaded into the 8 bits of the CODE_DCO accumulator along with all zeros in the lower bits. The PRESET_PHASE register is a write only register and it can be written to at any time in PRESET mode or in UPDATE mode. The weight of the least significant bit of PRESET phase is $2\pi/256$ radian of a half chip cycle.

CHx_SHIFT_REG

Read Addresses 03, 13, 23, 33, 43, 53_H

Register bit mapping	
Bit	Description
15 to 13	Not used; don't care data
12	Bit 15 (MODE bit) of CHx_CNTL (test purpose only)
11	11th chip
10	12th chip
9	First chip
0	10th chip

REGISTER OPERATION

This register is used for test purpose only. The 12 less significant bits of the word contain the first 12-bit sequence of the C/A code issued by the channel's code generator on the dithering arm. The latching process is armed as a result of a completed slew operation, a PRESET sequence or a clock phase release by CHx_RSTB bit of the RESET_CNTL register. It is necessary to wait at least 24 Code DCO clock cycles (12 μ s in GPS mode and 24 μ s in GLONASS mode) before reading this register. The 3 most significant bits of the word are don't care data. When in Early Minus Late mode, this register will contain the first 12-bit sequence of the code sign issued on the dithering arm.

The following table contains the result of the SHIFT_REG register for all possible cases.

GPS/ GLONASS C/A code	SHIFT_REG value	
	EARLY/LATE code	EARLY-MINUS-LATE code
1	F20 _H	640 _H
2	F90 _H	A40 _H
3	FC8 _H	241 _H
4	FE4 _H	242 _H
5	25B _H	249 _H
6	32D _H	24A _H
7	E59 _H	248 _H
8	72C _H	648 _H
9	B96 _H	A4A _H
10	B44 _H	689 _H
11	FA2 _H	289 _H
12	7E8 _H	A82 _H
13	BF4 _H	294 _H
14	FFA _H	290 _H
15	FFD _H	609 _H
16	7FE _H	229 _H
17	26E _H	222 _H
18	B37 _H	221 _H
19	79B _H	225 _H
20	3CD _H	228 _H
21	3E6 _H	620 _H

GPS/ GLONASS C/A code	SHIFT_REG value	
	EARLY/LATE code	EARLY-MINUS-LATE code
22	BF3 _H	A12 _H
23	E33 _H	610 _H
24	7F6 _H	249 _H
25	FE3 _H	205 _H
26	7F1 _H	621 _H
27	3F8 _H	608 _H
28	BFC _H	242 _H
29	A57 _H	A50 _H
30	72B _H	A52 _H
31	395 _H	254 _H
32	3CA _H	250 _H
33	BE5 _H	649 _H
34 *	7CB _H	648 _H
35	25C _H	244 _H
36	B2E _H	245 _H
37 *	7CB _H	648 _H
201	BB9 _H	222 _H
202	35E _H	684 _H
205	A70 _H	A10 _H
206	3C1 _H	208 _H
207	A0B _H	A08 _H
208	630 _H	610 _H
209	AA5 _H	AA4 _H
211	71E _H	A04 _H
GLONASS	3F8 _H	201 _H
GLONASS _TEST	FF8 _H	610 _H

* Note C/A Codes 34 and 37 are the same.

CHx_SIG_SEL and ALL_SIG_SEL

Write Addresses 01, 11, 21, 31, 41, 51 and 71_H

Register bit mapping		
Bit	Description	
	Signal source selection with the following encoding: Bit 3 2 1 0	Selected input port
3 to 0	0 0 0 0	0
	0 0 0 1	1
	0 0 1 0	2
	0 0 1 1	3
	0 1 0 0	4
	0 1 0 1	5
	0 1 1 0	6
	0 1 1 1	7
	1 x 0 0	8
	1 x 0 1	9
1 x 1 0	Self test signal	
1 x 1 1	Ground	
15 to 4	Not used, don't care.	

REGISTER DESCRIPTION

CHx_SIG_SEL can be written into at any time. The SELF TEST SIGNAL is the sign and mag outputs (TSIGN and TMAG output pins) of the SELF_TEST_GENERATOR block and are wrapped round internally.

CHx_TST_CODE_PHASE and ALL_TST_CODE_PHASE

Write Addresses 06, 16, 26, 36, 46, 56 and 76_H

This location can be written into only if the CNTTESTMODE signal, in the CHx_20MS_EPOCH is HIGH and if the MSB of the CODE_DCO phase is LOW (power up condition). The CHx_TST_CODE_PHASE is an unsigned 11 bit write only register. It is used to pre-load the CODE_PHASE counter with a specific value. ALL_TST_CODE_PHASE operates only on those channels with CNTTESTMODE set high.

Register bit mapping	
Bit	Description
10 to 0	11 bits of the CODE_PHASE counter

CHx_TST_CODE_SLEW

Read Addresses 01, 11, 21, 31, 41, 51_H

This location can be read at anytime for test purposes. It gives access to actual contents of CHx_CODE_SLEW counter. It is possible to read unstable data if the counter value is changing during the read pulse.

Register bit mapping	
Bit	Description
15 to 13	Don't care
12	Bit 13 of CHx_CNTRL register (test purpose only)
11	Indicates the state of the CODE_SLEW counter (for test purpose): 0: has reached the count of zero 1: counter value is not zero and/or the counter is not enabled to count (see note)
10 to 0	Contents of CHx_CODE_SLEW

NOTE : the CODE_SLEW counter is enabled to count when it has been loaded (CHx_CODE_SLEW register) and a DUMP has occurred if in Update mode. In Preset mode, the counter is loaded and enabled to count upon a TIC event if the CHx_20MS_EPOCH had been loaded.

CHx_TST_CYCLE and ALL_TST_CYCLE

Write Addresses 07, 17, 27, 37, 47, 57 and 77_H

This location can be written into only if the CNTTESTMODE signal, in the CHx_20MS_EPOCH is active (HIGH) and if the MSB of the CARRIER_DCO phase is LOW (as at power up). The CHx_TST_CYCLE is an unsigned 16-bit write only register. It is used to pre-load the CARRIER_CYCLE counter with a specific value. The CARRIER_COUNTER is an 18-bit counter; the two Less Significant Bits will be set to 0 when writing into CHx_TST_CYCLE. ALL_TST_CYCLE operates only on those channels whose CNTTESTMODE bit is High.

Register bit mapping	
Bit	Description
15 to 0	16 MSB bits of the CARRIER_CYCLE counter

CHx_1MS_EPOCH and ALL_1MS_EPOCH

Write Addresses A0, A4, A8, AC, B0, B4 and BC_H

These registers are write-only registers. Their operation is affected by the current channel mode, PRESET or UPDATE. In UPDATE mode, the data being written into these registers is immediately transferred to the 1 ms epoch counter. In PRESET mode however, the data is transferred only after the next TIC. Refer to section 7 of DETAILED OPERATION OF THE GP1020 for more details of the PRESET mode.

Register bit mapping	
Bit	Description
4 to 0	Contains the 1ms Epoch counter value to be loaded. Its valid range is from 0 to 19.
15 to 5	Don't care

CHx_20MS_EPOCH and ALL_20MS_EPOCH

Write Addresses A3, A7, AB, AF, B3, B7, and BF_H

These registers are write-only registers. Their operation is affected by the current channel mode, PRESET or UPDATE. In UPDATE mode, the data being written into 20MS_EPOCH is immediately transferred to the 20 ms epoch counter. In PRESET mode however, the data is transferred only after the next TIC. It is important to load the 20MS_EPOCH register last in the PRESET mode loading sequence because the trailing edge of a write to this register enables the PRESET operation on the next TIC. Refer to section 7 of DETAILED OPERATION OF THE GP1020 for more details of the PRESET mode.

The CHx_20MS_EPOCH contains a test control bit (CNTTESTMODE) which is used to test different counters in the channels. When active this bit selects a 5.7 MHz clock (CLK 2) to drive the 20MS_EPOCH counter and replace the CODECLK signal by the TCK8 input signal, also TCK8 will drive the CODE GENERATOR, the CODE_SLEW and CODE_PHASE counters, and finally, it will allow the CODE GENERATOR to be set to the 1023rd chip position by a write operation to the CHx_ACCUM_RESET location and to write into the CHx_TST_CODE_PHASE and CHx_TST_CYCLE registers.

Register bit mapping	
Bit	Description
15 to 7	Not used
6	CNTTESTMODE: Normal mode when LOW. This bit is set LOW by a master reset and should normally always be programmed LOW. When HIGH, the CODE GENERATOR, the 20MS_EPOCH, CODE_PHASE, CODE_SLEW and CARRIER_CYCLE counters are in test mode.
5 to 0	Contains the 20 ms EPOCH counter value to be loaded. Its valid range is from 0 to 49.

DOWN_COUNT_HI and DOWN_COUNT_LO

Write Addresses C3 and C4_H

These two registers are used to program the Time Mark Generator. Refer to section 11 of DETAILED OPERATION OF THE GP1020 (page 31) for more details of the principle of operation of the Time Mark Generator.

GP1020

DOWN_COUNT_LO is programmed with a 16-bit unsigned integer word, with valid range from 0 to FFFF (HEX).

DOWN_COUNT_HI is programmed with a 5-bit unsigned integer word, with valid range from 0 to 01F (HEX).

The concatenated value of both registers represents the time delay, less 25 nanoseconds, from the next TIC to the Time Mark output signal in units of 50 nanoseconds.

The trailing edge of a write to DOWN_COUNT_LO arms the Time Mark Generator. When the next TIC occurs, the Time Mark Counter is loaded and then decrements until it reaches zero, at which instant the Time Mark is output.

MEAS_STATUS_A Read Addresses 80_H

Register bit mapping	
Bit	Description
0	CH1_NEW_MEAS_DATA
1	CH2_NEW_MEAS_DATA
2	CH3_NEW_MEAS_DATA
3	CH4_NEW_MEAS_DATA
4	CH5_NEW_MEAS_DATA
5	CH6_NEW_MEAS_DATA
6	Not used
7	Not used
8	Not used
9	Not used
10	Not used
11	Not used
12	Not used
13	Not used
14	MARK_FB_ACK
15	RTC_TIC_ACK

REGISTER DESCRIPTION

MEAS_STATUS_A is located at an address contiguous with accumulated data status registers so that it can be read in the same read block operation. The status bits of this register are sampled and latched on the positive edge of every INT OUT or INT IN signal. They can also be sampled and latched on request by performing a write operation to STATUS_LATCH location.

BIT DESCRIPTION

CHx_NEW_MEAS_DATA status bit active HIGH indicates if there is new measurement data available to be read. Each individual bit can be cleared by a write operation with don't care data to CHx_MEAS_RST. This operation releases the overwrite protection. Each bit is also cleared on the trailing edge of a read of the associated CHx_CARR_CYCLE register. If new accumulated data becomes available after status bits have been latched, the overwrite protection is not cleared while reading the CHx_CARR_CYCLE register and the CHx_NEW_MEAS_DATA bit will be set at the next MEAS_STATUS_A. A master reset (hardware or software) and the inhibition of clock phases will also clear this status bit.

RTC_TIC_ACK status bit is set whenever a Real Time Clock interrupt has been received and the 100ms_TIC or 9ms_TIC following the interrupt has occurred. It is reset by a read of RTC_DELAY register or an ALL_MEAS_RST command. RTC_DELAY is overwrite protected by the measurement data protection mechanism.

MARK_FB_ACK status bit is set whenever a Time Mark feedback signal has been received on the selected pin, MARK_FB1, MARK_FB2 or MARK_FB3 or by the selected edge of the TIC OUT signal. It is reset by a read of PROP_DELAY_LO register or a ALL_MEAS_RST command. MARK_FB_ACK is overwrite protected by the measurement data protection mechanism.

RTC_TIC_ACK and MARK_FB_ACK status bits are cleared

by a hardware master reset. A software master reset does not affect the TIME BASE GENERATOR block, where these two flags are generated.

MEAS_STATUS_B Read Address 81_H

Register bit mapping	
Bit	Description
0	CH1_MISSED_MEAS
1	CH2_MISSED_MEAS
2	CH3_MISSED_MEAS
3	CH4_MISSED_MEAS
4	CH5_MISSED_MEAS
5	CH6_MISSED_MEAS
6	Not used
7	Not used
8	CH1_SLEW
9	CH2_SLEW
10	CH3_SLEW
11	CH4_SLEW
12	CH5_SLEW
13	CH6_SLEW
14	Not used
15	Not used

REGISTER DESCRIPTION

MEAS_STATUS_B register is located at an address contiguous with accumulated data status registers so that it can be read in the same read block operation. The status bits of this register are sampled and latched on the positive edge of every INT OUT or INT IN signal. They can also be sampled and latched on request by performing a write operation to STATUS_LATCH location.

BIT DESCRIPTION

CHx_MISSED_MEAS: status bit active HIGH indicating if there has been missed measurement data resulting from a too long delay (> TIC period) before the measurement data specific to this channel was either read or the CHx_NEW_MEAS_DATA bit was cleared. This bit is set on a TIC and latched until either a master reset (hardware or software) or until a write operation to CHx_MEAS_RST

CHx_SLEW: Status indicating if the code phase counter was being slewed at time of TIC sampling. If such is the case, the measurement data is not reliable. This bit is updated at each TIC when the overwrite protection is not active and is reset whenever CHx_MEAS_RST is written into with don't care data or upon a master reset (hardware or software).

All status bits in this register will also be cleared when the clock phase propagation is disabled.

PROP_DELAY_LO and PROP_DELAY_HI

Read Addresses C3 and C4_H

Register bit mapping, PROP_DELAY_LO	
Bit	Description
15 to 0	16 less significant bits of down counter

Register bit mapping, PROP_DELAY_HI	
Bit	Description
4 to 0	5 more significant bits of down counter.
15 to 5	Don't care, held LOW.

PROP_DELAY_LO is a 16-bit register containing the 16 less significant bits of an unsigned integer PROP_DELAY whose value is the number, minus one, of 50 nanosecond intervals completed since the MARK output signal was generated.

PROP_DELAY_HI is a 5-bit register containing the 5 more significant bits of the same integer. This integer comes from the Mark Output programmable down counter and the DOWN_COUNT register as detailed below. If a read access is performed when the programmable down counter is working the data may be not stable. A MARK_FB_ACK status bit should be acknowledged before performing a read access to the PROP_DELAY registers.

The programmable down counter operates as follows:

Time	Counter contents	Remarks
ta	DOWN_COUNT	The counter is loaded by Software with DOWN_COUNT value.
tb		The one second time mark signal is issued and propagates through the output driver. The Down counter wraps round and continues to count down.
tc	PROP_DELAY	When the feedback signal at input pin MARK FB1, MARK FB2, MARK FB3 or Internal TIC signal, as selected by bits 7 to 5 of the TIMER_CNTL register, reaches the down counter, its value is frozen and can be read by the processor, (16 lower bits only)

To get the correct number of 50 ns intervals, 1 should be added to the PROP_DELAY number. For example, if the feedback was so fast that the counter did not have time to count, the PROP_DELAY value will be 1F FFFF_H and by adding 1 the result becomes 00 0000_H.

Other examples of delay counts:

PROP_DELAY value	Real number of 50 ns intervals
00 0000 _H	1
00 0001 _H	2
1F FFFC _H	2,097,150

If there is no feedback coming from the external driver, a time-out function will stop the counter and no MARK_FB_ACK status bit will be asserted. The PROP_DELAY value will be 1F FFFD_H (representing a propagation delay of 104.8575 ms).

The PROP_DELAY value can be used for:

1. Computation of DOWN_COUNT, to compensate for the propagation delay in the output driver circuit if this delay is larger than 50 nanoseconds.
2. As a BITE function, to check that the TIME_MARK output drivers work or to verify the TIC period.

RESET_CNTL Read/Write Address C0_H

Register bit mapping	
Bit	Description
0	MRB (Chip MASTERRESET)
1	CH1_RSTB
2	CH2_RSTB
3	CH3_RSTB
4	CH4_RSTB
5	CH5_RSTB
6	CH6_RSTB
7 to 15	Not used

BIT DESCRIPTION

CHx_RSTB: When active LOW, the reset bit inhibits propagation of the clock phases to the tracking channel and resets the code generator, accumulated and measurement flags, CODE_DCO and CARRIER_DCO accumulators and their associated INCR registers, the I&D accumulators, the code slew counter and finally the code phase counter. This is required for the search algorithm of one satellite signal using many channels in order to start from a known relative code phase on all the channels. However, all of the registers in CHx can be programmed and read as usual. To restart normal operation in the different channels at the same time, the corresponding CHx_RSTB bits should be set to HIGH during the same write operation. All CHx_RSTB are set LOW by a master reset.

MRB: When LOW (software reset), the effect is identical to the hardware MASTERRESET except that the clock generator and the time base generator are not affected. It should be set to HIGH to allow access to the different registers. MRB is set HIGH by a hardware master reset.

RTC_DELAY Read Address C2_H

Register bit mapping	
Bit	Description
15 to 0	Number of clock intervals counted from the occurrence of an RTC interrupt and the next TIC (TIC IN if the external source is selected). Each count represents 2.275 microsecond. The register content is unsigned and the validity range is from 0 to TIC period/2.275 microsecond.

The error in RTC_DELAY is ± 2.275 microsecond as shown in Fig. 16.

RTC_DELAY is latched on a TIC and is overwrite protected by its own measurement data overwrite protection mechanism. The RTC_TIC_ACK status bit of MEAS_STATUS_A register indicates if an RTC interrupt has been received. The RTC_TIC_ACK status bit is cleared by writing to the ALL_MEAS_RST address and also by reading RTC_DELAY register.

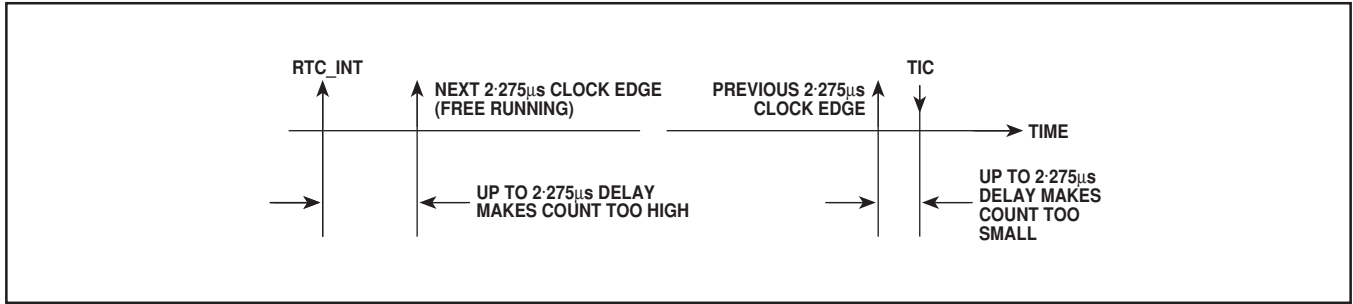

Fig. 16

STAT_CHK_SEL Write Address C5_H

Register bit mapping		
Bit	Description	
	Signal source selection with the following encoding; Bit 3 2 1 0	Selected input port
3 to 0	0 0 0 0	0
	0 0 0 1	1
	0 0 1 0	2
	0 0 1 1	3
	0 1 0 0	4
	0 1 0 1	5
	0 1 1 0	6
	0 1 1 1	7
	1 X 0 0	8
	1 X 0 1	9
	1 X 1 0	Self test signal
	1 X 1 1	Ground
15 to 4	Not used, don't care.	

REGISTER DESCRIPTION

STAT_CHK_SEL can be written into at any time. The SELF TEST SIGNAL is both the sign and magnitude outputs (TSGN and TMAG output pins) of the SELF_TEST_GENERATOR block and are connected internally.

STAT_CHK_SIGN and STAT_CHK_MAG

Read Addresses C5 and C6_H

Register bit mapping	
Bit	Description
13 to 0	Unsigned integer ranging from 0 to 16383 representing the number of sign or magnitude bits sampled during two interrupt time base periods.
15 to 14	Don't care, held LOW.

These registers are overwrite protected. The overwrite protection is released and the NEW_STAT_DATA bit of the ACCUM_STATUS_A is reset on the trailing edge of a read to STAT_CHK_MAG or a write operation to ALL_ACCUM_RESET location. Therefore, STAT_CHK_MAG should be read after STAT_CHK_SIGN.

For the first time the flag NEW_STAT_DATA is set after a master reset, if a write to the STAT_CHK_SEL register has not been performed within two interrupt time base (INT) periods,

non valid data will be latched in STAT_CHK_SIGN and STAT_CHK_MAG registers. For this reason perform a dummy read to STAT_CHK_MAG in order to clear the flag and wait for the next time the flag is set to get valid data.

NOTE: the STAT_CHK_MAG register contains the number of samples having the values +3 or -3, and the STAT_CHK_SIGN register contains the number of positive samples (1 or 3) from the selected input port.

STATUS_LATCH Write Address 80_H

A write to this location with don't care data latches the state of all status bits contained in ACCUM_STATUS_A, ACCUM_STATUS_B, MEAS_STATUS_A and MEAS_STATUS_B. Performing a write to STATUS_LATCH prior to reading the status registers ensures reading of stable status values. The latch takes effect within 200 nanoseconds of the leading edge of the write pulse. The LOW to HIGH transition of the INT signal will also latch the state of the status bit, thus it is not necessary to write to STATUS_LATCH when the status registers are to be read as a response to the INT signal in an interrupt handling routine. The write to STATUS_LATCH is required only when the status registers are read at 'random' times, controlled by the microprocessor. These two mechanisms are mutually exclusive and should not be used in conjunction - if they are both used (a write to STATUS_LATCH after the occurrence of an INT signal) contentions and confusion will result. To avoid this, make sure a read access does not take place at the same time as an interrupt rising edge.

If the INT_MASKB bit in TIMER_CNTL register is not set to HIGH, the interrupt will not latch the status bits in the status registers ACCUM_STATUS_A, ACCUM_STATUS_B, MEAS_STATUS_A and MEAS_STATUS_B but a STATUS_LATCH write access will do so. Also, when a GP1020 is configured as a slave, it should have the INT_SOURCE and the INT_MASKB bits in the TIMER_CNTL register set to HIGH to get the status bits sampled at the same instant in both master and slave GP1020s.

TDATA_DUTY_CYCLE Write Address C8_H

This register is associated with the SELF_TEST_GENERATOR. It allows selection of the duty cycle of the data inversion function.

The time base period is 11 C/A code chips. The value of TDATA_DUTY_CYCLE, valid from 0 to 10, determines the number of chips within the time base period where the data bit modulating the self test signal will be inverted. When the self test signal is fed back in a tracking channel, the inversion causes a slope reversal in the accumulator of the Accumulate and Dump module and prevents the accumulator from saturating over a code epoch when TDATA_DUTY_CYCLE is properly set. This is the same effect as noise on a real satellite signal.

REGISTER OPERATION

This register is a write only register and can be written into at any time. At power up the register is reset, so it will always select the data inversion function. If the bits are all 1 the data inversion

function will never be selected. For standard operation a single 0 is required and all the other bits must be at 1. The position of the 0 in the register allows the duty cycle of the data inversion function to be set as shown below:

Bits	10	9	8	7	6	5	4	3	2	1	0	Description
	0	0	0	0	0	0	0	0	0	0	0	Power up condition, the data inversion function is always selected.
	1	1	1	1	1	1	1	1	1	1	0	The data inversion function is always selected.
	1	1	1	1	1	1	1	1	1	0	1	The data inversion function is selected 10 times in 11.
	1	1	1	1	1	1	1	1	0	1	1	The data inversion function is selected 9 times in 11.
	0	1	1	1	1	1	1	1	1	1	1	The data inversion function is selected 1 time in 11.
	1	1	1	1	1	1	1	1	1	1	1	The data inversion function is never selected.

TIMER_CNTL Write Address C2_H

Register bit mapping		
Bit	Name	Description
0	TIC_PERIOD	When LOW, the TIC period is 175 ns×571,428 = 99-9999ms. When HIGH, the TIC period is 175 ns × 51,948 = 9-0909ms. TIC_PERIOD is set LOW by reset.
1	INT_MASKB	When LOW, the interrupt output signal is disabled, the INT OUT pin is held LOW and the status bits are not sampled by an on-chip or an externally generated interrupt. When HIGH, the interrupt output signal is enabled and the status bits will be sampled by an interrupt. INT_MASK is set LOW by reset.
2	TIC_SOURCE	When LOW, TIC source is internal, when HIGH, TIC source is external (provided by a companion GP1020 through TICIN pin). TIC_SOURCE is set LOW by reset.

Register bit mapping																																							
Bit	Name	Description																																					
3	INT_SOURCE	When LOW, the signal used to latch the state of status bits and the results of the STAT_CHECK block is the positive edge in Intel mode or the negative edge in Motorola mode of the INT signal generated on-chip. When HIGH, the edge of the INT signal provided on INTIN pin of the device by a companion GP1020 is used instead. INT_SOURCE is set LOW by reset.																																					
4	TEST_OP/MARKB	When LOW, the GP1020 MARK output pin will output the time MARK output. When HIGH, the output will be driven by a signal selected by the CH1_DUMP/OSC_CHECK bit (bit 8) of this TIMER_CNTL register. TEST_OP/MARKB is set LOW by reset.																																					
7 to 5		<p>Mark Feedback active edge selection, with the following encoding:</p> <table border="1"> <thead> <tr> <th>Bit</th> <th>Selected function</th> </tr> <tr> <th>7</th> <th>6</th> <th>5</th> </tr> </thead> <tbody> <tr> <td>0</td> <td>0</td> <td>0</td> <td>FB1↑</td> </tr> <tr> <td>0</td> <td>0</td> <td>1</td> <td>FB1↓</td> </tr> <tr> <td>0</td> <td>1</td> <td>0</td> <td>FB2↑</td> </tr> <tr> <td>0</td> <td>1</td> <td>1</td> <td>FB2↓</td> </tr> <tr> <td>1</td> <td>0</td> <td>0</td> <td>FB3↑</td> </tr> <tr> <td>1</td> <td>0</td> <td>1</td> <td>FB3↓</td> </tr> <tr> <td>1</td> <td>1</td> <td>0</td> <td>TICOUT↑</td> </tr> <tr> <td>1</td> <td>1</td> <td>1</td> <td>TICOUT↓</td> </tr> </tbody> </table> <p>The FBx↑ (rising edge) and FBx↓ (falling edge) signal edges are used to calculate the pulse width of the Mark Feedback signal. This calculation allows monitoring of the pulse width and verification that the result is in accordance with the 1 ms ± 0.01 ms specification. The TIC OUT signal is also available as feedback for test purposes. Bits 7 to 5 are set LOW by reset.</p>	Bit	Selected function	7	6	5	0	0	0	FB1↑	0	0	1	FB1↓	0	1	0	FB2↑	0	1	1	FB2↓	1	0	0	FB3↑	1	0	1	FB3↓	1	1	0	TICOUT↑	1	1	1	TICOUT↓
Bit	Selected function																																						
7	6	5																																					
0	0	0	FB1↑																																				
0	0	1	FB1↓																																				
0	1	0	FB2↑																																				
0	1	1	FB2↓																																				
1	0	0	FB3↑																																				
1	0	1	FB3↓																																				
1	1	0	TICOUT↑																																				
1	1	1	TICOUT↓																																				

Register bit mapping		
Bit	Name	Description
8	CH1_DUMP/OSC_CHECK	When LOW the GP1020 MARK output pin will output a square wave with a period of 4.55 microseconds. (40MHz/182). Because this clock is derived from the TCXO, its stability and accuracy is representative of the TCXO stability and accuracy. When HIGH, the GP1020 MARK output pin will output a square-wave changing its level at each DUMP event in channel 1. These features are used for test purposes during ATP of the GPS sensor unit and the TEST_OP/MARK bit (bit 4) must be set to HIGH to get either of these two test outputs. CH1_DUMP/OSC_CHECK is set LOW by reset.
12 to 9		Interrupt time base selection with the encoding given in the following table.

Bit	12	11	10	9	Selected interrupt timebase period (μ s)	High time (μ s)	Low time (μ s)
	0	0	X	X	505.050	252.525	252.525
	0	1	0	0	420.875	84.175	336.700
	0	1	0	1	505.050	252.525	252.525
	0	1	1	0	589.225	336.700	252.525
	0	1	1	1	673.400	336.700	336.700
	1	0	0	0	757.575	420.875	336.700
	1	0	0	1	841.750	420.875	420.875
	1	0	1	0	925.925	505.050	420.875
	1	0	1	1	1010.100	84.175	925.925
	1	1	0	0	1094.275	168.350	925.925
	1	1	0	1	1178.450	84.175	1094.275
	1	1	1	0	1262.625	168.350	1094.275
	1	1	1	1	1346.800	420.875	925.925
Bits 12 to 9 are set LOW by reset.							

DETAILED OPERATION OF THE GP1020

1. MASTER RESET - Hardware or Software.

At Master Reset, all registers, accumulators and counters are cleared except CHx_CNTL. In particular, this implies the following initial states:

- All CHx_RSTB bits of the RESET_CNTL register are cleared. Thus all tracking channel clock phases are disabled. Programming registers can take place either before or after releasing the CHx_RSTB bits.
- All the tracking channels are in UPDATE mode, the satellite code selected is GPS PRN No. 17 and the EARLY code is selected on the dithering arm. All CHx_CNTL registers are in MODE 1.
- The TIC generator will be free running at start-up with a 100ms TIC period setting. The INT_MASKB bit of the TIMER_CNTL register is LOW, therefore the INT_OUT signal will be disabled and the output pin held LOW. The interrupt time base is set to 505.05µs.
- The BITECNTL bit of the BITE register is reset LOW (inactive state). The associated BITECNTL output pin is also LOW.
- The data bus is forced into input mode to avoid contention at power up.

2. SEARCH OPERATION at Power up, after a power glitch, or after losing satellite signals.

REGISTER INITIALISATION

For each channel, the proper GPS or GLONASS signal source has to be selected by writing the proper code into CHx_SIG_SEL registers. The contents of these registers can be changed at any time during the operation to change the signal sources for any channels.

At power up, all CHx_RSTB bits of the RST_CNTL register are in the reset LOW state. As stated above, in that state, all tracking channel control registers can be programmed.

When it is required to perform a SEARCH for one satellite with more than one channel, these channels are first reset if not already in that state, with the corresponding CHx_RSTB bits, then the control registers are programmed. In particular, each CODE_SLEW register is programmed with a different value. Then, the CHx_RSTB bits are released, causing the channels to start operating at the same time with the same code phase. One millisecond later, all channels will get the same accumulated data and will be slewed with the pre-programmed values and will continue with a known relative code phase difference. Note that every time CHx_RSTB is set LOW, the code generator is reset.

The following additional initialisation operations have to be performed. The block write addresses can be used whenever appropriate.

CARRIER DCO PROGRAMMING

The CARR_INCR_HI and the CARR_INCR_LO registers are programmed in sequence with the relevant data according to the estimated DOPPLER shift for the frequency bin being looked at. The programming is effective as soon as the write operation to CARR_INCR_LO is completed (In fact, a small delay of 175 ns maximum will occur to allow synchronisation of the processor write operation to the chip operation). If the content of CARR_INCR_HI does not need to be modified, it is not necessary to write into it. It is always necessary to write into CARR_INCR_LO in order for the programming to be effective. Note that, typically, the search algorithm would dwell on a given frequency bin and perform a search over all code phases. Then it would repeat the process for the next frequency bin.

CODE DCO PROGRAMMING

The tracking channel being in UPDATE mode, the PRESET_PHASE register does not need to be programmed. The CODE_INCR_HI and the CODE_INCR_LO registers are

programmed in sequence with the relevant data according to the estimated DOPPLER shift. Given that the CHx_RSTB bit of the RESET_CNTL register is inactive, the programming is effective as soon as the write operation to CODE_INCR_LO is completed. If the content of CODE_INCR_HI does not need to be modified, it is not necessary to write into it. It is always necessary to write into CODE_INCR_LO in order for the programming to be effective.

CODE GENERATOR PROGRAMMING

1. Select in CHx_CNTL register the type of code to be used in the dithering arm of the correlator; normally, for a search operation, either an early or a late code is selected. The PRESET/UPDB bit will be set LOW, for example, in UPDATE mode by master reset.
2. Select in CHx_CNTL register the code to be generated among the 45 possible C/A codes or the unique GLONASS code. (Actually, all possible code combinations are programmable even those not used by the GPS constellation and some GLONASS-like codes are also available.) The selected code is applicable to both the prompt and the dithering arm.
3. Program each tracking channel CODE_SLEW register with the desired code phase. The slew operation will become effective at the first dump e.g. about 1 ms after CHx_RSTB release. The first dump will generate don't care accumulated data and will set the associated CHx_NEW_ACCUM_DATA status bit. The second and the following dumps will generate useful data.
4. Release the relevant CHx_RSTB bits of the RESET_CNTL register in order to start operation of the tracking channels. When channels of more than one GP1020 are being used to search for the same code, consecutive write operations to each chip's RESET_CNTL register should ensure a startup with reasonably well known relative code phases between the two chips.

Whenever the code clock is being inhibited (to slew the code phase), the Accumulate & Dump module is held reset. It will start to accumulate correlation results only after the slew operation is completed.

3. READING the ACCUMULATED Data

Every time a DUMP occurs, the corresponding CHx_NEW_ACCUM_DATA status bit is set in the ACCUM_STATUS_A register. All In-phase and Quad-phase registers together with ACCUM_STATUS_A and ACCUM_STATUS_B registers are mapped in consecutive addresses so that they can be block-read after every timebase interrupt. Alternatively, a polling technique can be used by periodically reading the ACCUM_STATUS_A register to find if an interrupt or a write into STATUS_LATCH has been performed.

The data contained in the IN_PHASE and QUAD_PHASE registers of the prompt and dithering arms will be protected from an overwrite due to consecutive DUMP events. The protection mechanism is released on the trailing edge of a read operation of the Q_PROMPT register. Thus the order of reading I_DITH, Q_DITH and I_PROMPT is optional but Q_PROMPT must always be read last to ensure coherence of the data set and to release the overwrite protection mechanism.

The CHx_MISSED_ACCUM bit of the ACCUM_STATUS_B register indicates new accumulated data has been missed because of a too long response time for reading the accumulated data. This status bit, when set, is latched until it is cleared by a write operation to CHx_ACCUM_RESET or by a master reset or by CHx_RSTB set to LOW.

4. SEARCH on other CODE PHASES

When it is desired to correlate on the next code phase, the CODE_SLEW has to be programmed with a value of 2 (in units

of half code chips). The slew will be effective on the next dump. Thus this dump will generate don't care accumulated data and as a minimum, the Q_PROMPT register will have to be read to release the overwrite protection mechanism.

Note that it is only possible to delay the phase of the code. It cannot be advanced.

5. DATA BIT SYNCHRONISATION Related Operations

When the right code phase is found, the carrier loop is closed. The CARR_INCR_HI and CARR_INCR_LO registers can be reprogrammed at any time to close the feedback loop and resume code tracking.

The Data Bit Sync algorithm should find the data bit transition instant. The processor calculates the present one millisecond epoch and programs this value into the 1MS_EPOCH register. The effect is immediate.

After each DUMP, the epoch counter value can be read within 1ms and preferably at the same time as the integrate and dump registers. This provides a means of verifying that the epoch counters are indeed properly programmed. Programming the epoch counter in the 500µs period following a valid CHx_NEW_ACCUM_DATA should ensure that the programming becomes effective before the next DUMP.

Alternatively, the EPOCH registers can be left free-running and the delta-epoch can be added by the software each time it reads the EPOCH registers. However, the dithering between early and late code will be controlled by the actual contents of the EPOCH registers, which will not necessarily be in phase with data bit boundaries.

6. READING the MEASUREMENT Data

At every occurrence of a TIC, the measurement data is latched in measurement data registers. The TIC does not generate any interrupt signal, however, it does set the CHx_NEW_MEAS_DATA status bits of the MEAS_STATUS_A register. This register is normally always read while collecting accumulated data once every 505.05 microseconds (The INT_OUT signal rate). The software tests the CHx_NEW_MEAS_DATA status bits to determine if new measurement data is available to be read. For each channel, the last measurement data register to be read must be CHx_CARR_CYCLE because the trailing edge of this read releases the overwrite protection mechanism and clears the corresponding CHx_NEW_MEAS_DATA bit. The software must also read the MEAS_STATUS_B register to determine if there was any missed measurement data or if phase and epoch counters were being slewed during the last TIC period, indicating invalid measurement data for the affected channel.

7. The PRESET Mode

Each tracking channel can be individually programmed to operate either in UPDATE or PRESET mode. A given channel is programmed in PRESET mode by writing a HIGH into the PRESET/UPDB bit of the CHx_CNTL register.

The sequence of operations is as follows:

1. Write into CHx_CNTL to select the PRESET mode together with the appropriate code, code format on the dithering arm, etc. Since the PRESET mode is selected, the new selected code and code format will be effective on the next TIC.
2. Between the instant at which the PRESET mode is selected and the next TIC, the tracking channel will continue to operate normally, that is, it will provide accumulated data for the signal being tracked.
3. The INCRement registers of the CODE and CARRIER DCO'S have to be loaded with the appropriate frequencies for the new signal to be tracked either immediately or only after the TIC has occurred if it is desired not to disturb the tracking in effect.

4. Load the following PRESET registers:

PRESET_PHASE: Will set the code DCO phase.
 CODE_SLEW: Will set the code phase.
 1MS_EPOCH: Will set the 1 ms epoch.
 20MS_EPOCH: Will set the 20 ms epoch.

It is important to have the PRESET mode selected prior to programming the CODE_SLEW and the EPOCH registers in order to have these new values effective on the next TIC as opposed to immediately if they were programmed under UPDATE mode. The PRESET_PHASE register can be programmed either before or after selecting the UPDATE mode. In PRESET mode the value to program in the CODE_SLEW register represents the delay between the TIC and the first code chip.

To ensure correct PRESET of EPOCH counters, the loading of PRESET registers has to be completed prior to the TIC relative to which the PRESET values are computed. Thus the operation has to take place within a TIC window.

It is important to load the 20MS_EPOCH register last in the loading sequence. The trailing edge of a write to this register enables the PRESET operation on the next TIC.

5. After the PRESET operation has taken place on a TIC, the PRESET/UPDB bit of the CNTL register is reset and the channel goes back to UPDATE mode. It is possible that the code phase has to be slewed so the CODE_SLEW register when loaded will then cause a slew to start on the next DUMP.

On the TIC, the measurement data saved for the signal being tracked so far will be valid. The measurement data registers (or at least CHx_CARRIER_CYCLE register) must either be read or a write operation to CHx_MEAS_RESET must be made in order to clear the measurement status bits and allow measurement data acquisition on the next TIC for the new signal to be tracked under PRESET mode.

8. The TIC GENERATOR and the Interrupt Time Base

The interrupt time base consists of a free-running counter providing a pulse of constant period on a GP1020 output pin. The frequency uncertainty on this time base will be identical to the system oscillator drift. The interrupt time base shares some dividers with the TIC generator. The period of this time base is $175\text{ns} \times 2886 = 505.05\mu\text{s}$ at power up, but may be changed by programming TIMER_CNTL register, and is always an exact sub-multiple of the TIC time base. Every 198th (or 18th) interrupt pulse at default rate will occur at the same time as a 100ms (or 9.0909ms) TIC, not taking into account propagation delays. Either INT_IN or INT_OUT (as controlled by the INT_SOURCE bit of the TIMER_CNTL register) is used to sample and latch the status bits and statistics on incoming sign and magnitude bits.

The interrupt is maskable. The INT_MASKB bit of the TIMER_CNTL register when set LOW forces the logic level on the output pin to LOW. A master reset will set this bit LOW.

9. SIGNAL PATH DELAY Introduced by Hardware Signal Processing

The signal path delay has two components as follows:

$$D_t = \text{Total path delay} = D_a + D_d$$

D_a = Analogue path delay; varies with temperature and component tolerances.

D_d = Digital path delay; constant if oscillator drift variations are neglected.

For GPS signals, $D_d = 125\text{ns}$. This delay is the time from the sampling edge of the SIGN and MAG bits in the GP1010 (SAMP_CLK) to the performance of the correlation in the GP1020 on these same SIGN and MAG bits (100ns) plus the delay between the correlation and the TIC clock phases in the master GP1020 (25ns).

10. Short Glitch Recovery

Refer to the block diagram shown in Fig. 17 for the following discussion.

It is assumed that the RTC selected provides an interrupt output signal which occurs periodically, every 100ms or every second. The interrupt is sent to both the GP1020 and the processor system. Within the GP1020, the interrupt is connected to the RTC_INT input pin of the GP1020. Its edge enables the RTC_DELAY counter. This counter is clocked by a signal with a period of 2.275µs and increments until the next TIC. The TIC causes the value of RTC_DELAY to be latched in order to be read with the measurement data.

If data bit synchronisation cannot be achieved on a given channel, but proper code and carrier lock are obtained, the software should jump to the data bit synchronisation algorithm. If lock is not obtained, then the software should jump to the search algorithm. Given the magnitude of error terms (summed) and the worst case error allowed in order to keep data bit synchronisation, it is possible to calculate the length of the longest permitted power glitch. See Fig. 20.

11. TIME MARK Generator

The Time Mark generator is designed to provide a one second Time Mark output signal which can be synchronised with a given time

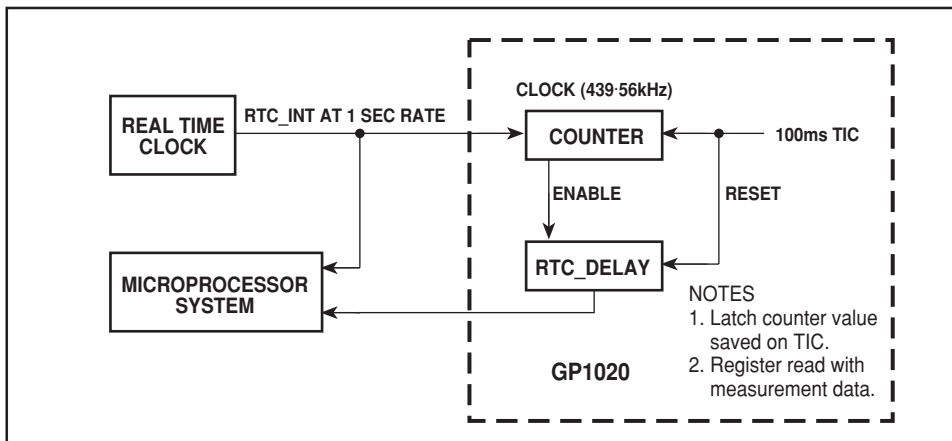

Fig. 17 RTC block diagram

When the processor receives the RTC interrupt, it reads the RTC time. Alternatively, RTC_TIC may not be routed to the processor, but instead, every time the RTC_TIC_ACK status bit of MEAS_STATUS_B is set in the GP1020, the software reads the RTC time. With this information, together with the contents of RTC_DELAY, the software is able to determine first the delay between the RTC and the system clock and secondly, with consecutive readings, the RTC drift can be evaluated. These two pieces of

base, such as the receiver time base, the GPS time or UTC. The Time Mark is generated after a certain programmable delay relative to the TIC.

The architecture chosen (see Fig. 19) involves minimal hardware being clocked at a high rate and so gives low power consumption.

As an example, to synchronise TIME MARK to UTC, the software could have the following sequence of operations (see Fig. 21):

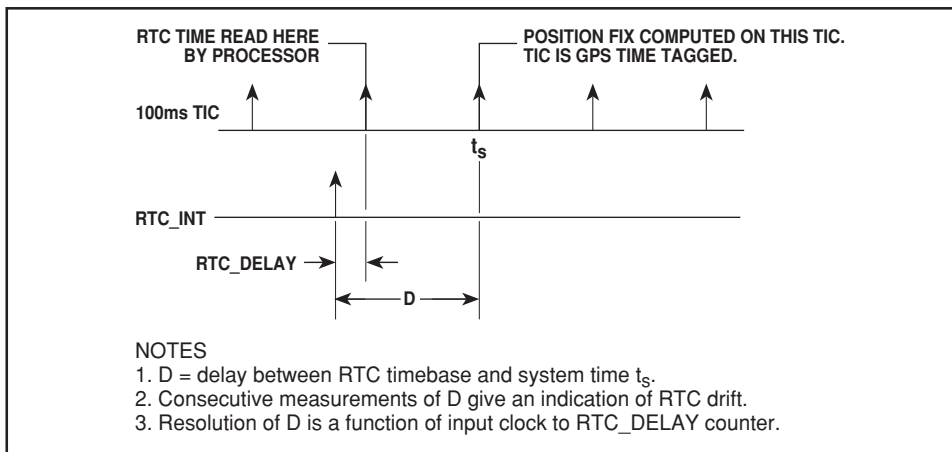

Fig. 18 RTC timing diagram

information are stored in non-volatile RAM every time they are calculated. After occurrence of a power glitch, the 100ms_TIC timebase restarts free running but with an arbitrary phase relationship with respect to the TICs before the power glitch. The RTC interrupt process occurs again as described above and it is possible to relate the new system TIC time relative to the previous. Ideally, this process is precise enough such that the data bit sync is not lost and all the channel control registers can be reprogrammed with proper values. Once the timing relationship is known, the PRESET mode can be used to resume tracking of the signals.

1. Acquire measurement data at time t_0 (on an arbitrary TIC)
2. Solve for UTC at measurement instant $UTC(t_0)$. Note that the solution can only be accurate to within the hardware propagation delays in the receiver, typically a few microseconds, unless these delays are calibrated and UTC solution is corrected accordingly.
3. Compute on which 100ms TIC, t_m , to take the next sample of measurement data such that:

$$UTC \text{ TIME MARK} - t_m = \delta_1 + \delta_2$$

GP1020

Where UTCTIME MARK = Desired time mark synchronised to a UTC second.

$$\delta_1 = k \times (\text{time between TICS}),$$

where $k = \text{INTEGER}$ and $\delta_1 > \text{Nav solution computation delay}$.

$$\delta_2 = \text{time offset (with 50 ns resolution) between time mark and 100ms_TIC labelled } t_r$$

$$\delta_2 < (\text{time between TICS})$$

4. ● Acquire measurement data at t_m
- Compute Nav solution at t_m
- Propagate Nav solution at UTC
- Given the oscillator drift, the delay of 25 ns added by TIME_MARK_GEN block and the calibrated propagation delay, compute DOWN_COUNT, the value to program into the programmable down counter to delay the time mark by δ_2 .
5. Program down counter with DOWN_COUNT before the occurrence of t_r .
6. Output ARINC Data within 200ms after t_r (following ARINC 743)
7. Locate $t_m + 1$ and go back to step 4.

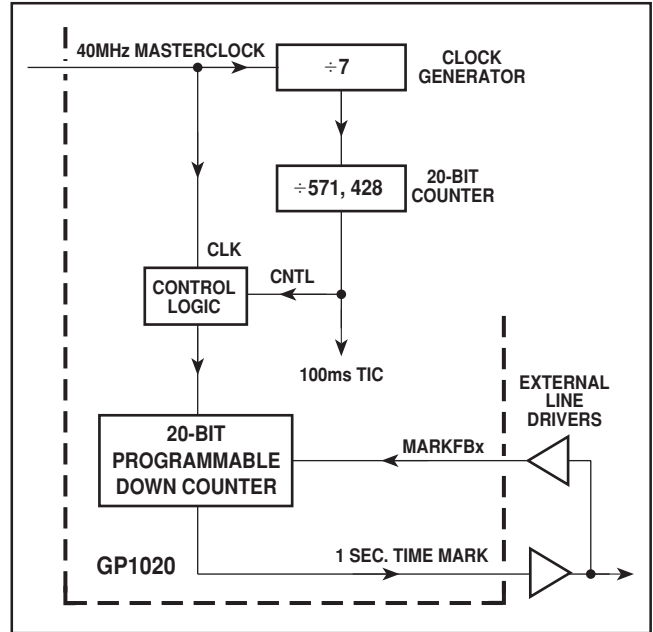

Fig. 19 Block diagram of TIME MARK generator

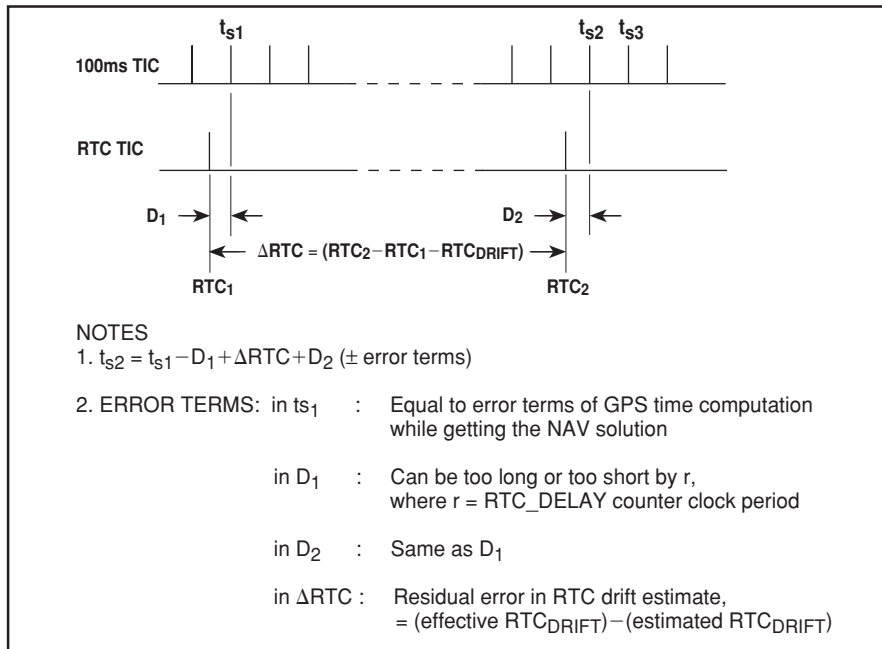

Fig. 20 Timing diagram of a short glitch

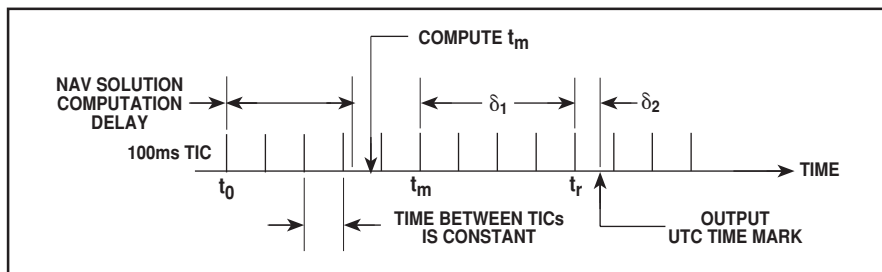

Fig. 21 TIME MARK timing diagram

UTC ERROR BUDGET

The following error budget is associated with the generation of the Time Mark:

Total Error =

- TDOP+Clock Resolution+Oscillator Drift Residual Error.
- + Computation induced Error.
- + Time mark transfer delay through Drivers/cables.
- + Propagation delay in hardware, from antenna to correlator to measurement data sampler, where typical values are:

1. **TDOP:** estimated at 177ns with S/A ON (2 σ number)
2. **Clock Resolution:** 50ns (in 21 bit programmable down counter).
3. **Oscillator Drift Residual Error:**

- (a) Due to temperature change on TCXO since last oscillator drift computation: about 50ns, computed with the following assumptions:

- (i) TCXO max slope is ± 1 ppm/ $^{\circ}$ C
- (ii) Temperature max variation is 5 $^{\circ}$ C/minute
- (iii) The oscillator drift is computed every second and is at most one second old at UTC time mark.

For example:

$$1\text{ppm}/^{\circ}\text{C} \times 5^{\circ}\text{C}/\text{min} \times 1\text{sec} = 83\text{ns for a temperature step change or } 41.5\text{ ns (rounded to 50ns) for a linear ramp}$$

- (b) Due to bias in drift estimation about 50ns max (rough guess)

TOTAL oscillator drift error = (a) + (b) \approx 100ns.

4. Computation induced error: It is assumed that enough significant bits are retained such that this error approximates zero.

5. TIME MARK transfer delay through drivers/cables: This will be calibrated and compensated for up to the GPS receiver's output using the feedback to the down counter. There will be a residual error due to:

- (a) Clock resolution = 50ns
- (b) Feedback delay calibration = 25ns (estimated)

6. Propagation delays in the hardware: These are estimated to be in the range of a few microseconds and are therefore the major contributor to the TIME MARK synchronisation error. An estimate could be included in the software to improve total accuracy when the total hardware design is complete.

$$\text{TOTAL} = 177\text{ns} + 50\text{ns} + 100\text{ns} + 0 + 75\text{ns} + \text{hardware delays}$$

$$\text{TOTAL} = 402\text{ns} + \text{hardware delays.}$$

12. INTEGRATED CARRIER PHASE measurement

The GP1020 tracking channel hardware allows measurement of integrated carrier phase through CHx_CARR_CYCLE and CHx_CARR_DCO_PHASE registers. These two registers are part of the measurement data sampled every TIC. The first one contains the 16 more significant bits of the number of full cycles elapsed and the second one contains the two remaining less significant bits plus the cycle fraction (phase). Fig. 22 shows how to add consecutive readings of these registers over several TICs in order to get a consistent integrated carrier phase.

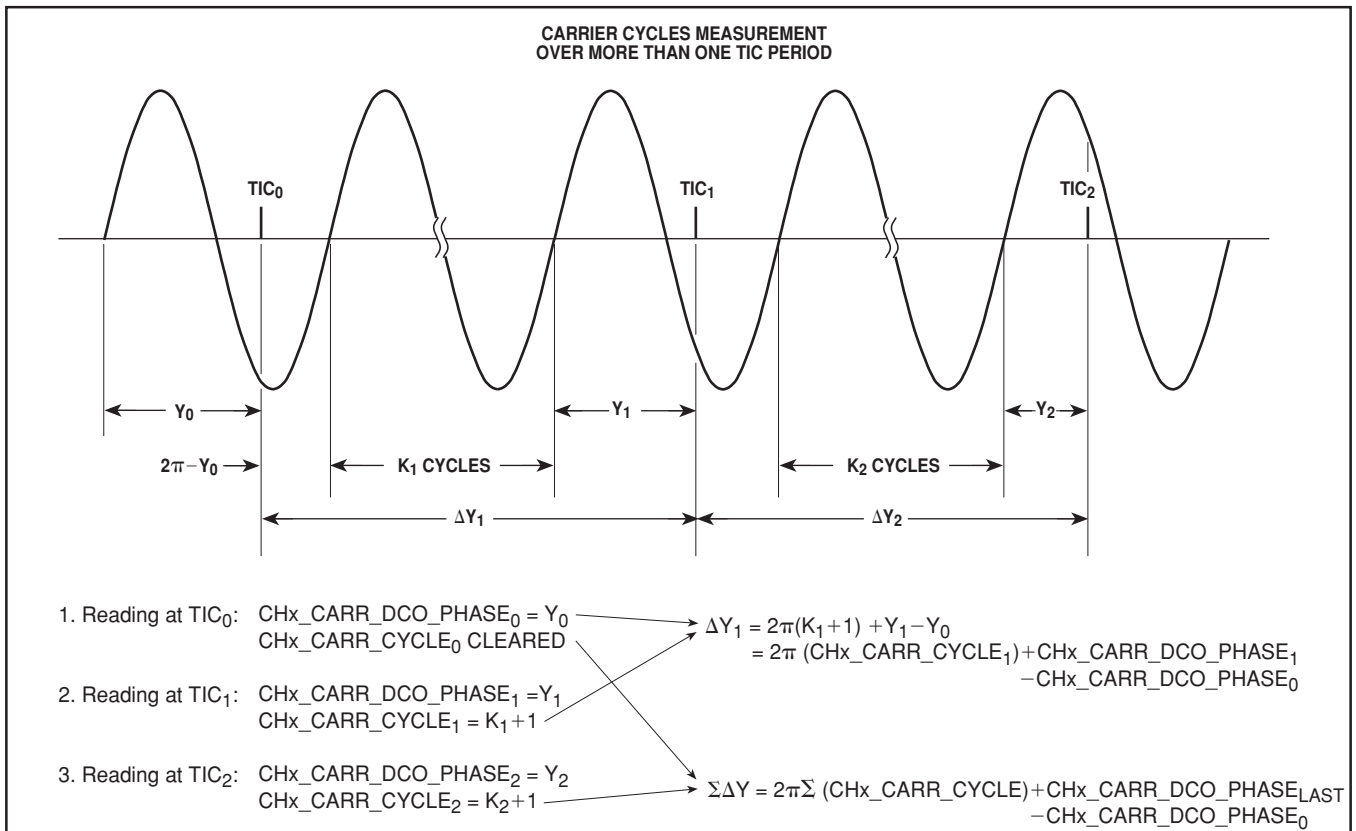

Fig. 22 Integrated carrier phase measurement

13. BUILT-IN TEST Functions

A. CHIP LEVEL Built-in Test Functions

SELF_TEST_GENERATOR

The GP1020 provides an on-chip self-test pattern generator which is switched on under software control by setting SELF_TEST_EN bit of the BITE register. It uses tracking channel 1 or 2 according to the setting of SELF_TEST_SOURCE bit of the BITE register to generate SIGN and MAGNITUDE -like signals which can be fed back to any or all other channels by selecting the self test signal source in CHx_SIG_SEL. The self-test signal has a fixed data bit pattern of alternating one and zero every 20 milliseconds, the first bit being LOW. It has a fixed noise pattern which corresponds to particular In-phase and Quad-phase accumulated values. The C/A code and the Doppler shift can be varied by programming the relevant registers of the channel which has been selected by SELF_TEST_SOURCE. The standard software can then be used to acquire and track the self-test signal but it should take into account the fact that this self-test signal is not a real GPS signal.

The SELF_TEST_GENERATOR output signal can also be wrapped around externally by connecting the TSIGN and TMAG output pins to a GPS or GLONASS input port. Normally, the test source and tested channels will have the same DCO settings.

The next table contains the truth table of the weight converter used in the SELF_TEST_GENERATOR :

CARRIER_DCO bits (MSB-LSB)	MAG	SIGN
01011	1	MSB
011xx	1	MSB
100xx	1	MSB
10100	1	MSB
All other combinations	0	MSB

The design of the weight converter will drive a HIGH on the SIGN bit for 50% of the time and on the MAG bit for 31% of the time.

Examples 1 and 2 show the results of the five first accumulations of the accumulated data for two different settings of the SELF_TEST_GENERATOR and the channels. Because the channels had been started at the same time, they are practically in phase with the incoming data (Sign and Mag outputs of the SELF_TEST_GENERATOR).

Example 1:

Register settings	Value (Hex)	Comments
BITE	0020	STG on, CH1 as source
TDATA_DUTY_CYCLE	0000	No noise (will cause an overflow condition in Q_PROMPT register if signals are in phase)
CHx_SIG_SEL	000A	Signal from the STG
CHx_CODE_INCR_HI	016E	
CHx_CODE_INCR_LO	A4A8	
CHx_CARR_INCR_HI	01F5	
CHx_CARR_INCR_LO	C28F	
CHx_CNTL	0225	
RESET_CNTL	007F	Start all channels at the same time

Results	First dump	Second dump	Third dump	Fourth dump	Fifth dump
CHx_I_DITH	0388	0318	016C	04CC	02AC
CHx_Q_DITH	3D28	3D98	3C34	3D78	3FE4
CHx_I_PROMPT	0A30	093C	0930	08F8	0978
CHx_Q_PROMPT	7FFC	7FFC	7FFC	7FFC	7FFC

Example 2:

Register settings	Value (Hex)	Comments
BITE	0020	STG on, CH1 as source
TDATA_DUTY_CYCLE	07F7	Invert the data 8 times in 11
CHx_SIG_SEL	000A	Signal from the STG
CHx_CODE_INCR_HI	016E	
CHx_CODE_INCR_LO	A4A8	
CHx_CARR_INCR_HI	01F5	
CHx_CARR_INCR_LO	B1B3	
CHx_CNTL	0315	
RESET_CNTL	007F	Start all channels at the same time

Results	First dump	Second dump	Third dump	Fourth dump	Fifth dump
CHx_I_DITH	2230	1EB8	2170	2030	1F00
CHx_Q_DITH	0598	0568	0374	078C	03CC
CHx_I_PROMPT	F8F4	0078	03E8	FF08	0590
CHx_Q_PROMPT	46D8	4798	4914	47B8	46D4

ADD_DAT_TST REGISTER

The ADD_DAT_TST register allows the software and the ATE to verify the functionality of the data and address busses. For full details see ADD_DAT_TST section of DETAILED DESCRIPTION OF REGISTERS.

B. SYSTEM-LEVEL Built-in Test Functions

GP1010 BITE interface:

The GP1020 BITE CNTL discrete output is provided to drive the corresponding discrete input pin of the GP1010. When active, this control unlocks the PLL and switches off the GP1010 front-end amplifiers. As a result, the GP1020 should read an unlocked status at its PLL LOCK discrete input.

The GP1020 includes Sign and Magnitude statistics checker circuit.

GLONASS IC BITE interface:

Uses the same BITE CNTL discrete output to put the GLONASS IC into test mode and one GP1020 discrete input pin, GLONASSBIT, for GLONASS IC go/nogo status.

TIME MARK :

Three MARK FEEDBACK input pins, selected by bits 7 to 5 of TIMER_CNTL, are provided for testing the signal outputs of TIME MARK line drivers.

Also, software selectable control bits (TIMER_CNTL bits 4 and 8) allow multiplexing of the normal 1 second period TIME MARK with one of two test signals, either 40MHz/91 = 439.5604KHz intended for oscillator drift measurement or CH1_DUMP for system fault-finding purposes.

14. CHIP MANUFACTURING-TEST Functions

The GP1020 design incorporates a series of features to increase (a) the observability of internal nodes when working in the application and (b) the observability and the controllability of the circuit during chip-level testing during manufacture. The following presents a summary of the chip test functions:

TEST REGISTERS

A number of registers have been added to improve the testability of the chip. They are not required for normal operation : CHx_TST_CODE_PHASE, CHx_TST_CYCLE and CHx_TST_CODE_SLEW.

Scan Loops and Internal Node Real-Time Observability

A number of registers are not connected to the data bus in any way. These registers have two modes of operation: The normal mode and the SCANLOOP mode in which the flip flops are cascaded to form a shift register. There is one such scan loop per channel.

Fig. 23 shows a block diagram of the Chip test functions. TDI1 (Test Data In) is a serial input common to all scan loop shift registers. Each scan loop has a separate data O/P pin TDO (1:7) (Test Data Out).

The control signal TSCAN (Test Scan) determines whether the registers operate in normal mode (TSCAN LOW) or in scan loop mode (TSCAN HIGH).

The Control Signal TCKS (Test Clock Select), when HIGH, selects the 7 test clocks TCK(1:7) as a replacement for the seven clock phases provided by the clock generator in normal mode. This is intended for use only in the device factory and not in normal operational use. TMS1 and TMS2 are Test Mode Select control pins. Their function is detailed in the following table:

TMS2	TMS1	
LOW	LOW	Normal mode: SIGN (2:8) and MAG (2:9) configured as inputs. TDO (1:7) held LOW. TCK(1:7) configured as inputs. SIGN (9) is always used as a normal input.
LOW	HIGH	Scan Loop mode: SIGN (2:8) and MAG (2:9) configured as inputs. TDO (1:7) output serial scan data. TCK (1:7) configured as inputs.
HIGH	X	Channel 1 observability mode: SIGN (2:8), MAG (2:9) and TCK (1:7) configured as outputs and together with TDO (1:7) allow real-time observability of internal nodes of channel 1 as listed below. The internal TIC signal and the signal latching the status bits are also available on TDO4 and TDO7 pins.

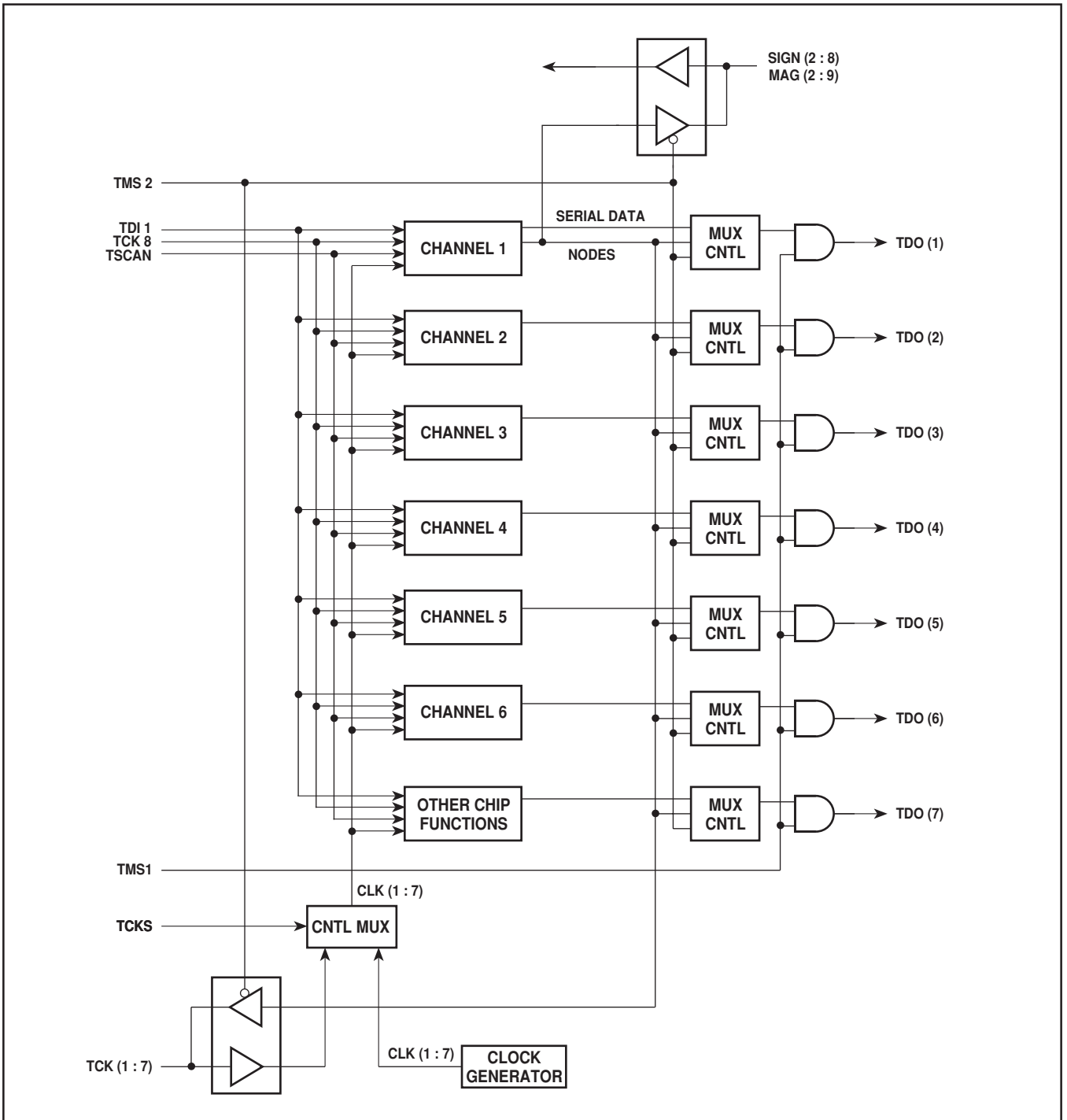

Fig. 23 Chip test functions

TABLE OF ACCESSIBLE CHANNEL INTERNAL NODES

CNTL PIN: TMS1: CNTL PIN: SIGN9	LOW LOW	HIGH LOW	LOW HIGH	LOW HIGH
O/P pin	IN PHASE I & Q ACCUMULATOR ARM			
	Prompt	Dithering	Prompt	Dithering
SIGN 2	bit 13	13	12	12
MAG 2	bit 11	11	5	5
SIGN 3	bit 10	10	4	4
MAG 3	bit 9	9	3	3
SIGN4	bit 8	8	2	2
MAG 4	bit 7	7	1	1
SIGN 5	bit 6	6	0	0
	QUAD-PHASE I & Q ACCUMULATOR ARM			
	Prompt	Dithering	Prompt	Dithering
MAG 5	bit 13	13	12	12
SIGN 6	bit 11	11	5	5
MAG 6	bit 10	10	4	4
SIGN 7	bit 9	9	3	3
MAG 7	bit 8	8	2	2
SIGN 8	bit 7	7	1	1
MAG 8	bit 6	6	0	0
MAG 9	Dump	Dump	Dump	Dump
	MIX_CORREL output			
	In Phase ARM		Quad Phase ARM	
	Prompt	Dithering	Prompt	Dithering
	TCK3	bit 0	0	0
TCK4	bit 1	1	1	1
TCK5	bit 2	2	2	2
TCK6	bit 3	3	3	3
CNTL PIN: TMS1: CNTL PIN: SIGN9	LOW X		HIGH X	
TDO1	CodeCLK		Code CLK	
TDO2	Prompt C/A code		Dithering C/A code	
TDO3	Preset load		CARR DCO O/P bit 25	
TDO4	TIC		CARR DCO O/P bit 26	
TDO5	CARR DCO O/P bit 27		CARR DCO O/P bit 27	
TDO6	1ms epoch carry		1ms epoch carry	
TDO7	STATUS latch control		STATUS latch control	
CNTL PIN: TMS1: CNTL PIN: SIGN9	X X			
TCK1	Sampled SIGN			
TCK2	Sampled MAG			
TCK7	RESCODEGEN			

GP1020

15. BOUNDARY SCAN LOOP

A boundary scan loop is implemented to allow the ATE to verify the connections of the chip at board level. The following pins are not included in Boundary Scan Loop :

TDI1	100/219kHz	SAMPCLK	MASTERCLK	BIAS
PLLLOCKIN	SLAVECLK	TCK(1:8)	MARK	<u>RTCINT</u>
MARKFB1	MARKFB2	MARKFB3	NANDA	NANDB
NANDOP				

The TAP controller has all functions necessary to be compatible with the JTAG standard (IEEE 1149.1-1990) with a few exceptions:

All bidirectional pins are in input mode when the TRST signal is inactive (HIGH) so the chip cannot run freely when in bypass mode.

- The Capture-IR state loads the instruction 000 instead of x01.
- The pins TMS, TCK and TRST do not have pull-up resistors.
- This is the order of the pins in the loop (column by column):

A7	INTOUT*	MAG9	D2	D15
A8	SIGN2	SIGN9	D3	ALE
MASTER/SLAVE	MAG3	MAG1	D4	A1
TCKS	SIGN3	SIGN1	D5	A2
MASTERRESET	MAG4	MAG0	D6	A3
MOT/INTEL	SIGN4	SIGN0	D7	A4
CS	MAG5	CLKSEL	WPROG	A5
WEN	SIGN5	BITECNTL*	D8	A6
RW	MAG6	GLONASSBIT	D9	TSCAN
TMS2	SIGN6	INTIN	D10	
TMS1	MAG7	TICIN	D11	
TMAG*	SIGN7	TICOUT*	D12	
TSIGN*	MAG8	D0	D13	
MAG2	SIGN8	D1	D14	

NOTE: An asterisk in the above list indicates an output pin.

APPLICATION NOTES**PCB LAYOUT CONSIDERATIONS**

The GP1020 is a fast CMOS device so, although clock rates are low, the edge speeds can be very high. The board layout must, therefore, handle these edges on both output signals and on power supply current.

SIMPLIFIED SYSTEM

It is not always necessary to use all of the features of the GP1020 to make a good GPS receiver. The following pin connections show the minimum requirement and are given as a guide only.

Unused inputs must be tied to V_{SS} or V_{DD} and not left floating. Failure to observe this may result in malfunction or damage to the device.

Pin No.	Signal name	Description	Connection
1 and 2	A7, A8	Address bus	To microprocessor
3	MASTER/SLAVE	Master or Slave mode select	High, unless Slave
4 and 5	TSCAN, TCKS	Control Test mode	Both low
6	TDI1	Test Data serial input	Low
7	MASTERRESET	General reset, active low	Power-on timer
8	MOT/INTEL	Bus mode select	High for Motorola, low for Intel
9	CS	Chip Select, active low	To microprocessor
10	V_{SS}	Ground	0V
11	V_{DD}	Positive supply	+5V
12	WEN	Write Enable - see mode table, page 3	To microprocessor
13	RW	Read/Write - see mode table, page 3	To microprocessor
14 and 15	TMS2, TMS1	Test Mode Select 2 and 1	Both low
16 and 17	TMAG, TSIGN	Test PRN pattern output	Leave open
18	MAG2	Source 2 MAG input	Low
19	100/219kHz	Clock output	Leave open
20	V_{DD}	Positive supply	+5V
21	V_{SS}	Ground	0V
22	INTOUT	Interrupt output	To microprocessor
23 to 39	SIGN and MAG 1 to 9	Source 1 to 9 SIGN and MAG inputs	All low
40	V_{SS}	Ground	0V
41	V_{DD}	Positive supply	+5V
42 and 43	MAG0, SIGN0	Source Mag and SIGN inputs	To GP1010
44	SAMPCLK	Sampling clock	To GP1010
45	V_{DD}	Positive supply	+5V
46	MASTERCLK	40MHz Master Clock	To GP1010
47	V_{SS}	Ground	0V
48	BIAS	Bias for Master Clock	See Fig. 12 (page 8)
49	V_{SS}	Ground	0V
50	V_{DD}	Positive supply	+5V
51	V_{SS}	Ground	0V
52	CLKSEL	100kHz (high)/219kHz (low) select	High
53	PLLLOCKIN	PLL Status input	Low or GP1010
54	BITECNTL	BITE control to Front-end	Leave open
55	GLONASSBIT	GLONASS BITE input	Low
56	SLAVECLK	Master to Slave clock	Leave open
57	INTIN	Interrupt input for Slave	Low
58 to 65	TCK 1 to 8	Test clocks or signals	All low
66	TICIN	TIC input to Slave	Low
67	TICOUT	TIC output from Master	Leave open
68 and 69	D0 and D1	Data bus	To microprocessor
70	V_{SS}	Ground	0V
71	V_{DD}	Positive supply	+5V
72 and 73	D2 and D3	Data bus	To microprocessor
74	TIMEMARK	1 PPS output	Leave open
75	RTCINT	Real Time Clock interrupt input	Low
76 and 77	MARKFB 1 and 2	Time Mark driver feedback	Both low
78 and 79	D4 and D5	Data bus	To microprocessor
80	V_{DD}	Positive supply	+5V

Continued...

GP1020

PIN CONNECTIONS FOR A SIMPLIFIED SYSTEM (continued)

Pin No.	Signal name	Description	Connection
81	V _{SS}	Ground	0V
82 and 83	D6 and D7	Data bus	To microprocessor
84	WPROG	Bus timing mode select	Low (see note 5)
85 and 86	NANDA and B	Test/spare gate inputs	Low
87	TDO	Boundary Scan output	Leave open
88 and 89	TCK and <u>TRST</u>	Boundary Scan clock and Reset	Both low
90	NANDOP	Test/spare gate output	Leave open
91 and 92	TMS and TDI	Boundary Scan select and input	Both low
93	MARKFB3	Time Mark driver feedback	Low
94	TDO7	Test Data Output 7	Leave open
95	DISCOP	General purpose output pin	Leave open
96 and 97	TDO6 and TDO5	Test Data Outputs 6 and 5	Leave open
98 and 99	D8 and D9	Data bus	To microprocessor
100	V _{SS}	Ground	0V
101	V _{DD}	Positive supply	+5V
102 and 103	D10 and D11	Data bus	To microprocessor
104 to 107	TDO4 to TDO1	Test Data Outputs 4 to 1	Leave open
108 and 109	D12 and D13	Data bus	To microprocessor
110	V _{DD}	Positive supply	+5V
111	V _{SS}	Ground	0V
112 and 113	D14 and D15	Data bus	To microprocessor
114	ALE	Address Latch Enable	To microprocessor
115 to 120	A1 to A6	Address bus	To microprocessor

Notes

1. The action of WEN and RW is given in the table at the foot of page 3.
2. In the above list, it is assumed that only one Front-end is being used and that it is connected to SIGN0 and MAG0. Any other SIGN and MAG pair may be chosen if desired.
3. Unused inputs are listed in the above table as tied low (to ground) so that they are not left floating.
4. Connections listed 'To microprocessor' may, in some systems, be made via glue logic such as address latches.
5. WPROG is used to modify the Write timing. For most applications, WPROG should be tied low. For use with an Intel 486, it may be better to tie WPROG high to delay the start of the Write operation until after the address decode in the GP1020 has settled.
6. ALE is listed as 'To microprocessor' but it is possible in systems with WPROG tied low to have ALE tied high to make the latches in the GP1020 transparent if the address bus is externally latched for the write or read operation.

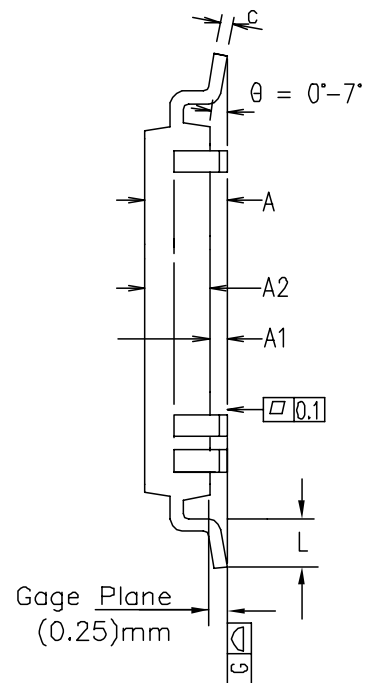
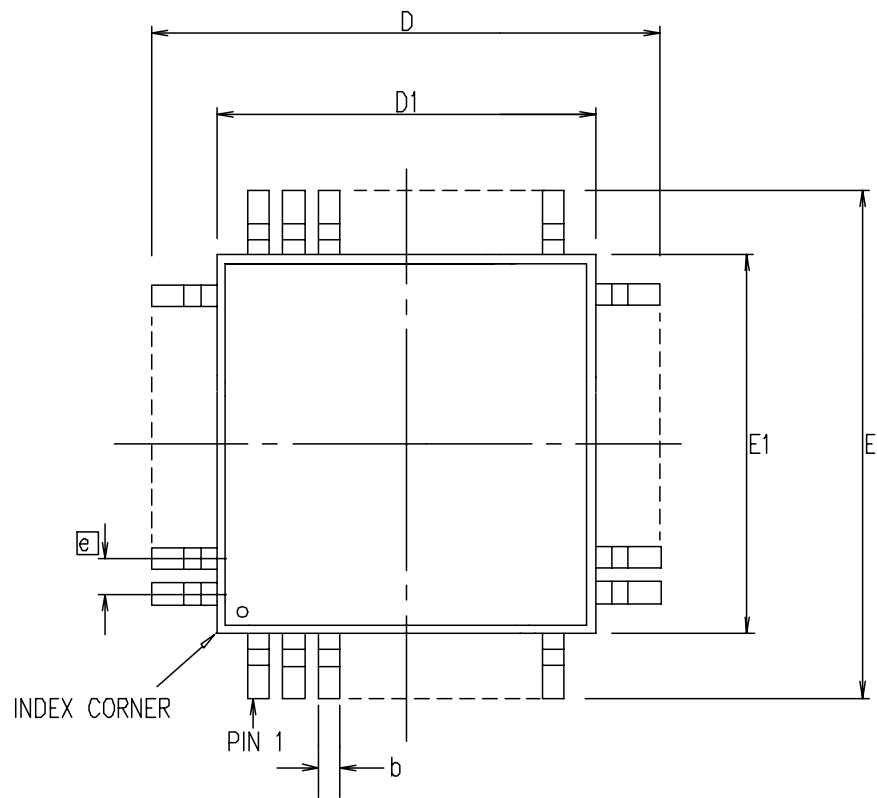

Symbol	Control Dimensions in millimetres		Altern. Dimensions in inches	
	MIN	MAX	MIN	MAX
A	—	4.10	—	0.161
A1	0.25	0.50	0.010	0.020
A2	3.20	3.60	0.126	0.142
D	31.20	BSC	1.228	BSC
D1	28.00	BSC	1.102	BSC
E	31.20	BSC	1.228	BSC
E1	28.00	BSC	1.102	BSC
L	0.73	1.03	0.029	0.041
e	0.80	BSC.	0.031	BSC.
b	0.29	0.45	0.011	0.018
c	0.11	0.23	0.004	0.009
Pin features				
N	120			
ND	30			
NE	30			
NOTE	SQUARE			

Conforms to JEDEC MS-022 DA-1 Iss. B

Notes:

1. Pin 1 indicator may be a corner chamfer, dot or both.
2. Controlling dimensions are in millimeters.
3. The top package body size may be smaller than the bottom package body size by a max. of 0.15 mm.
4. Dimension D1 and E1 do not include mould protusion.
5. Dimension b does not include dambar protusion.
6. Coplanarity, measured at seating plane G, to be 0.010 mm max.

© Mitel

ORIGINATING SITE: SWINDON

ISSUE	1	2			
ACN	202053	207055			
DATE	20FEB97	30JUN99			
APPD.					

MITEL SEMICONDUCTOR

Title: Package Outline Drawing for
120L MQFP (GP)
(28x28x3.4) mm, Body+3.2 mm

Drawing Number

GPD00304



**For more information about all Zarlink products
visit our Web Site at
www.zarlink.com**

Information relating to products and services furnished herein by Zarlink Semiconductor Inc. or its subsidiaries (collectively "Zarlink") is believed to be reliable. However, Zarlink assumes no liability for errors that may appear in this publication, or for liability otherwise arising from the application or use of any such information, product or service or for any infringement of patents or other intellectual property rights owned by third parties which may result from such application or use. Neither the supply of such information or purchase of product or service conveys any license, either express or implied, under patents or other intellectual property rights owned by Zarlink or licensed from third parties by Zarlink, whatsoever. Purchasers of products are also hereby notified that the use of product in certain ways or in combination with Zarlink, or non-Zarlink furnished goods or services may infringe patents or other intellectual property rights owned by Zarlink.

This publication is issued to provide information only and (unless agreed by Zarlink in writing) may not be used, applied or reproduced for any purpose nor form part of any order or contract nor to be regarded as a representation relating to the products or services concerned. The products, their specifications, services and other information appearing in this publication are subject to change by Zarlink without notice. No warranty or guarantee express or implied is made regarding the capability, performance or suitability of any product or service. Information concerning possible methods of use is provided as a guide only and does not constitute any guarantee that such methods of use will be satisfactory in a specific piece of equipment. It is the user's responsibility to fully determine the performance and suitability of any equipment using such information and to ensure that any publication or data used is up to date and has not been superseded. Manufacturing does not necessarily include testing of all functions or parameters. These products are not suitable for use in any medical products whose failure to perform may result in significant injury or death to the user. All products and materials are sold and services provided subject to Zarlink's conditions of sale which are available on request.

Purchase of Zarlink's I²C components conveys a licence under the Philips I²C Patent rights to use these components in and I²C System, provided that the system conforms to the I²C Standard Specification as defined by Philips.

Zarlink, ZL and the Zarlink Semiconductor logo are trademarks of Zarlink Semiconductor Inc.

Copyright Zarlink Semiconductor Inc. All Rights Reserved.

TECHNICAL DOCUMENTATION - NOT FOR RESALE
