

# DELPHI SERIES



## FEATURES

- ◆ ROHS Compliant
- ◆ Small size: 50.8mm x 40.6mm x 12.7mm (2.0" x 1.6" x 0.5")
- ◆ Industry standard footprint and pin-out
- ◆ Optimized for use with high frequency board mounted DC/DC converters
- ◆ Printed-circuit board mountable
- ◆ ISO 9001, TL 9000, ISO 14001, QS 9000, OHSAS 18001 certified manufacturing facility
- ◆ UL/cUL 60950 (US & Canada) Recognized, VDE 0805 (IEC60950) Licensed

## Delphi Series Filter Module - FL75L20 A 75Vdc max input, 20A max output current

The Delphi series FL75L20 A filter module is the latest offering from a world leader in power systems technology and manufacturing -- Delta Electronics, Inc. This filter module is designed to reduce the conducted common-mode and differential-mode noise on input or output lines of high-frequency switching power supplies and has a maximum current rating of 20A. It has the industry standard footprint and pin-out. With creative design technology and optimization of component placement, Delphi FL75L20 A filter module possesses outstanding electrical and thermal performance, as well as extremely high reliability under highly stressful operating conditions.

## APPLICATIONS

- ◆ Common-mode and differential-mode filtering of power supply dc input and output line
- ◆ Computer application
- ◆ Communications equipment

## SPECIFICATIONS

GENERAL SPECIFICATIONS			OUTPUT SPECIFICATIONS		
Input voltage, continuous	Typical	0~75V	Output current	Ta=60°C, 2 m/s	20A
Input voltage, transient	Typical	100V	Output current	Ta=70°C, 0 m/s	12A
Operation case temperature	Typical	-40 ~ 110	Common-mode Insertion Loss	50 circuit, 500 kHz (Typ)	28dB
Storage temperature	Typical	-55 ~ 125	Differential-mode Insertion Loss	50 circuit, 500 kHz (Typ)	46dB
Size	(2.0" x 1.6"x 0.5")	50.8 x 40.6 x 12.7 mm			

## ELECTRICAL CHARACTERISTICS CURVES



Figure 1: Typical common-mode insertion loss in a 50 circuit



Figure 2: Typical differential-mode insertion loss in a 50 circuit

## Internal Schematics

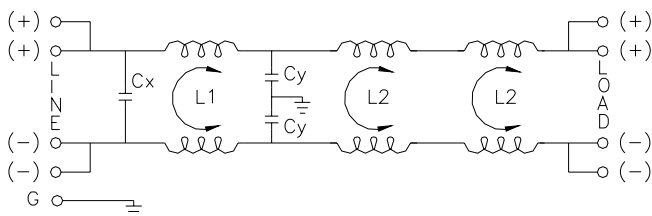

Figure 3: Internal schematics

## THERMAL CONSIDERATIONS

Thermal management is an important part of the system design. To ensure proper, reliable operation, sufficient cooling of the power module is needed over the entire temperature range of the module. Convection cooling is usually the dominant mode of heat transfer.

Hence, the choice of equipment to characterize the thermal performance of the power module is a wind tunnel.

### Thermal Testing Setup

Delta's filter modules are characterized in heated vertical wind tunnels that simulate the thermal environments encountered in most electronics equipment. This type of equipment commonly uses vertically mounted circuit cards in cabinet racks in which the power modules are mounted.

The following figure shows the wind tunnel characterization setup. The filter module is mounted on a test PWB and is vertically positioned within the wind tunnel. The space between the neighboring PWB and the top of the power module is 6.35mm (0.25").

### Thermal Derating

Heat can be removed by increasing airflow over the module. Figure 4 shows maximum output is a function of ambient temperature and airflow rate. To enhance system reliability, the power module should always be operated below the maximum operating temperature. If the temperature exceeds the maximum module temperature, reliability of the unit may be affected.

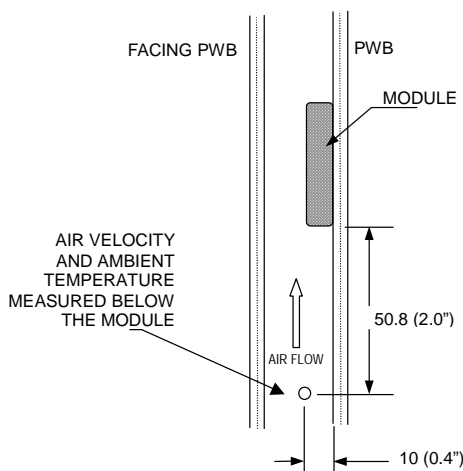

Note: Wind Tunnel Test Setup Figure Dimensions are in millimeters and (Inches)

Figure 4: Wind tunnel test setup figure dimensions are in millimeters and (inches).

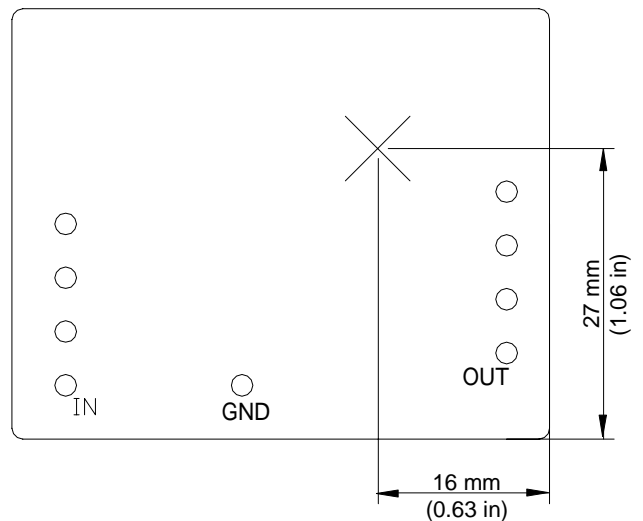

Figure 5: Temperature measurement location  
The allowed maximum hot spot temperature is defined at 110

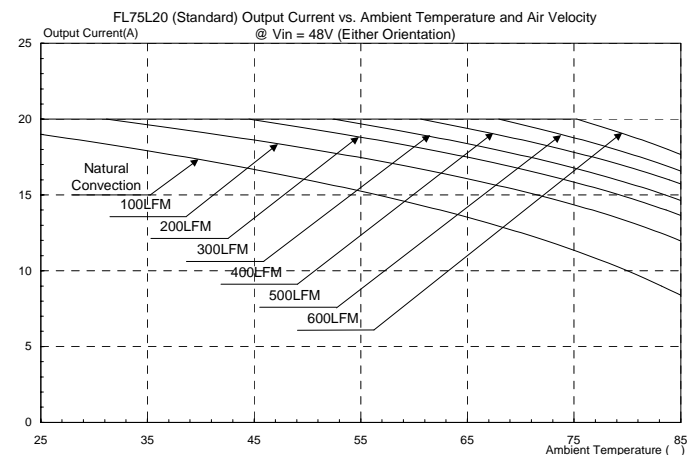
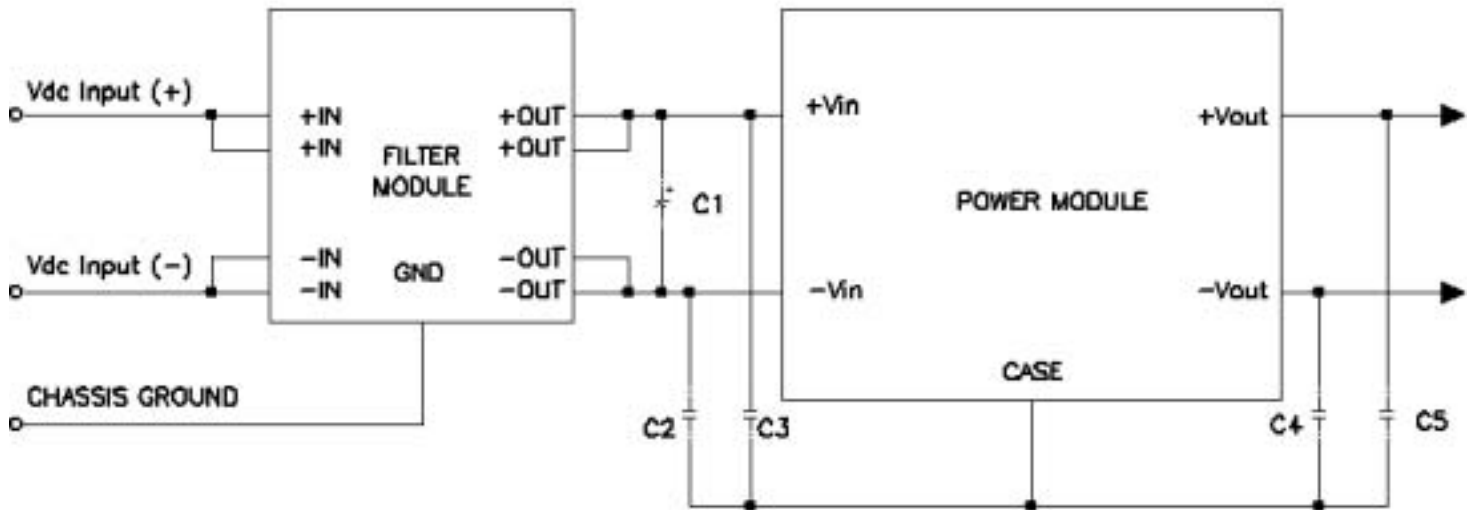

Figure 6: Output Current vs. Ambient Temperature and Air Velocity @ Vin = 48V (Either Orientation)

## APPLICATION



Note: C2 through C5 can be 0.01  $\mu$ F to 0.1  $\mu$ F. Select the voltage rating to meet input-to-output isolation requirements. C1 should be the recommended value indicated in the power module data sheet.

**Figure 7.** Recommended schematic when used as the input filter to a high-frequency dc-to-dc converter

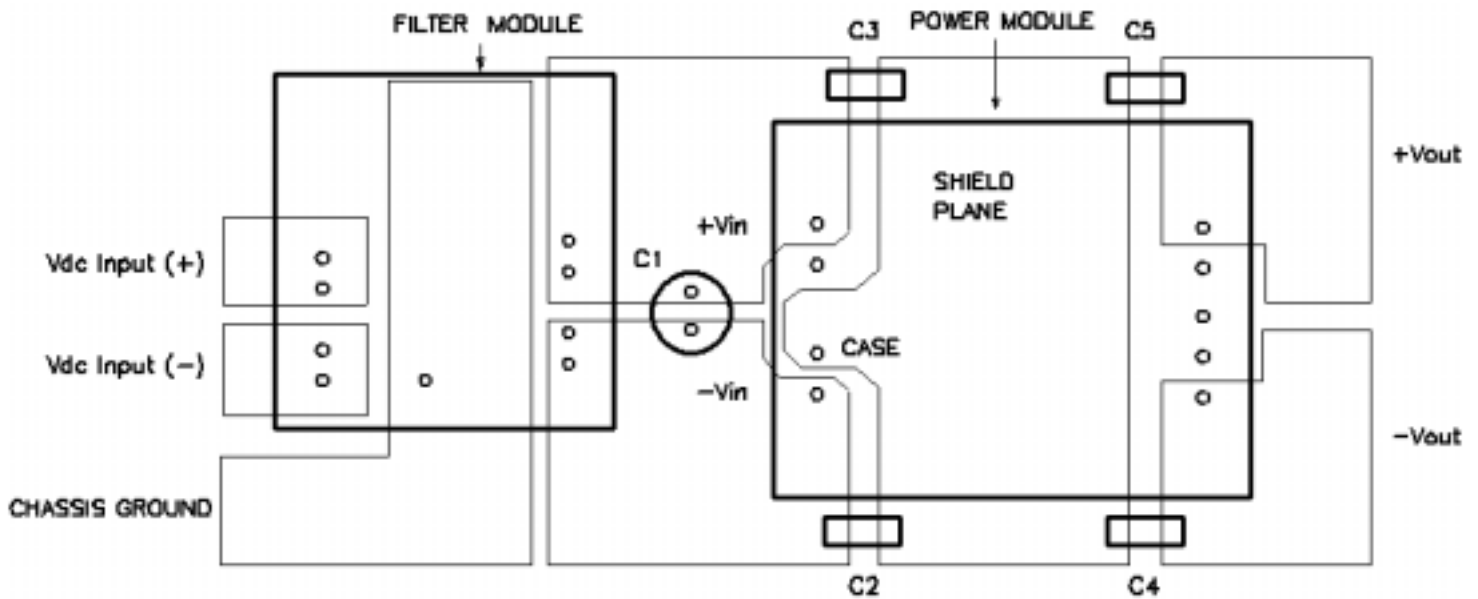

Note: V<sub>dc</sub> input(+) and V<sub>dc</sub> input(-) planes should overlay each other, as should the V<sub>i</sub>(+) and V<sub>i</sub>(-) planes, as should the V<sub>out</sub>(+) and V<sub>out</sub>(-) planes. Avoid routing signals or planes under the power module or the filter module. Ensure all connections are low impedance.

**Figure 8.** Recommended layout when used as the input filter to a high-frequency dc-to-dc converter

## APPLICATION (Continued)

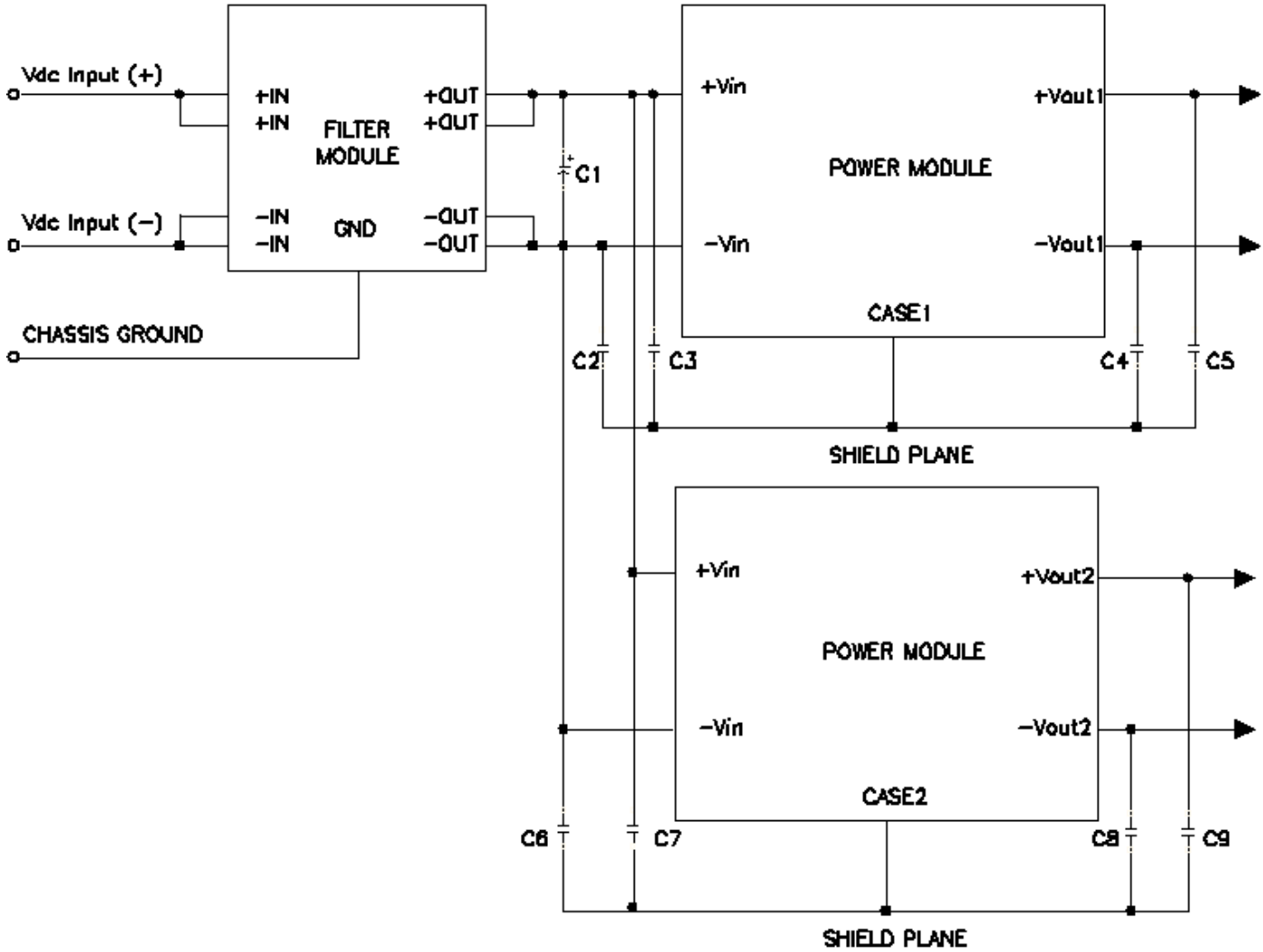

Note : C2 through C5 and C6 through C9 can be  $0.01 \mu\text{F}$  to  $0.1 \mu\text{F}$ . Select the voltage rating to meet input-to-output isolation requirements. C1 should be the recommended value indicated in the power module datasheet.

**Figure 9.** Recommended schematic of filter module with two power modules



Figure 10 shows the experimental result obtained by using this filter module, together with the recommended external components shown in Figures 5 and 6. The Q48SR3R335NR module is one of the Delphi series quarter brick 3.3V, 35A DCDC converters. Measured noise is greatly dependent on layout, grounding, cable orientation, and load characteristics and the variation is possible from various application conditions.

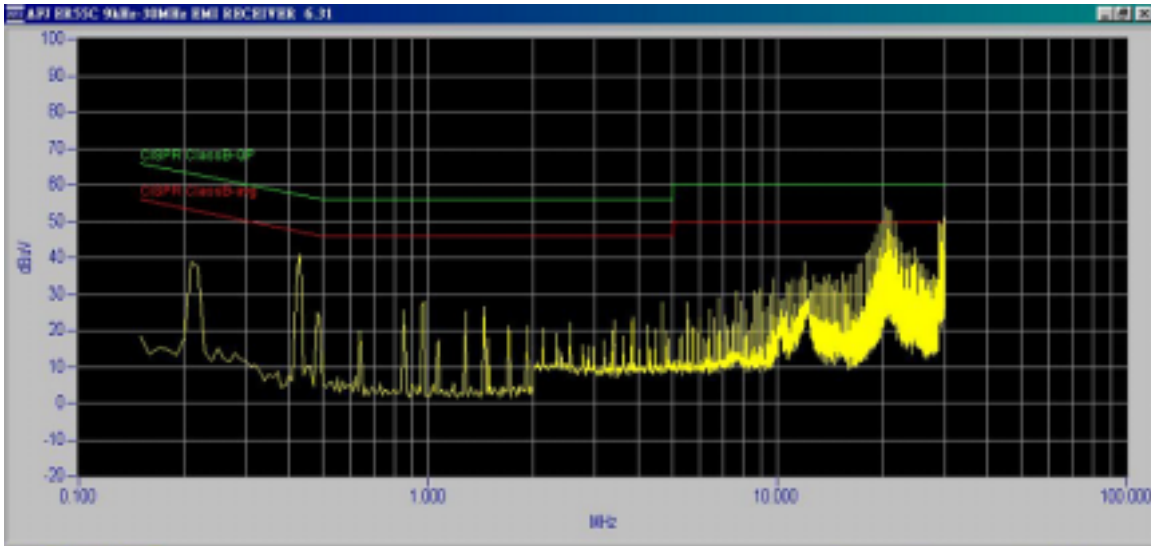
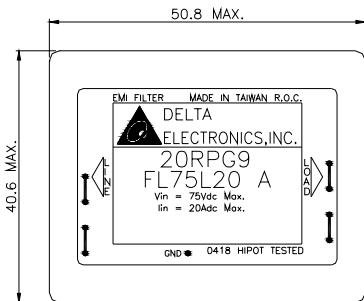

Figure 10. Q48SR3R335NR A conducted noise with FL75L20 input filter

## MECHANICAL DRAWING

### Top View



### Side View

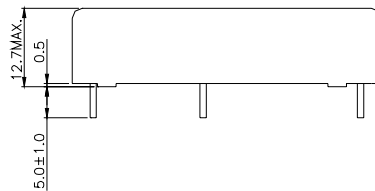

### Bottom View

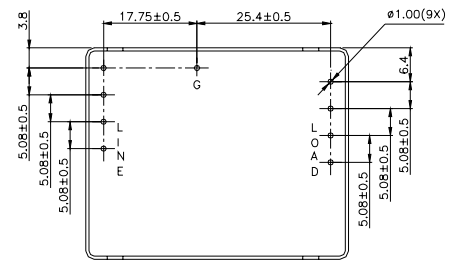

Dimensions are in millimeter and (inches).

Tolerances : x.xx ± 0.5 mm (0.02 in), x.xxx ± 0.25 mm (0.010 in)

## RECOMMENDED HOLE PATTERN

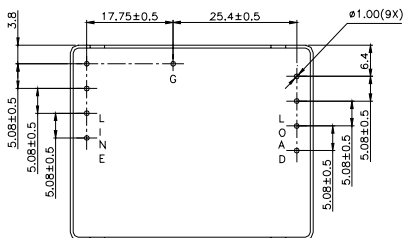

Dimensions are in millimeter and (inches).

Tolerances : x.xx ± 0.5 mm (0.02 in), x.xxx ± 0.25 mm (0.010 in)

## PART NUMBERING SYSTEM

<b>FL</b>	<b>75</b>	<b>L</b>	<b>20</b>		<b>A</b>
<b>Product Family</b>	<b>Input Voltage</b>	<b>Product Series</b>	<b>Output Current</b>	<b>Space</b>	<b>Option Code</b>
FL- EMI Filter	75- 0 ~ 75V	L – Industry standard	20 - 20A		A - Standard Functions

## MODEL LIST

<b>Module Name</b>	<b>Input Voltage (max.)</b>	<b>Current Rating (max.)</b>	<b>Size (metric)</b>	<b>Size (English unit)</b>
FL75L05 A	75V	5A	25.4 x 25.4 x 10.2 mm	1.0 in. x 1.0 in. x 0.4 in.
FL75L10 A	75V	10A	50.8 x 27.9 x 12.5 mm	2.0 in. x 1.1 in. x 0.5 in.
FL75L20 A	75V	20A	50.8 x 40.6 x 12.7 mm	2.0 in. x 1.6 in. x 0.5 in.

### CONTACT: [www.delta.com.tw/dcdc](http://www.delta.com.tw/dcdc)

#### USA:

Telephone:  
East Coast: (888) 335 8201  
West Coast: (888) 335 8208  
Fax: (978) 656 3964  
Email: [DCDC@delta-corp.com](mailto:DCDC@delta-corp.com)

#### Europe:

Telephone: +41 31 998 53 11  
Fax: +41 31 998 53 53  
Email: [DCDC@delta-es.tw](mailto:DCDC@delta-es.tw)

#### Asia & the rest of world:

Telephone: +886 3 4526107 ext 6220  
Fax: +886 3 4513485  
Email: [DCDC@delta.com.tw](mailto:DCDC@delta.com.tw)

## WARRANTY

Delta offers a two (2) year limited warranty. Complete warranty information is listed on our web site or is available upon request from Delta.

Information furnished by Delta is believed to be accurate and reliable. However, no responsibility is assumed by Delta for its use, nor for any infringements of patents or other rights of third parties, which may result from its use. No license is granted by implication or otherwise under any patent or patent rights of Delta. Delta reserves the right to revise these specifications at any time, without notice.