

FAN8729

Spindle+4-CH Motor Drive IC

Features

- Built-in Power Save Circuit
- Built-in Current Limit Circuit
- Built-in Thermal Shutdown Circuit (TSD)
- Built-in TSD Monitor Circuit
- Built-in FG Signal Output Circuit
- Built-in Rotational Direction Detecting Circuit
- Built-in Protection Circuit For Reverse Rotation
- Built-in 4-CH Balanced Transformerless (BTL) Driver
- Built-in BTL MUTE Circuit (CH123 and CH4)
- Corresponds to 3.3V DSP

Description

The FAN8729 is a monolithic integrated circuit built-in 4Channel BTL motor and spindle motor drivers, which can drive tracking actuator, focus actuator, sled motor, loading motor, 3-phase BLDC motor, and it is applicable to DVD-P/MDP/CAR-MD/CAR-NAVIGATION systems.



Typical Application

- Mini Disk Player
- Digital Video Disk Player
- Car Mini Disk Player
- Car navigation System

Ordering Information

Device	Package	Operating Temperature
FAN8729	48-QFPH-1414	-35°C ~ +85°C
FAN8729_NL*note	48-QFPH-1414	-35°C ~ +85°C

***Note:**

NL: Lead free Type

Pin Assignments

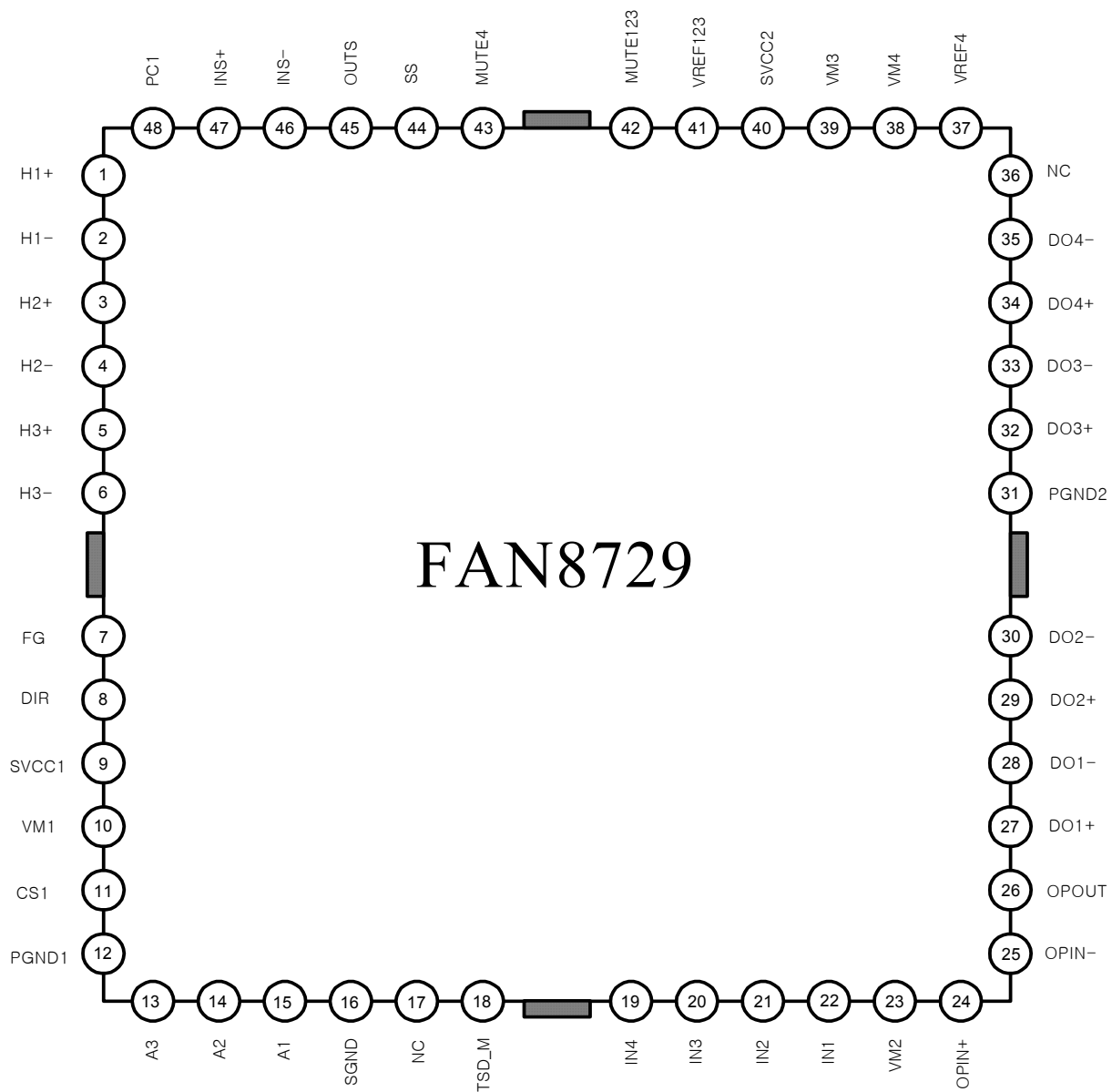

Pin Definitions

Pin Number	Pin Name	I/O	Pin Function Description
1	H1+	I	Hall1(+) Input
2	H1-	I	Hall1(-) Input
3	H2+	I	Hall2(+) Input
4	H2-	I	Hall2(-) Input
5	H3+	I	Hall3(+) Input
6	H3-	I	Hall3(-) Input
7	FG	O	FG Output
8	DIR	O	Direction
9	SVCC1	-	Signal VCC1
10	VM1	-	BLDC Motor Power Supply
11	CS1	I	Current Sensor
12	PGND1	-	Power Ground1
13	A3	O	3-Phase Output 3
14	A2	O	3-Phase Output 2
15	A1	O	3-Phase Output 1
16	SGND	-	Signal Ground
17	NC	-	NC
18	TSD_M	O	TSD Monitor
19	IN4	I	CH4 Input
20	IN3	I	CH3 Input
21	IN2	I	CH2 Input
22	IN1	I	CH1 Input
23	VM2	-	BTL CH1,2 Supply Voltage
24	OPIN+	I	Normal OP-AMP Input(+)
25	OPIN-	I	Normal OP-AMP Input(-)
26	OPOUT	O	Normal OP-AMP Output
27	DO1+	O	BTL Drive 1 Output(+)
28	DO1-	O	BTL Drive 1 Output(-)
29	DO2+	O	BTL Drive 2 Output(+)
30	DO2-	O	BTL Drive 2 Output(-)
31	PGND2	-	BTL Power Ground2
32	DO3+	O	BTL Drive 3 Output(+)
33	DO3-	O	BTL Drive 3 Output(-)

Pin Definitions (Continued)

Pin Number	Pin Name	I/O	Pin Function Description
34	DO4+	O	BTL Drive 4 Output(+)
35	DO4-	O	BTL Drive 4 Output(-)
36	NC	-	NC
37	VREF4	I	BTL CH4 Reference
38	VM4	-	BTL CH4 Motor Supply
39	VM3	-	BTL CH3 Motor Supply
40	SVCC2	-	BTL Signal VCC
41	VREF123	I	BTL CH1,2,3 Reference
42	MUTE123	I	BTL CH1,2,3 Mute
43	MUTE4	I	BTL CH4 Mute
44	SS	I	Spindle Start/Stop
45	OUTS	O	OP-AMP Spindle Output
46	INS-	I	OP-AMP Spindle Input(-)
47	INS+	I	OP-AMP Spindle Input(+)
48	PC1	I	Phase Compensation Cap.

Internal Block Diagram

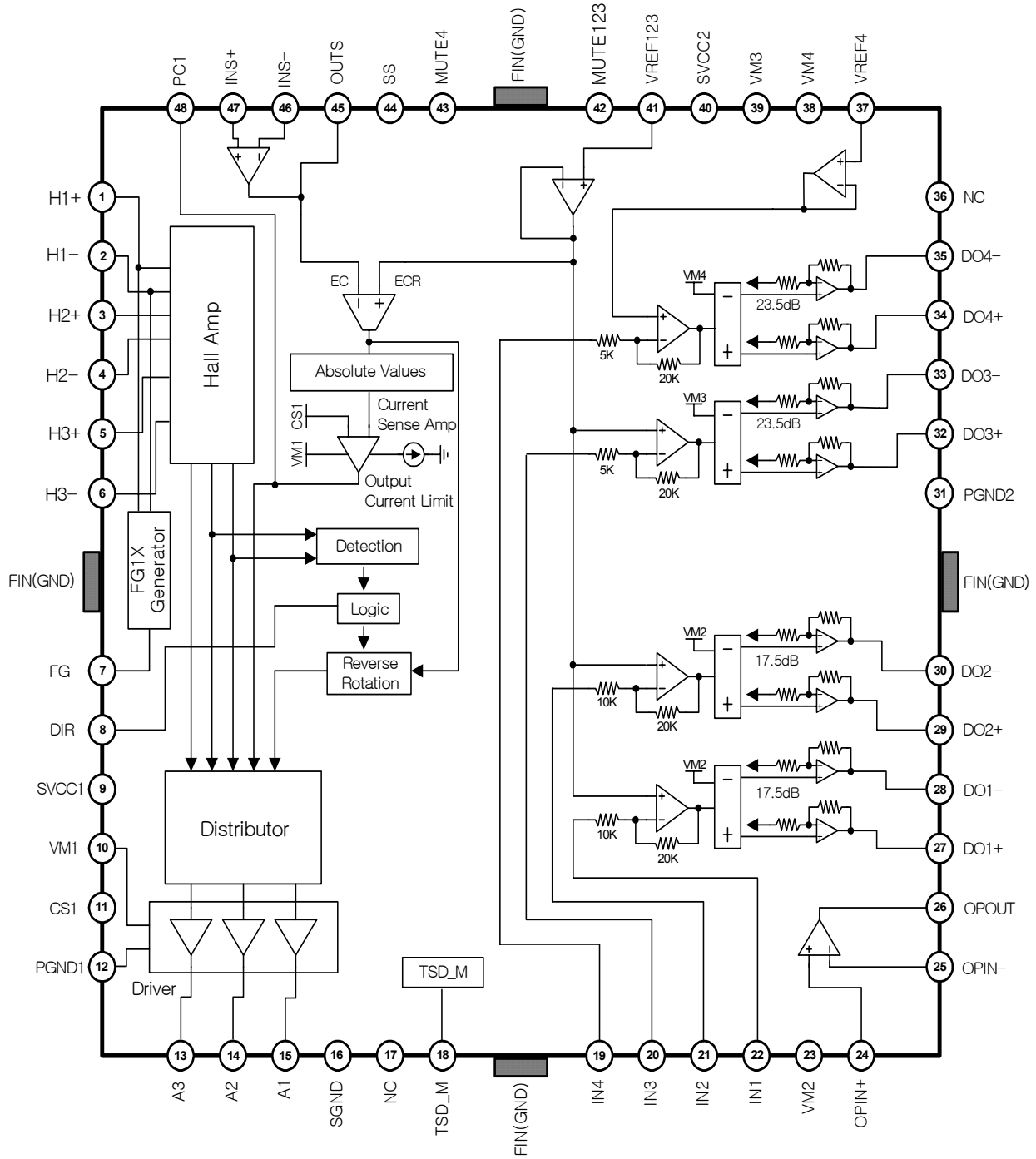

Equivalent Circuits

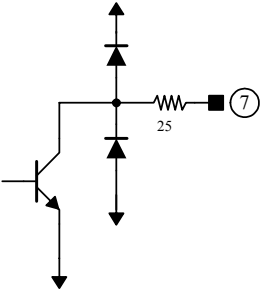
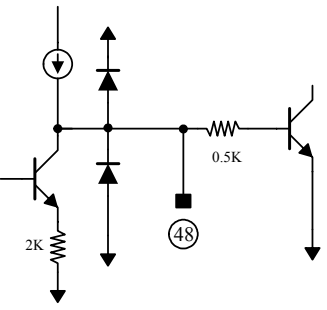
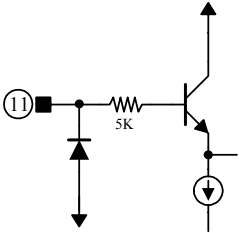
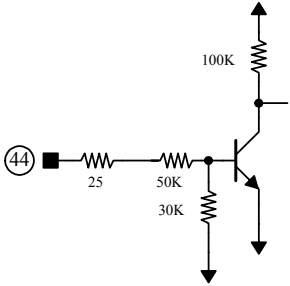
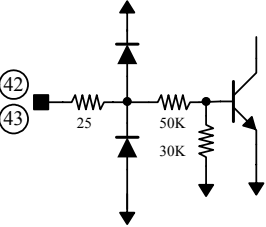
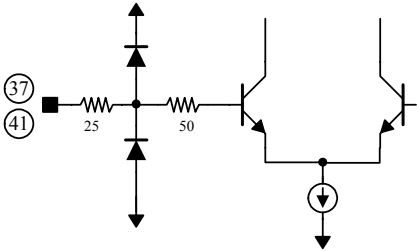
FG Signal Output	Phase Compensation Capacitor
	
Current Detector	Start/Stop
	
BTL Drive Mute	BTL Bias Voltage
	

Equivalent Circuits (Continued)

<p style="text-align: center;">3-Phase Rotational Direction Output</p>	<p style="text-align: center;">BTL Drive Output</p>
<p style="text-align: center;">3-Phase Output</p>	<p style="text-align: center;">TSD_M</p>
<p style="text-align: center;">BTL Input(CH1,2)</p>	<p style="text-align: center;">BTL Input(CH3,4)</p>
<p style="text-align: center;">OP-AMP Input</p>	<p style="text-align: center;">OP-AMP Output</p>
<p style="text-align: center;">SVCC</p>	<p style="text-align: center;">SVCC</p>

Absolute Maximum Ratings (Ta=25°C)

Parameter	Symbol	Value	Unit
Supply Voltage (Spindle Signal)	SVCC1max	7	V
Supply Voltage (BTL Signal)	SVCC2max	15	V
Supply Voltage (Spindle Motor)	VM1max	15	V
Supply Voltage (BTL Motor)	VM2,3,4max	15	V
Power Dissipation	Pd	2.7 ^{note}	W
Operating Temperature Range	Topr	-35 ~ +85	°C
Storage Temperature Range	Tstg	-55 ~ +150	°C
Maximum Output Current (Spindle Part)	IOMAXS	1.3	A
Maximum Output Current (BTL Part)	IOMAXB	1	A

Note:

1. When mounted on the PCB (phenolic resin material) of which size is 114mm × 76mm x1.6mm.
2. Power dissipation is reduced with the rate of -21.6mW/°C for TA≥25°C.
3. Do not exceed Pd and SOA.

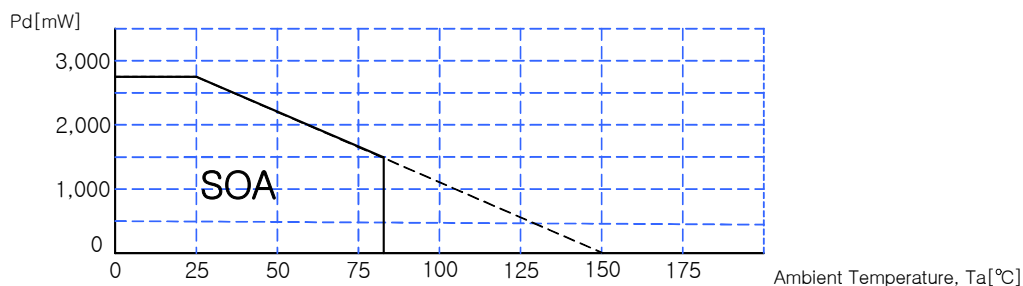

Recommended Operating Conditions (Ta=25°C)

Parameter	Symbol	Min.	Type.	Max.	Unit
Operating Supply Voltage (Spindle Signal)	SVCC1	4.5	-	5.5	V
Operating Supply Voltage (BTL Signal)	SVCC2	4.5	-	13.2	V
Operating Supply Voltage (Spindle Motor)	VM1	4.5	-	13.2	V
Operating Supply Voltage (BTL Motor)	VM2,3,4	4.5	-	SVCC2	V

Electrical Characteristics

(Unless otherwise specified, Ta=25°C, SVCC1=5V, VM1=8V, BTL driver part: SVCC2=9V, VM2=5V, RL1=8Ω, VM3=8V, VM4=9V, RL2=15Ω)

Parameter	Symbol	Condition	Min.	Typ.	Max.	Unit
Circuit Current 2	ICC2	Start/Stop =5V	-	4.5	-	mA
START/STOP						
SS On Voltage Range	VSSON	L-H Circuit On	2.5	-	-	V
SS Off Voltage Range	VSSOFF	H-L Circuit Off	-	-	1.0	V
HALL AMP						
Hall Bias Current	IHA	-	-	1	5	uA
Common Mode Voltage Range	VHAR	-	1.5	-	4.0	V
Minimum In Level	VINH	-	60	-	-	mVpp
TORQUE CONTROL						
EC Input Voltage Range	EC		0.5	-	3.3	V
Offset Voltage (-)	ECOFF-	ECR=1.65V	-100	-50	-20	mV
Offset Voltage (+)	ECOFF+	ECR=1.65V	20	50	100	mV
Input Current	ECIN	EC=ECR=1.65V	-5	-1	-	uA
In/Output Gain	GEC	ECR=1.65V, RCS=0.5Ω	0.56	0.71	0.84	A / V
FG						
FG Output Voltage (L)	VFHL	IFG=10uA	-	-	0.5	V
Input Voltage Range	VFGR	Hn+, Hn- Input D-range	1.5	-	4.0	V
OUTPUT BLOCK						
Saturation Voltage (Upper TR)	VOH	IO= -300mA	-	0.9	1.6	V
Saturation Voltage (Lower TR)	VOL	IO=300mA	-	0.2	0.6	V
Torque Limit Current	ITL	RCS=0.5Ω	560	700	840	mA
DIRECTION DETECTOR						
DIR Output Voltage (L)	VDIRL	IDIR=10uA	-	-	0.5	V

Electrical Characteristics (continued)

(Unless otherwise specified, Ta=25°C, SVCC1=5V, VM1=8V, BTL driver part: SVCC2=9V, VM2=5V, RL1=8Ω, VM3=8V, VM4=9V, RL2=15Ω)

Parameter	Symbol	Condition	Min.	Typ.	Max.	Unit
BTL DRIVE PART						
Quiescent Circuit Current	ICC3	-	-	16.5	-	mA
CH MUTE123 Off Voltage	VMOFF123	Pin42 = Variation	2.5	-	-	V
CH MUTE123 On Voltage	VMON123	Pin42 = Variation	-	-	1.0	V
CH MUTE4 Off Voltage	VMOFF4	Pin43 = Variation	2.5	-	-	V
CH MUTE4 On Voltage	VMON4	Pin43 = Variation	-	-	1.0	V
CH1,2 Actuator Driver (SVCC2=9V, VM2=5V, RL1=8Ω)						
Output Offset Voltage	VOF1,2	VIN = 1.65V	-50	-	+50	mV
Maximum Output Voltage1,2	VOM1,2	VIN = 1.65V	3.6	4.0	-	V
Close Loop Voltage Gain	GVC1,2	f=1kHz, VIN= -0.1Vrms	15.5	17.5	19.5	dB
Ripple Rejection Ratio*note	RR1,2	f=120Hz, VIN= -20dB	-	60	-	dB
Slew Rate 1,2*note	SR1,2	f=120Hz, 2Vp-p	-	1.0	-	V/us
CH3 BTL Driver (SVCC2=9V, VM3=8V, RL2=15Ω)						
Output Offset Voltage3	VOF3	VIN = 1.65V	-100	-	+100	mV
Maximum Output Voltage3	VOM3	VIN = 1.65V	6.5	7.0	-	V
Close Loop Voltage Gain	GVC3	f= 1kHz, VIN= -0.1Vrms	21.5	23.5	25.5	dB
Ripple Rejection Ratio3*note	RR3	f= 120Hz, VIN= -20dB	-	60	-	dB
Slew Rate 3*note	SR3	f= 120Hz, 2Vp-p	-	1.0	-	V/us
CH4 BTL Driver (SVCC2=9V, VM4=9V, RL2=15Ω)						
Output Offset Voltage4	VOF4	VIN = 1.65V	-100	-	+100	mV
Maximum Output Voltage4	VOM4	VIN = 1.65V	7.0	7.5	-	V
Close Loop Voltage Gain	GVC4	f= 1kHz, VIN= -0.1Vrms	21.5	23.5	25.5	dB
Ripple Rejection Ratio4*note	RR4	f= 120Hz, VIN= -20dB	-	60	-	dB
Slew Rate 4*note	SR4	f= 120Hz, 2Vp-p	-	1.0	-	V/us
OP- AMP						
Input Offset Voltage	VOF	-	-20	-	+20	mV
Input Bias Current	IB1	-	-	-	300	nA
High Level Output Voltage	VOHOP	-	8	-	-	V
Low Level Output Voltage	VOLOP	-	-	-	0.1	V
Output Sink Current	ISINK	-	-	5.5	-	mA
Output Source Current	ISOURCE	-	-	4.5	-	mA
Open Loop Voltage Gain*note	GVOOP	f= 1kHz, VIN= -75dB	-	75	-	dB
Ripple Rejection Ratio*note	RROP	f= 120Hz, VIN= -20dB	-	65	-	dB
Slew Rate*note	SROP	f= 120Hz, 2Vp-p	-	1	-	V/us
Common Mode Rejection Ratio*note	CMRROP	f= 1kHz, VIN= -20dB	-	80	-	dB

Note: Guaranteed field.(No EDS/Final test)

Application Information

1. MUTE Function

- MUTE circuit turns BTL output ON/OFF.
- When MUTE terminal (pin42, pin43) is OPEN, or terminal voltage is lower than 1V, BTL is disable.
- When MUTE terminal (pin42, pin43) is voltage is higher than 1.5V, BTL output operates normally.
- Feature Table.

MUTE circuit voltage	MUTE status
Above 1.5V	OFF
Below 1V or Open	ON

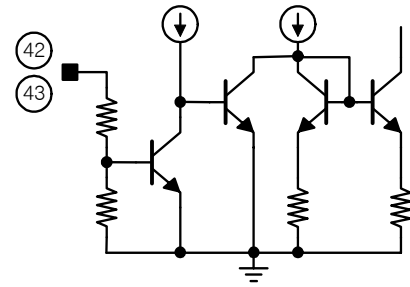

2. TSD Function

- TSD circuit intercepts all IC output to protect the IC against high temperatures.
- When chip temperature rises above 165°C, BTL and spindle output is disable.
- When chip temperature falls below 140°C, BTL and spindle output operates normally.
- TSD has hysteresis of 25°C.

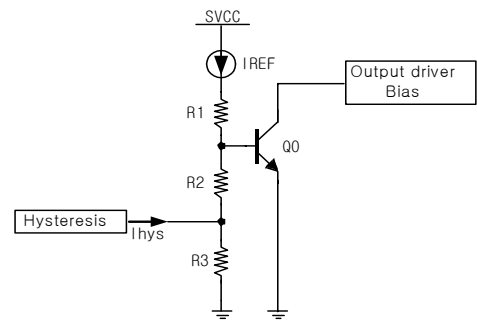

3. TSD Monitor Function

- TSD monitor circuit displays TSD status.
- When TSD is ON, pin18 is HIGH.
- When TSD is OFF, pin18 is LOW.
- Since output pin(PIN18) is open-collector, pull-up resistance should be attached outside.
- Feature Table.

TSD	Pin18
TSD On	High
TSD Off	Low

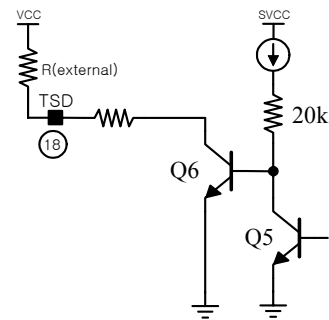

4. CH1,2,3,4 Balanced Transformerless (BTL) Drive

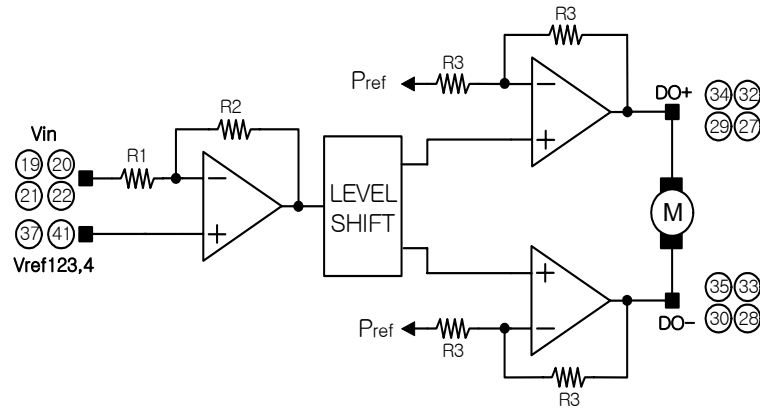

- Diagram above shows each input/output BTL channel structure.
- When BTL input voltage is V_{ref} , the output voltage is P_{ref} . P_{ref} has the value of $V_M/2$.
- BTL Channel's output voltage is found as follows;

$$Do+ = P_{ref} + \frac{R2}{R1} \times \left(1 + \frac{R3}{R3}\right) \times (V_{in} - V_{ref})$$

$$Do- = P_{ref} - \frac{R2}{R1} \times \left(1 + \frac{R3}{R3}\right) \times (V_{in} - V_{ref})$$

- BTL gain value is found as follows;

$$Gain = 4 \times \frac{R2}{R1}$$

5. Spindle

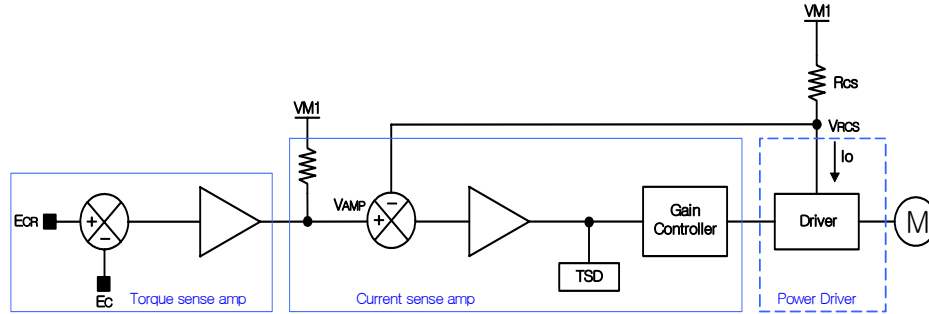

- The spindle driver circuit consists of 3 section: Torque sense amp, Current sense amp, and Power driver.
- Torque sense amp compares and amplifies EC and ECR signals from SERVO, and sends them to current sense amp. With voltage comparison, it determines the signal as forward or reverse.
- Current sense amp limits the current in Motor(I_o) by comparing output current signal from torque sense amp with the current of RCS.
- Power driver output the current to the motor based on the current generated form current sense amp.
- Feature Table

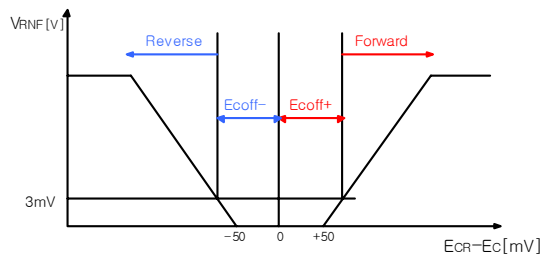

	Rotation
$EC < ECR$	Forward rotation
$EC > ECR$	Stop after detecting reverse rotation

6. Calculation of Gain & Torque Current

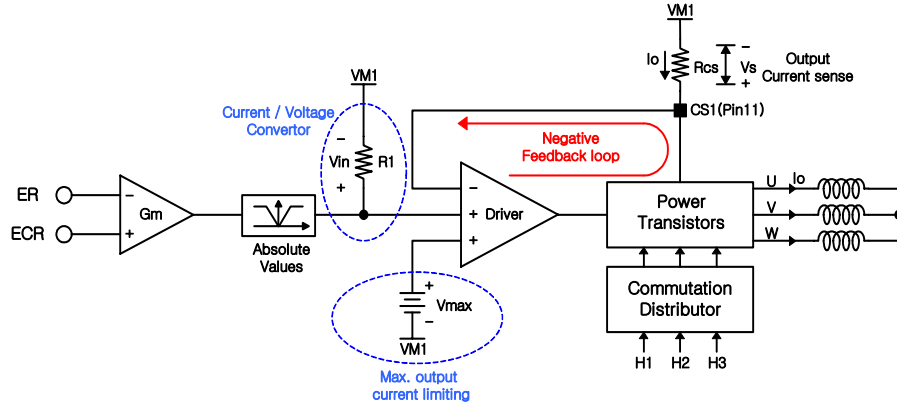

- Torque limit circuit limits the current of spindle motor.
- Driver amp circuit limits the current of spindle motor by comparing the voltage detected from RCS and the voltage output from torque sense map.
- Output current of the motor can be limited by adjusting the RCS value.
- Maximum output current of motor is found as follows;

$$I_o[mA] = \frac{V_{\max}}{R_{cs}} = \frac{350mV}{R_{cs}}$$

- VMAX within IC is fixed at 350mV.
- Gm of torque sense amp is set to 0.71.

7. Rotational Direction Detecting Function

- Rotation detection circuit gives the result to DIR pin by detecting the MD's rotational direction.
- Detects the MD's rotational direction using hall signals H2 and H3.
- Feature Table.

	Rotation	DIR
EC < ECR	Forward	Low
EC > ECR	Reverse	High

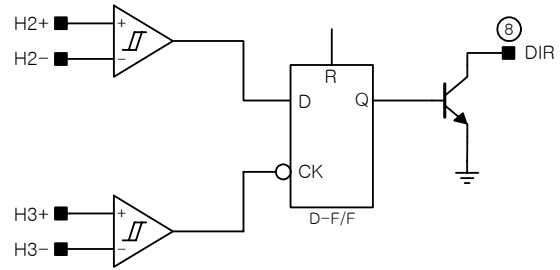

- In case of forward rotational detection, the phase of hall signal shows as H3 → H2 → H1 as follows;

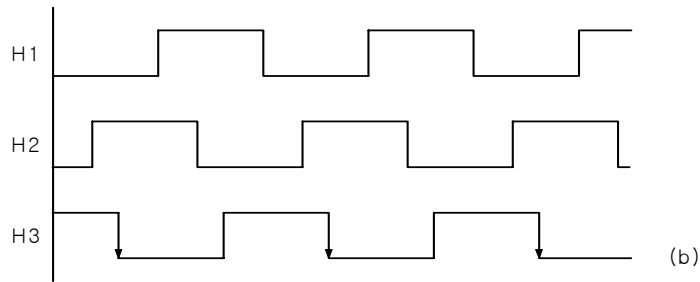

- In case of reverse rotational detection, the phase of hall signal shows as H1 → H2 → H3 as follows;

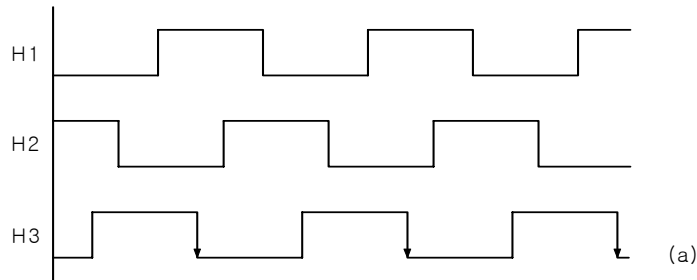

- Forward/Reverse rotational direction is decided as follows. When hall signal H3 is falling edge, if H2 shows "High", the rotational direction is "Forward", and if H2 shows "Low", rotational direction is "Reverse".

8 Reverse Rotation Preventing Function

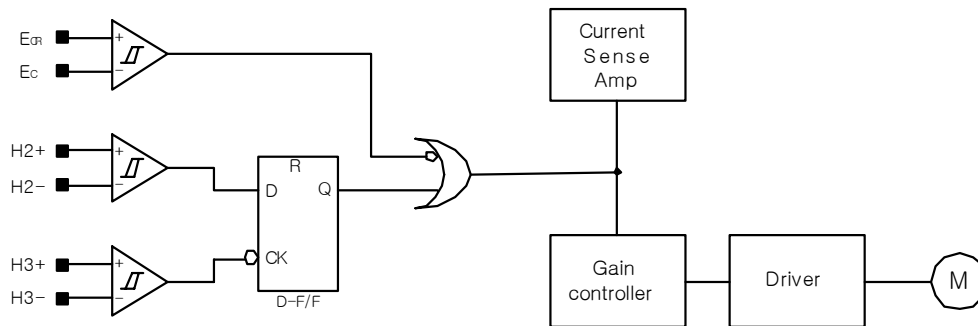

- Reverse rotation prevention circuit has a function for intercepting the reverse rotation of MD.
- When SERVO control input is $EC < ECR$, MD rotates forward and Q which is the output of D-F/F goes "High".
- When SERVO control input is $EC > ECR$, motor puts on reverse brake and MD speed is rapidly reduced.
- When SERVO control input remains $EC > ECR$, MD rotates reverse and Q which is the output of D-F/F goes "Low", in result current sense amp is interrupted. Accordingly gain controller goes OFF and motor is stopped.
- Feature Table.

Rotation	H2	H3	D-F/F	DIR	Reverse Rotation Preventer	
					$EC < ECR$	$EC > ECR$
Forward	H	H → L	H	L	Forward	Brake and Stop
Reverse	L	H → L	L	H	–	Stop

8. FG Output Function

- FG circuit outputs the number of motor rotation.
- One pulse per rotation is output of FG.
- FG uses hall signal H1 as its input, and creates output using hysteresis comparator.
- Input/Output wavelength is shown below;

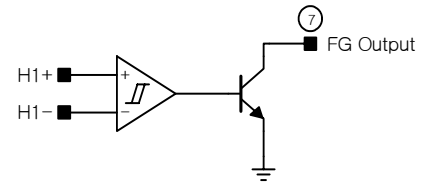
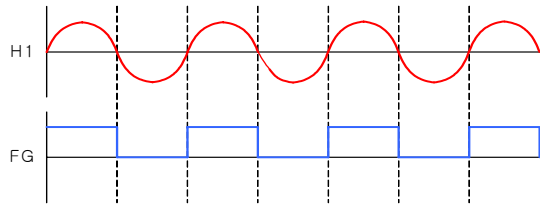

9. Hall Input Output Timing Chart

- Output voltage and current wavelength of each of the 3-phase hall input is shown below.
- The following diagram is the motor's output wavelength in the forward rotation direction.

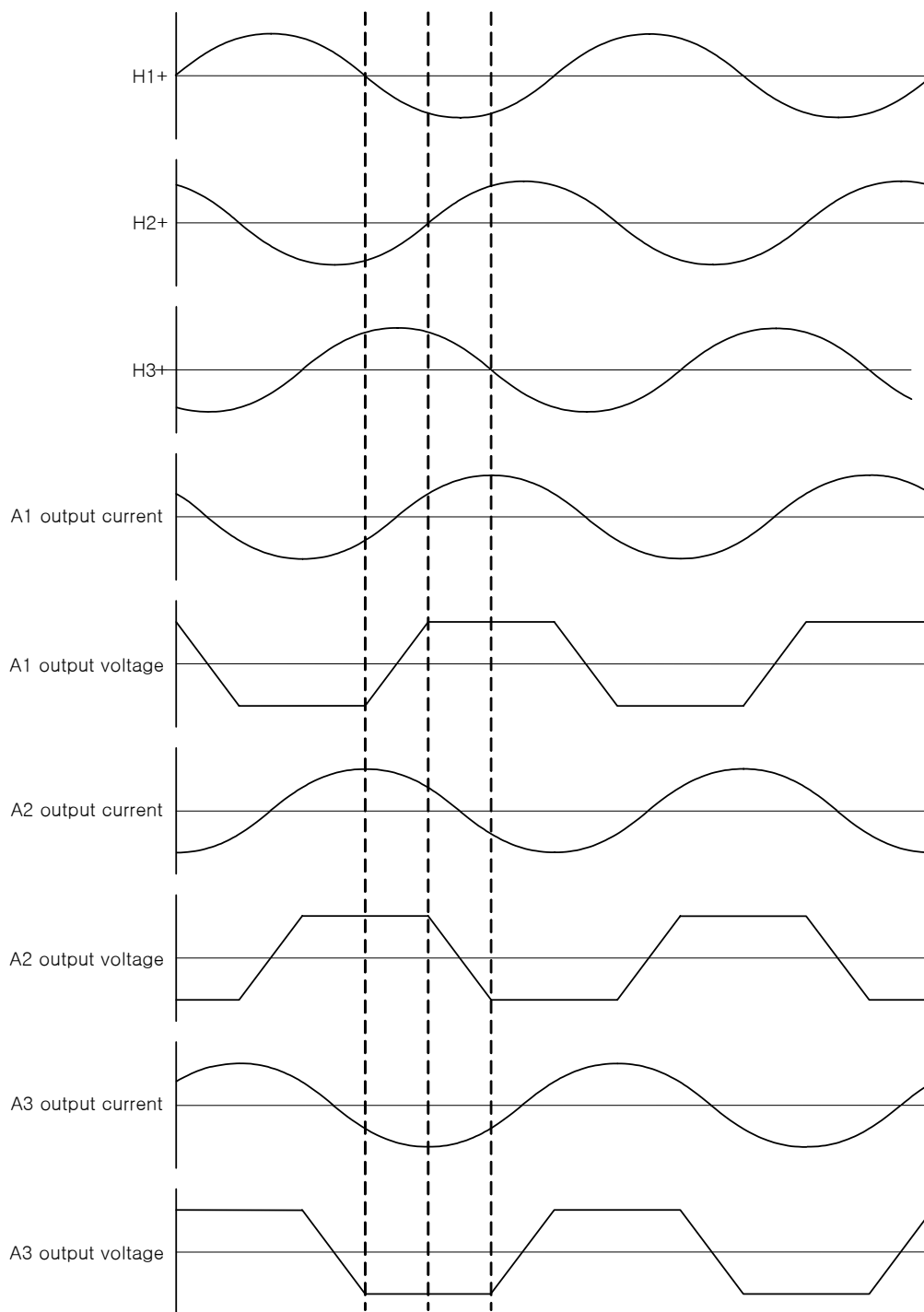

Typical Performance Characteristics

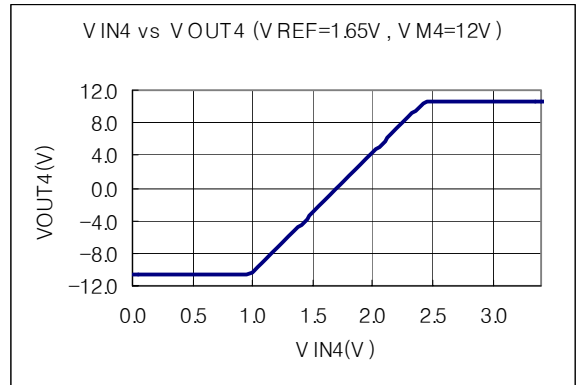
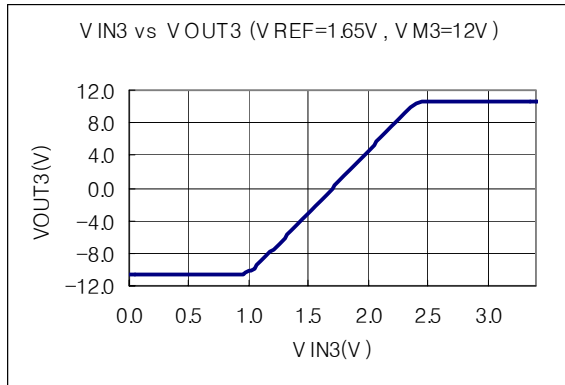
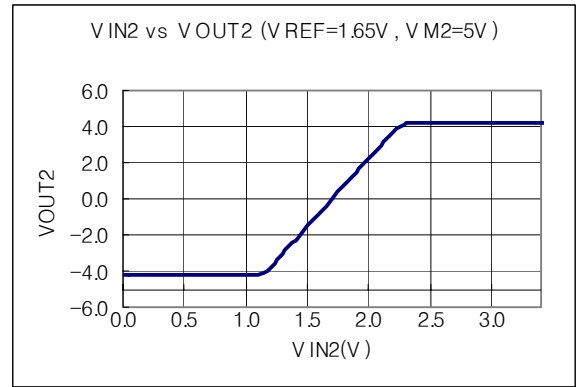
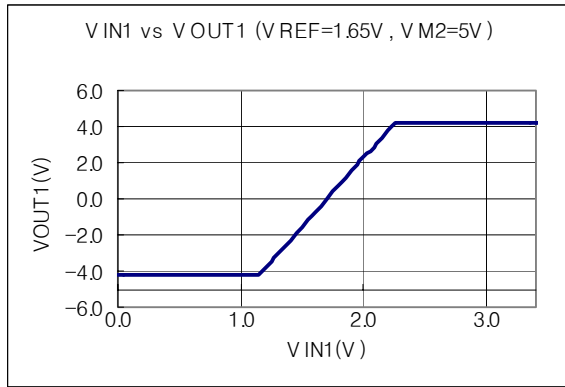
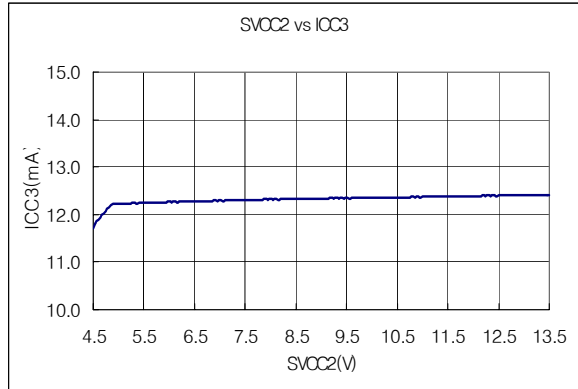
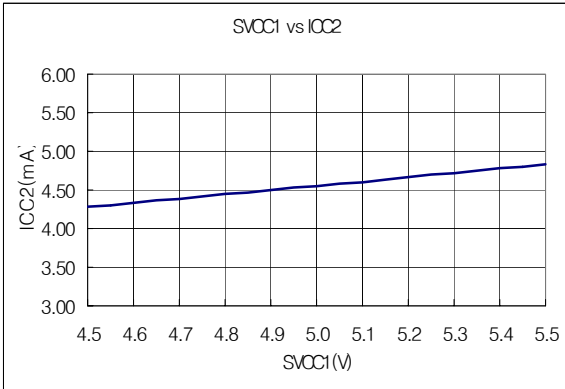

Typical Performance Characteristics

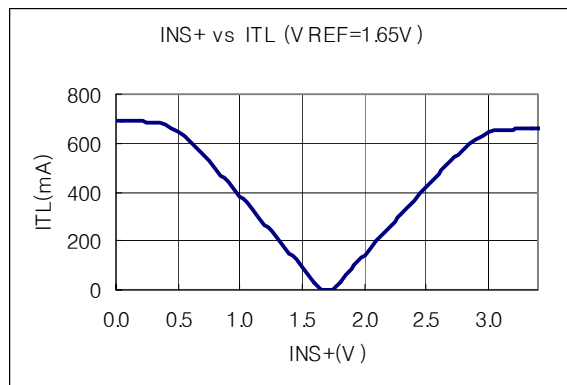
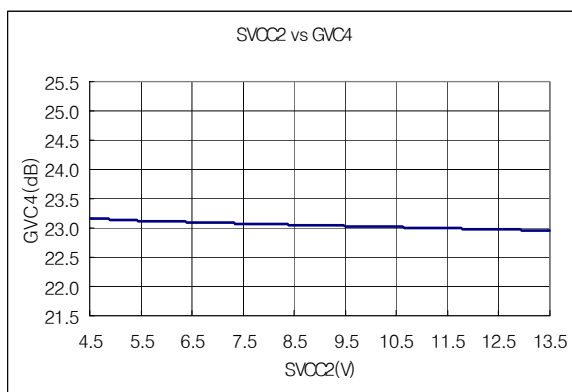
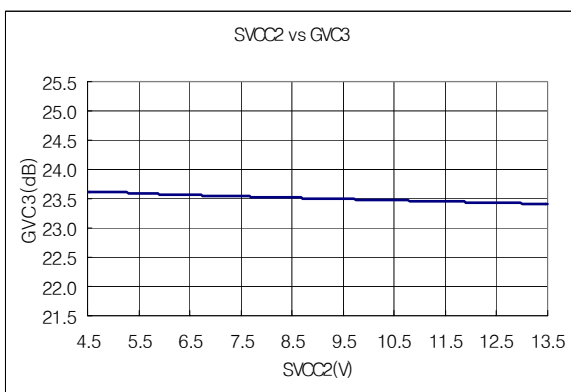
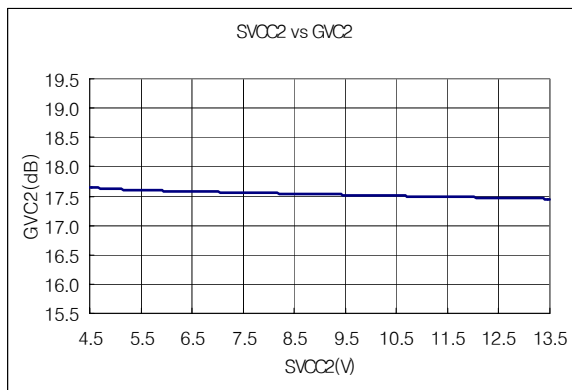
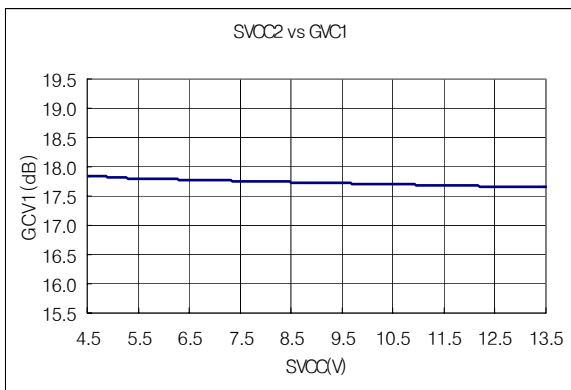

Test Circuits

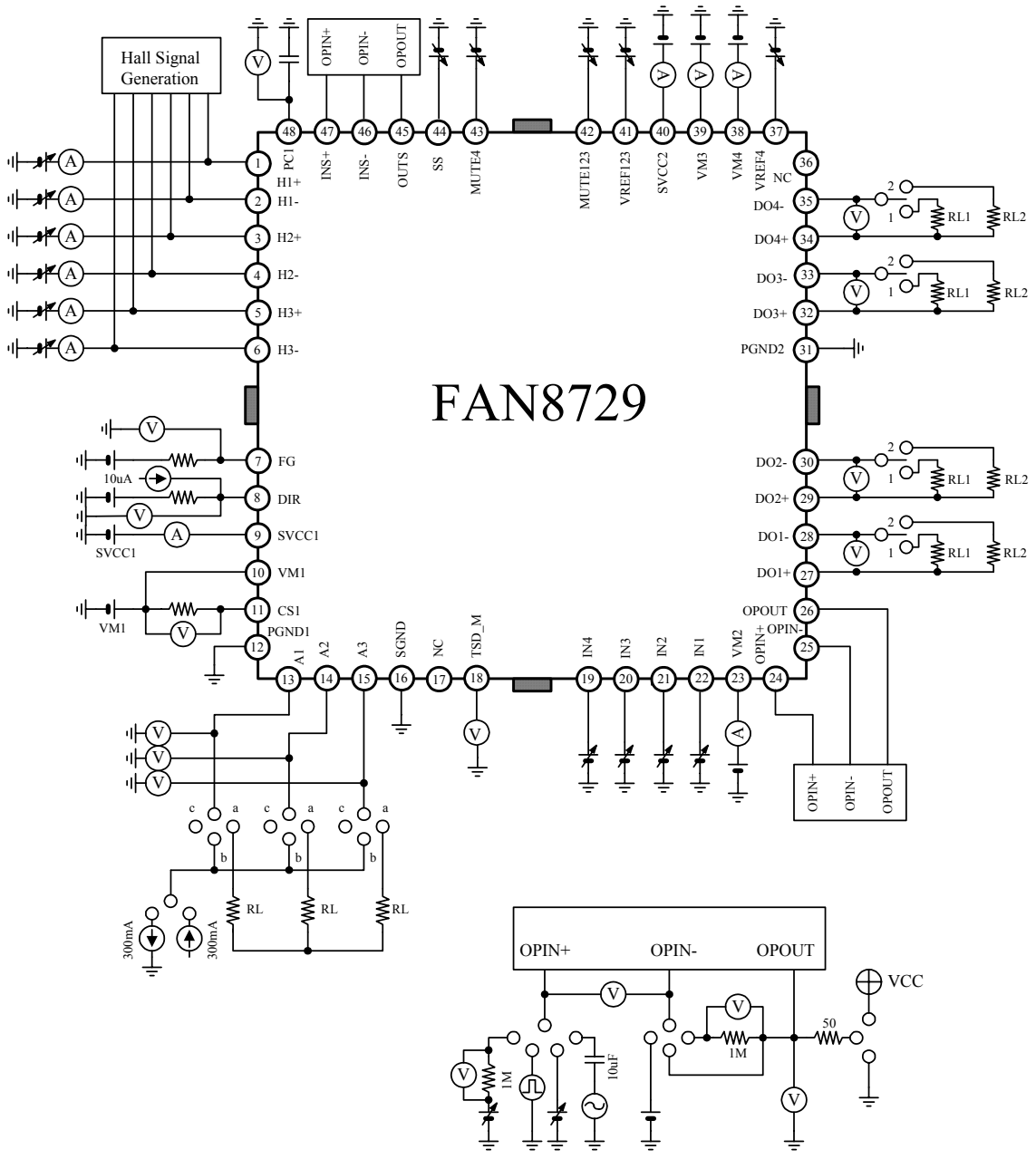

Typical Application Circuits

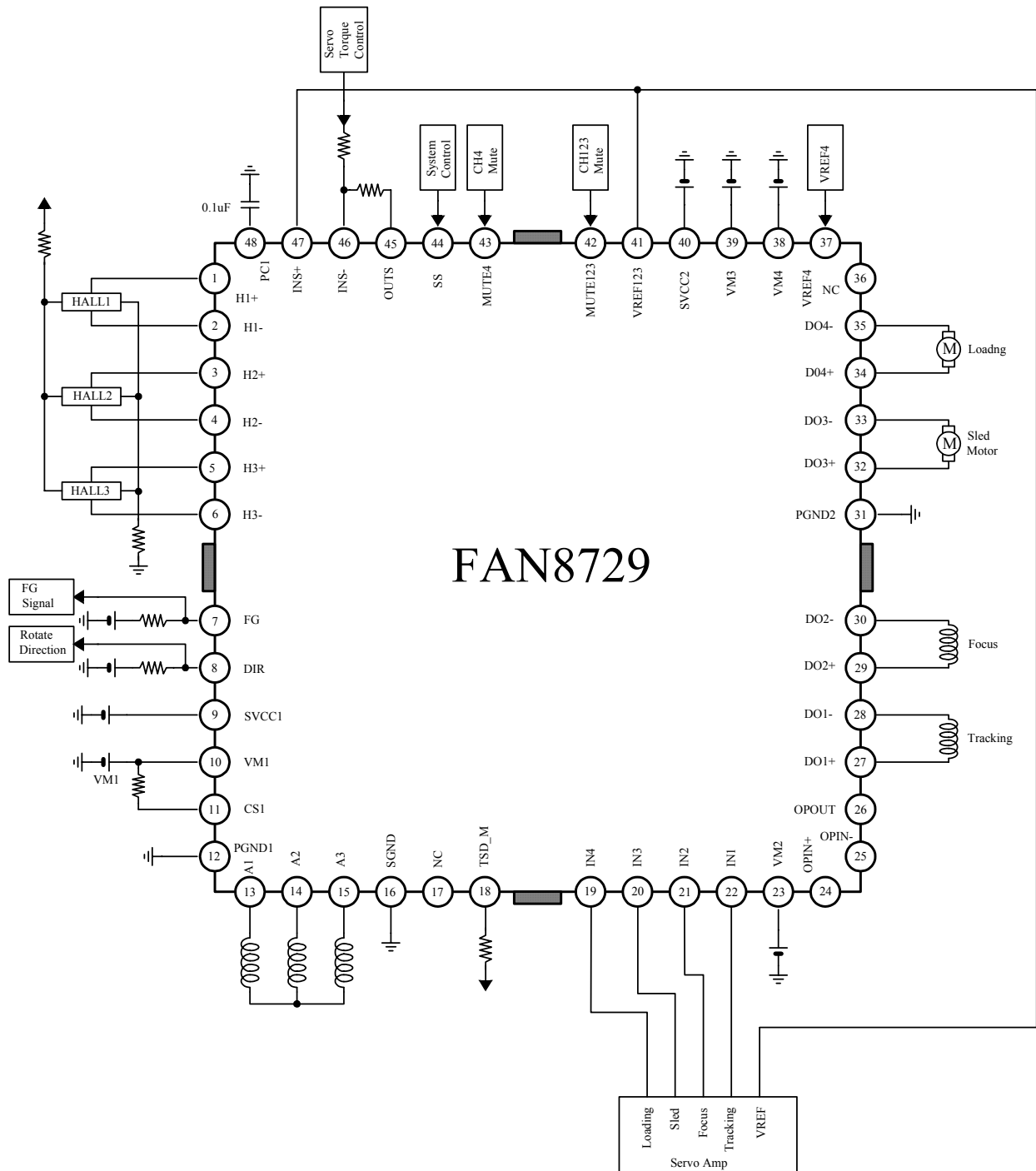

Notes:

Radiation pin is connected to the internal GND of the package.

Package Dimensions

48-QFPH-1414

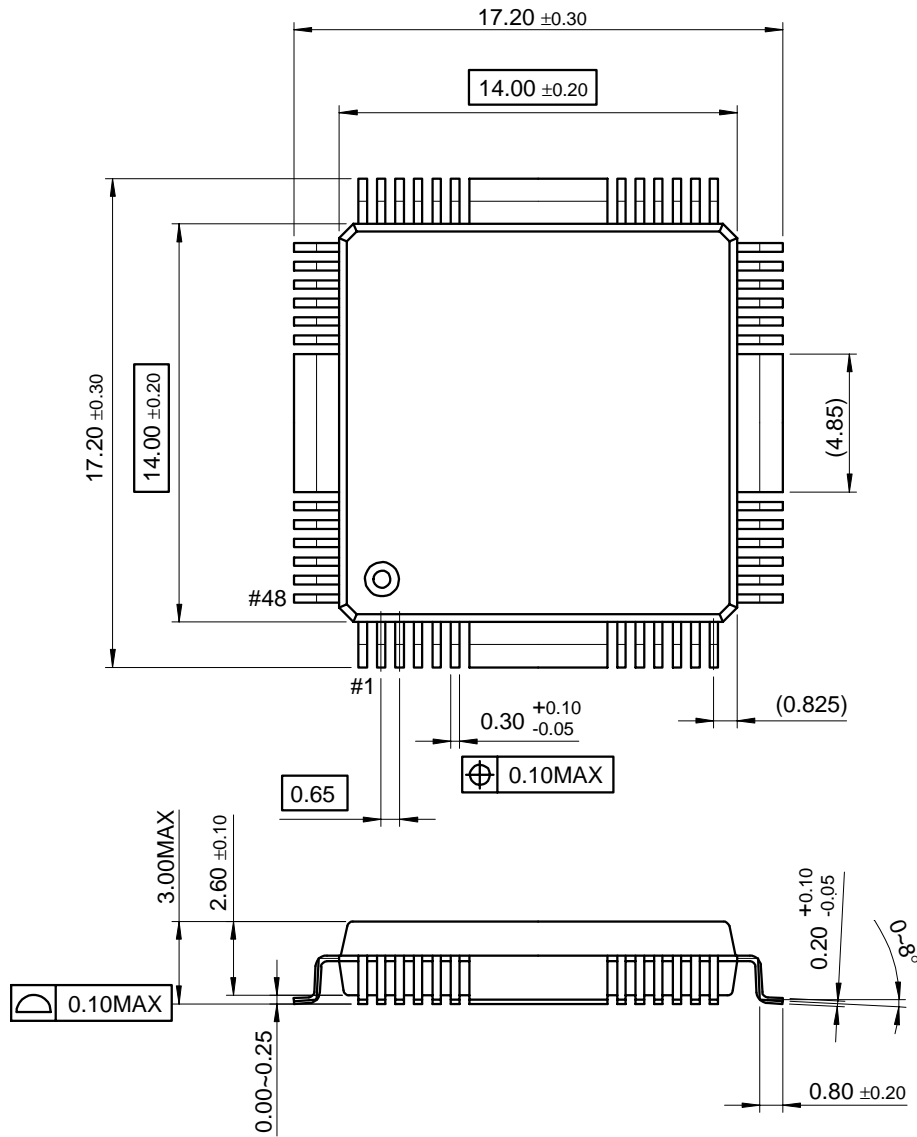

DISCLAIMER

FAIRCHILD SEMICONDUCTOR RESERVES THE RIGHT TO MAKE CHANGES WITHOUT FURTHER NOTICE TO ANY PRODUCTS HEREIN TO IMPROVE RELIABILITY, FUNCTION OR DESIGN. FAIRCHILD DOES NOT ASSUME ANY LIABILITY ARISING OUT OF THE APPLICATION OR USE OF ANY PRODUCT OR CIRCUIT DESCRIBED HEREIN; NEITHER DOES IT CONVEY ANY LICENSE UNDER ITS PATENT RIGHTS, NOR THE RIGHTS OF OTHERS.

LIFE SUPPORT POLICY

FAIRCHILD'S PRODUCTS ARE NOT AUTHORIZED FOR USE AS CRITICAL COMPONENTS IN LIFE SUPPORT DEVICES OR SYSTEMS WITHOUT THE EXPRESS WRITTEN APPROVAL OF THE PRESIDENT OF FAIRCHILD SEMICONDUCTOR CORPORATION. As used herein:

1. Life support devices or systems are devices or systems which, (a) are intended for surgical implant into the body, or (b) support or sustain life, and (c) whose failure to perform when properly used in accordance with instructions for use provided in the labeling, can be reasonably expected to result in a significant injury of the user.
2. A critical component in any component of a life support device or system whose failure to perform can be reasonably expected to cause the failure of the life support device or system, or to affect its safety or effectiveness.