

Operating Guide

FPA Evaluation Board

- DC-DC Converter Chip Set
- Up to 100 A output
- Easy to use
- Features Adaptive Loop feedback

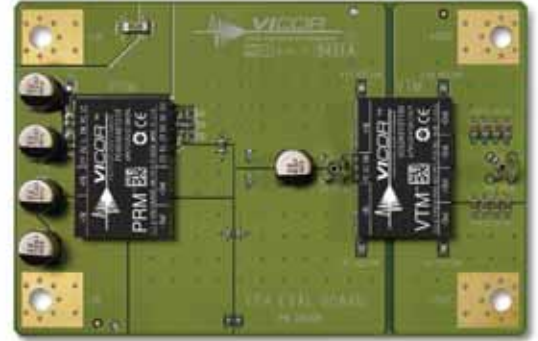

Please read this document before applying input voltage to the Evaluation Board.

Factorized Power Architecture (FPA) offers a fundamentally new and improved approach to distributed power.* The FPA Evaluation Board described in this document is intended to acquaint you with some of the benefits and features of FPA, and it is not designed to be used or installed in “End Use” equipment.

The PRM / VTM Chip Set mounted on this Evaluation Board features a unique "Adaptive Loop" compensation feedback: a single-wire alternative to traditional remote sensing and feedback loops that enables precise control of an isolated Point-of-Load (POL) voltage without the need for either a direct connection to the POL or for noise sensitive, bandwidth limiting, isolation devices in the feedback path.

DC-DC Converter Implementation

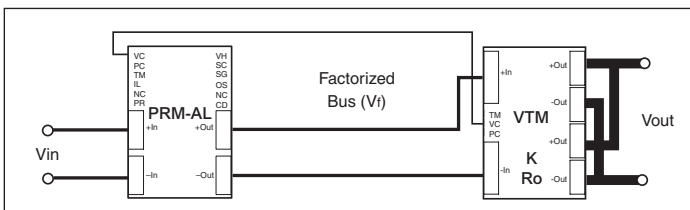

Figure 1 — The P048F048T24AL PRM is used with any 048 input series VTM to provide a regulated and isolated output.

In operation, V•I Chips can operate safely at high temperatures. Use caution when connecting test probes and interface lines to avoid touching hot surfaces. Be sure the power is off before making or breaking connections to the Evaluation Board.

* Refer to Vicor document “DC-DC Converter Chip Set Overview” for a description of FPA and an overview of its essential elements.

Recommended Fastening Hardware:

QTY	Description	Manufacturer P/N	Vicor P/N
4	#6 AWG Ring Lug	PANDUIT LCAS6-10-L	
4	#10-32 Screw	} Kit # 26647	
4	#10 Flat Washer		
4	#10 Lock Washer		
4	#10 Hex Nut		

All hardware is Stainless Steel except Ring Lugs.
Kit # 26647 is not included with Evaluation Board.

Test Procedure

1.0 Recommended Equipment

- 1.1 DC Power supply – 0-100 V; 500 W; 10 A
- 1.2 DC Electronic load – Pulse capable; 0-100 V; 100 A
- 1.3 DMM
- 1.4 Oscilloscope
- 1.5 Interconnect cables (appropriately sized for current)
- 1.6 Fastening hardware
- 1.7 Fan
- 1.8 Safety glasses
- 1.9 Data sheets for the specific PRM and VTM models

2.0 Description of FPA Evaluation Board Components and Features

(Refer to Figure 2 or 3 for item location)

- | | | |
|------|-------------|--|
| 2.1 | +IN and -IN | Source voltage connection terminals |
| 2.2 | PC/TP1 | Enable / disable connection terminal |
| 2.3 | IL | Resistor R1 for adjusting current limit |
| 2.4 | SC | Capacitor C5 for adjusting soft start |
| 2.5 | OS | Output voltage set resistor R4 |
| 2.6 | CD | Compensation device resistor R6 |
| 2.7 | C6 | Optional Vf capacitor |
| 2.8 | J1 | Vf VIEW oscilloscope jack |
| 2.9 | TP2/TP4 | +/- VTM input Kelvin connection test points |
| 2.10 | TP3/TP5 | +/- VTM output Kelvin connection test points |
| 2.11 | J2 | Vo VIEW output voltage oscilloscope jack |
| 2.12 | +OUT / -OUT | Load connection terminals |

Specifications

Part Numbering

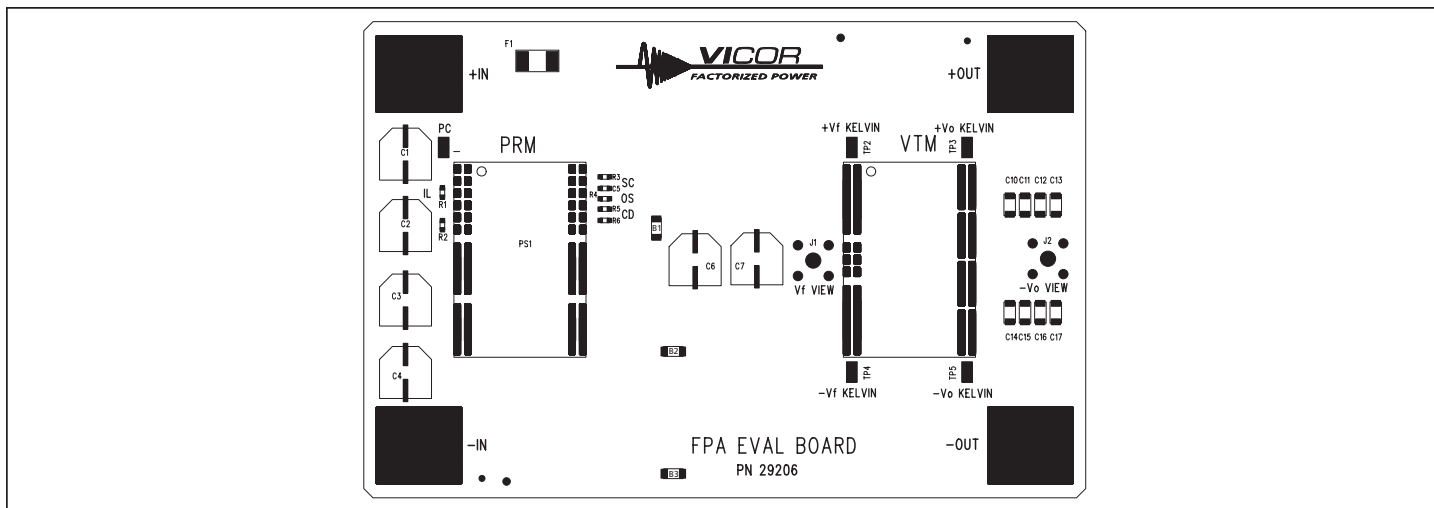
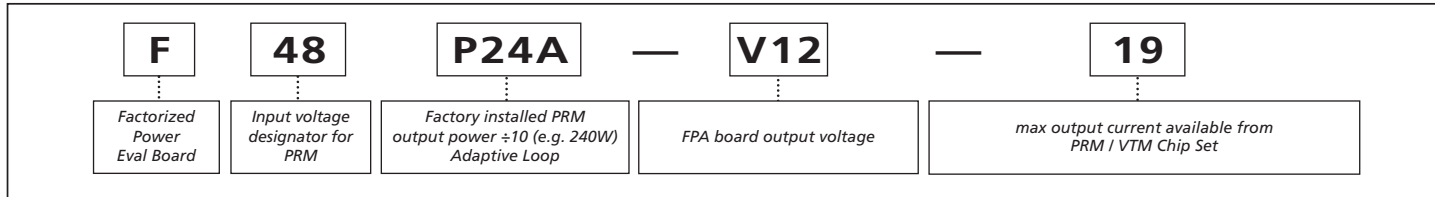

Figure 2 – EVAL Board Layout – Top side

3.0 Hook Up

An external power supply (1.1) should be used to provide power.

- 3.1 Connect Positive input lead to Eval Board +IN and external supply +Out.
- 3.2 Connect Negative input lead to Eval Board -IN and external supply -Out.

An external load (1.2) should be connected to the output terminals with leads and lugs having adequate current capacity.

- 3.4 Connect Positive output lead to Eval Board +OUT and external load +In.
- 3.5 Connect Negative output lead to Eval Board -OUT and external load -In.

!! As the output current of the Eval Board can achieve 100 Amperes, connections must be tight and properly sized in order to minimize losses due to contact resistance !!

4.0 Verify Connections

5.0 Test Sequence

- 5.1 Assure DC supply is set to 0 Vdc prior to turning unit on and set supply current to 8 A minimum.
- 5.2 Turn on DC supply.
- 5.3 Make sure DC load is set to 0 A prior to turning on load.
- 5.4 Turn on DC load.
- 5.5 Connect DMM or scope probe to the test points provided to monitor output voltage (Vout). Vf View and Vo View (J1 and J2) are provided to make accurate measurements of the Factorized Bus (Vf) and Vout.

Various types of scope probes may be directly connected to these points if the probe is equipped with a removable plastic sheath. Be careful to avoid creating ground loops when making measurements of Vf and Vin.

It is recommended that these measurements be made separately since shorting -IN to -OUT of the PRM disables current limit.

- 5.6 Turn-on fan (Use of an external fan is recommended.)
- 5.7 Slowly raise the DC input voltage to 48 Vdc (Output voltage should be present at 36 Vdc input).
- 5.8 Verify no load operation by raising and lowering the input voltage through the entire 36 – 75 Vdc range. Output voltage should remain constant.
- 5.9 Re-establish 48 Vdc input.
- 5.10 Slowly increase the load current to full load while monitoring the output voltage. The output voltage should remain within the limits specified in the appropriate PRM / VTM data sheets.
- 5.11 Return the load current to 0 A and decrease the input voltage to 36 Vdc.
- 5.12 Repeat step 5.10 – depending upon the external supply source and the source impedance it may be necessary to adjust the supply’s voltage to keep the input voltage to the PRM at 36 Vdc.
- 5.13 Return the load current to 0 A and increase the input voltage to 75 Vdc.
- 5.14 Repeat step 5.10

Specifications cont.

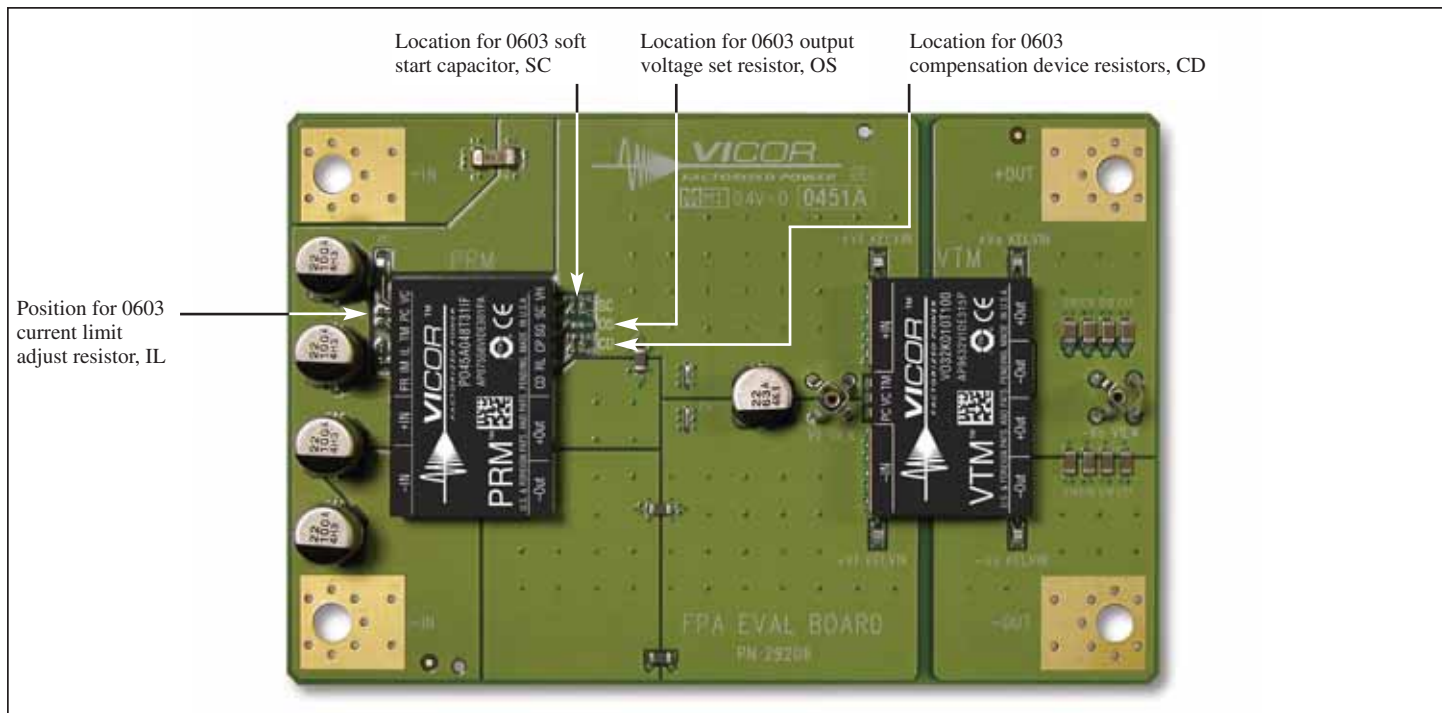

Figure 3 – FPA EVAL Board configuration may vary

The functionality of the FPA Eval Board has now been verified over the entire line and load operating range.

As you can see, the PRM’s Adaptive Loop regulates the output of the VTM without sense lines. You may monitor the Vf View (J1) while increasing the load current: the Vf voltage increases with the load current, compensating for the insertion loss due to the VTM output resistance.

Connecting the PRM’s PC (TP1) to the -IN disables the output of the Evaluation Board. Use CAUTION when probing, especially on or near TP1 and VC on the PRM. Accidental shorting between these two points can cause permanent damage.

The Evaluation Board has provisions for changing the factory set output voltage, the current limit, the Adaptive Loop Gain, and the turn on ramp rate. Refer to the PRM data sheet for more information on these features. Refer to Figure 4 for a Schematic representation of the FPA Evaluation Board. Locations for these components are shown in Figure 3.

For assistance, feel free to contact Vicor Applications Engineering at 800-927-9474

This Evaluation Board is being provided as a means to facilitate successful demonstration of Factorized Power Architecture and its elements. Vicor assumes no obligation or liability for the advice given, or results obtained. All such advice being given and accepted is at user’s risk.

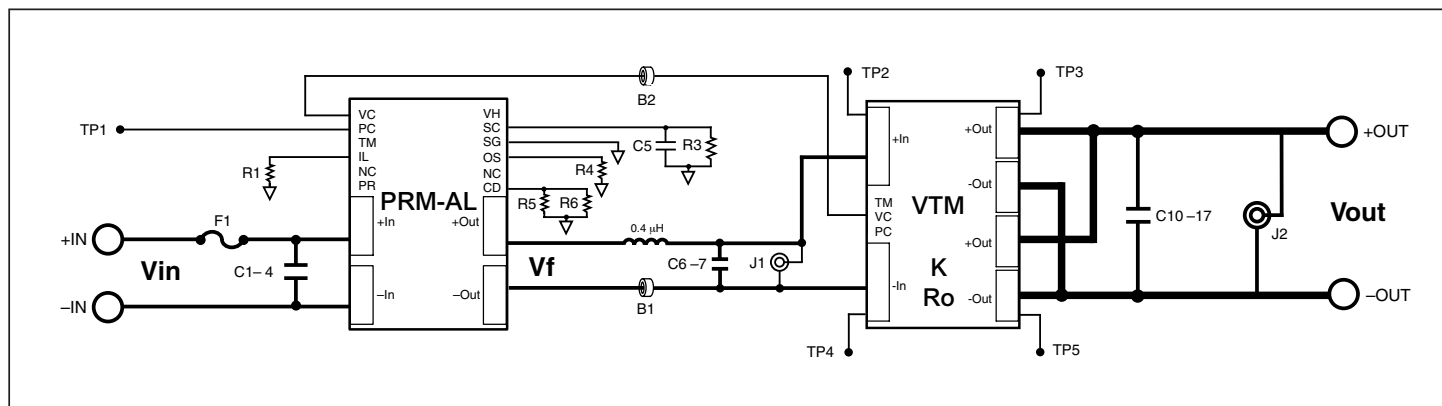

Figure 4 – EVAL Board Schematic Diagram

Warranty

Vicor products are guaranteed for two years from date of shipment against defects in material or workmanship when in normal use and service. This warranty does not extend to products subjected to misuse, accident, or improper application or maintenance. Vicor shall not be liable for collateral or consequential damage. This warranty is extended to the original purchaser only.

EXCEPT FOR THE FOREGOING EXPRESS WARRANTY, VICOR MAKES NO WARRANTY, EXPRESS OR IMPLIED, INCLUDING, BUT NOT LIMITED TO, THE WARRANTY OF MERCHANTABILITY OR FITNESS FOR A PARTICULAR PURPOSE.

Vicor will repair or replace defective products in accordance with its own best judgement. For service under this warranty, the buyer must contact Vicor to obtain a Return Material Authorization (RMA) number and shipping instructions. Products returned without prior authorization will be returned to the buyer. The buyer will pay all charges incurred in returning the product to the factory. Vicor will pay all reshipment charges if the product was defective within the terms of this warranty.

Information published by Vicor has been carefully checked and is believed to be accurate; however, no responsibility is assumed for inaccuracies. Vicor reserves the right to make changes to any products without further notice to improve reliability, function, or design. Vicor does not assume any liability arising out of the application or use of any product or circuit; neither does it convey any license under its patent rights nor the rights of others. Vicor general policy does not recommend the use of its components in life support applications wherein a failure or malfunction may directly threaten life or injury. Per Vicor Terms and Conditions of Sale, the user of Vicor components in life support applications assumes all risks of such use and indemnifies Vicor against all damages.

Vicor's comprehensive line of power solutions includes high density AC-DC and DC-DC modules and accessory components, fully configurable AC-DC and DC-DC power supplies, and complete custom power systems.

Information furnished by Vicor is believed to be accurate and reliable. However, no responsibility is assumed by Vicor for its use. Vicor components are not designed to be used in applications, such as life support systems, wherein a failure or malfunction could result in injury or death. All sales are subject to Vicor's Terms and Conditions of Sale, which are available upon request.

Specifications are subject to change without notice.

Intellectual Property Notice

Vicor and its subsidiaries own Intellectual Property (including issued U.S. and Foreign Patents and pending patent applications) relating to the products described in this data sheet. Interested parties should contact Vicor's Intellectual Property Department.

Vicor Corporation

25 Frontage Road
Andover, MA, USA 01810
Tel: 800-735-6200
Fax: 978-475-6715

email

Vicor Express: vicorexp@vicr.com
Technical Support: apps@vicr.com