

10/100Base-TX Interface Module for PC Card Applications

EPF8064SM

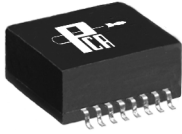

- Recommended for use with SSI 78Q2120 chips
- Low profile, fully integrated with two channels
- Guaranteed to operate with 8 mA DC bias at 70°C
- Complies with or exceeds IEEE 802.3, 10/100Base-TX Standards

Electrical Parameters @ 25° C

OCL (@ 70°C)	Insertion Loss (dB Max.)			Return Loss (dB Min.)			Common Mode Rejection (dB Min.)			Crosstalk (dB Min.) Between Channels	
	1-80 MHz	100 MHz	150 MHz	30 MHz	60 MHz	100 MHz	1-30 MHz	100 MHz	500 MHz	1-10 MHz	100 MHz
100 KHz, 0.1 Vrms 8 mA DC Bias											
Cable Side	Xmit/Rcv	Xmit/Rcv	Xmit/Rcv	Xmit/Rcv	Xmit/Rcv	Xmit/Rcv	Xmit/Rcv	Xmit/Rcv	Xmit/Rcv		
350 μ H	-1/-1	-1/-1	-3.5/-3.5	-18/-18	-12/-12	-10/-10	-30/-30	-25/-25	-10/-10	-40	-40

• Isolation : 1500 Vrms • Impedance : 100 Ω • Rise Time : 3.0 nS Max. •

Schematic

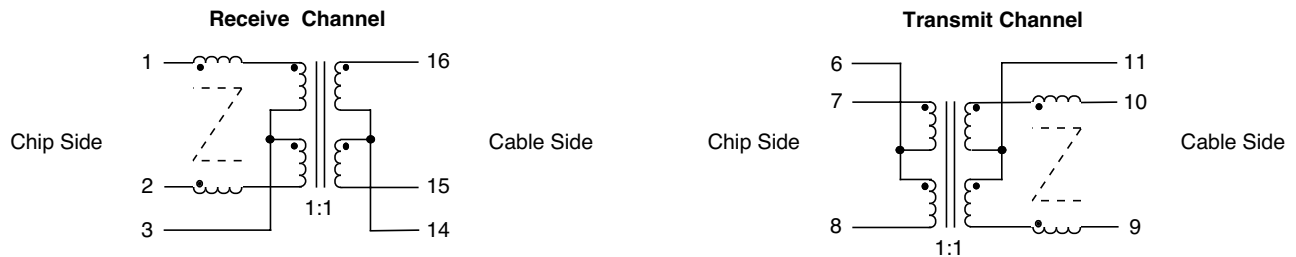

Package

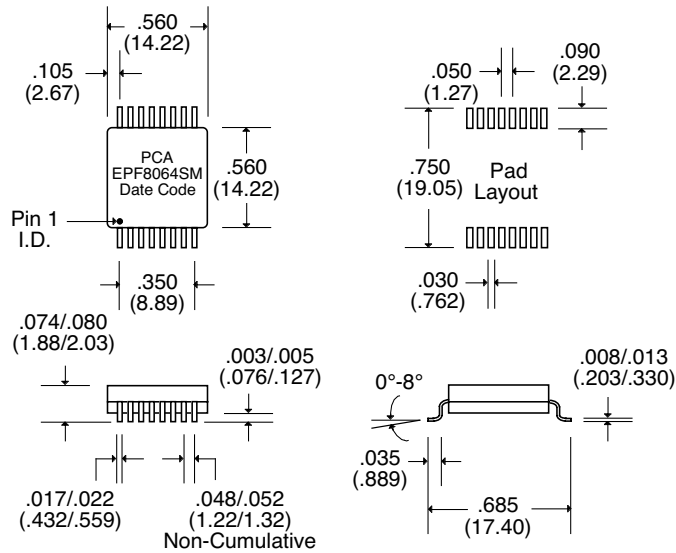

Coplanarity within .003 Max.

Unless Otherwise Specified Dimensions are in Inches /mm \pm .010 / .25