

**10A 30V Cathode Common**

**SBD** Type : **ECQ10A03L**

OUTLINE DRAWING

For High Frequency Rectification

**FEATURES**

- \* Dpak package
- \* Dual Diodes Cathode Common
- \* Low Forward Voltage Drop and Low Noise

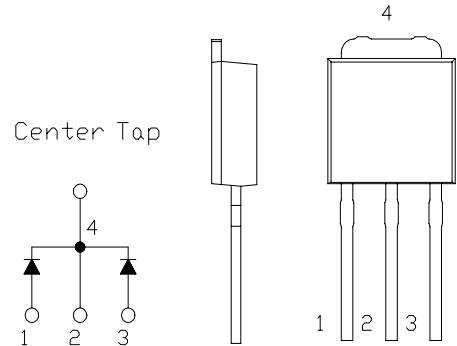

**Maximum Ratings**

Approx Net Weight:0.35g

Rating	Symbol	ECQ10A03L			Unit
Repetitive Peak Reverse Voltage	$V_{RRM}$	30			V
Average Rectified Output Current	$I_o$	10	$T_c=106^{\circ}C$	50 Hz, Full Sine Wave Resistive Load	A
		2.0	$T_a=30^{\circ}C$	50 Hz, Full Sine Wave Resistive Load P.C.Board mounted *	
RMS Forward Current	$I_{F(RMS)}$	11.1			A
Surge Forward Current	$I_{FSM}$	100	50 Hz Full Sine Wave, 1cycle Non-repetitive		A
Operating Junction Temperature Range	$T_{jw}$	- 40 to + 150			$^{\circ}C$
Storage Temperature Range	$T_{stg}$	- 40 to + 150			$^{\circ}C$

**Electrical • Thermal Characteristics**

Characteristics	Symbol	Conditions	Min.	Typ.	Max.	Unit
Peak Reverse Current	$I_{RM}$	$T_j=25^{\circ}C, V_{RM}=V_{RRM}$ per Diode	-	-	5	mA
Peak Forward Voltage	$V_{FM}$	$T_j=25^{\circ}C, I_{FM}=5A$ per Diode	-	-	0.47	V
Thermal Resistance	$R_{th(j-c)}$	Junction to Case	-	-	4	$^{\circ}C/W$
	$R_{th(j-a)}$	Junction to Ambient With P.C.Board mounted *	-	-	80	

\*: Print Land 20x20

ECQ10A03L OUTLINE DRAWING (Dimensions in mm)

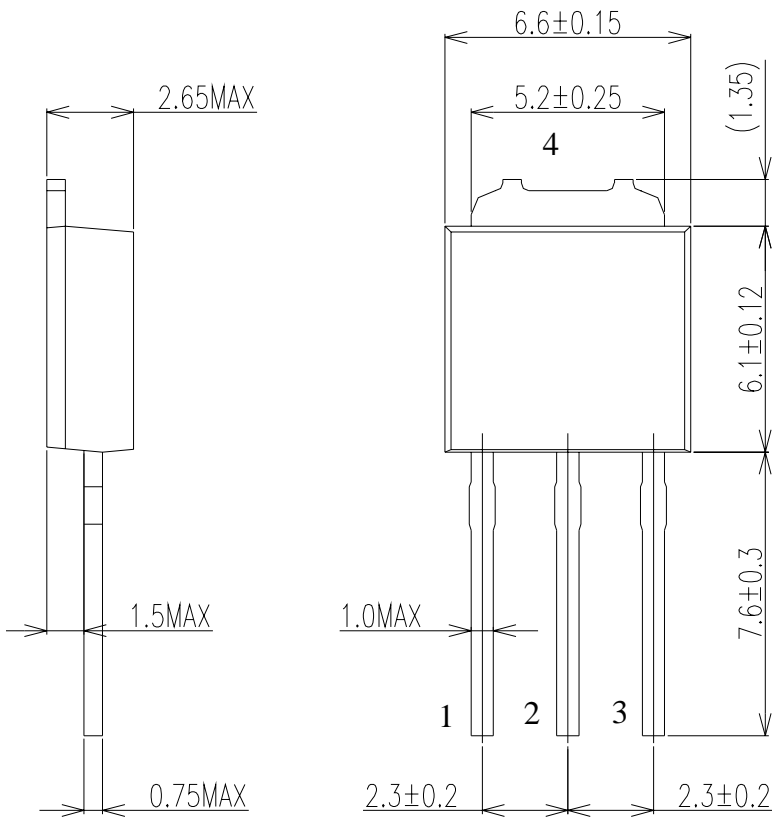

Center Tap

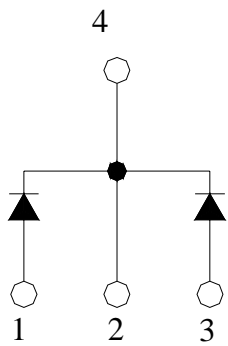

### FORWARD CURRENT VS. VOLTAGE

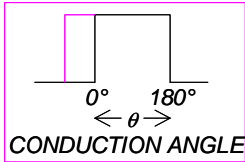
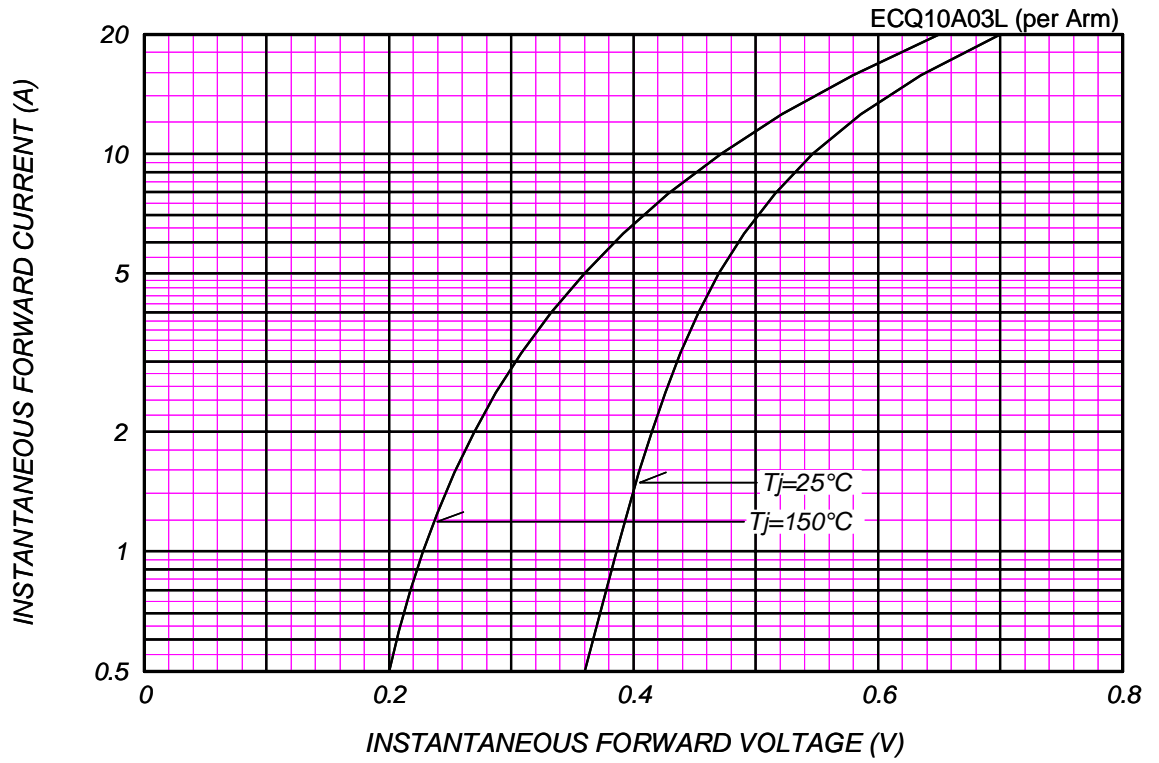

### AVERAGE FORWARD POWER DISSIPATION

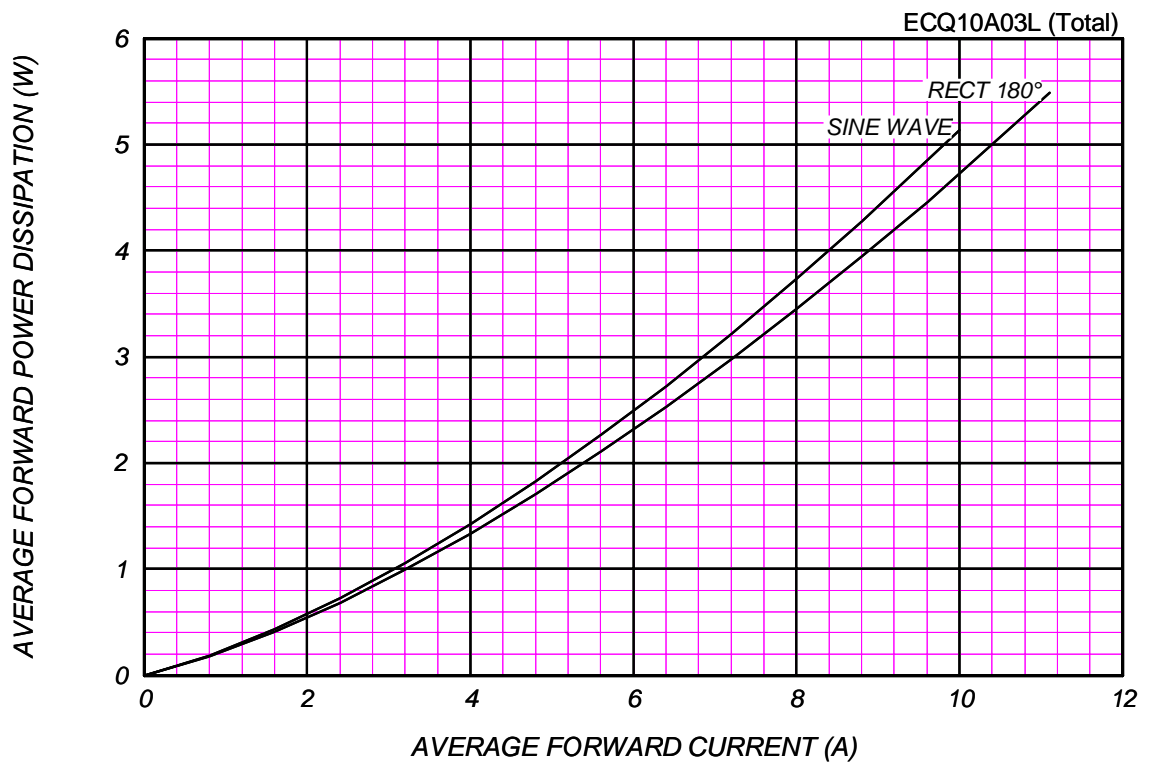

PEAK REVERSE CURRENT VS. PEAK REVERSE VOLTAGE

T<sub>j</sub> = 150 °C

ECQ10A03L (per Arm)

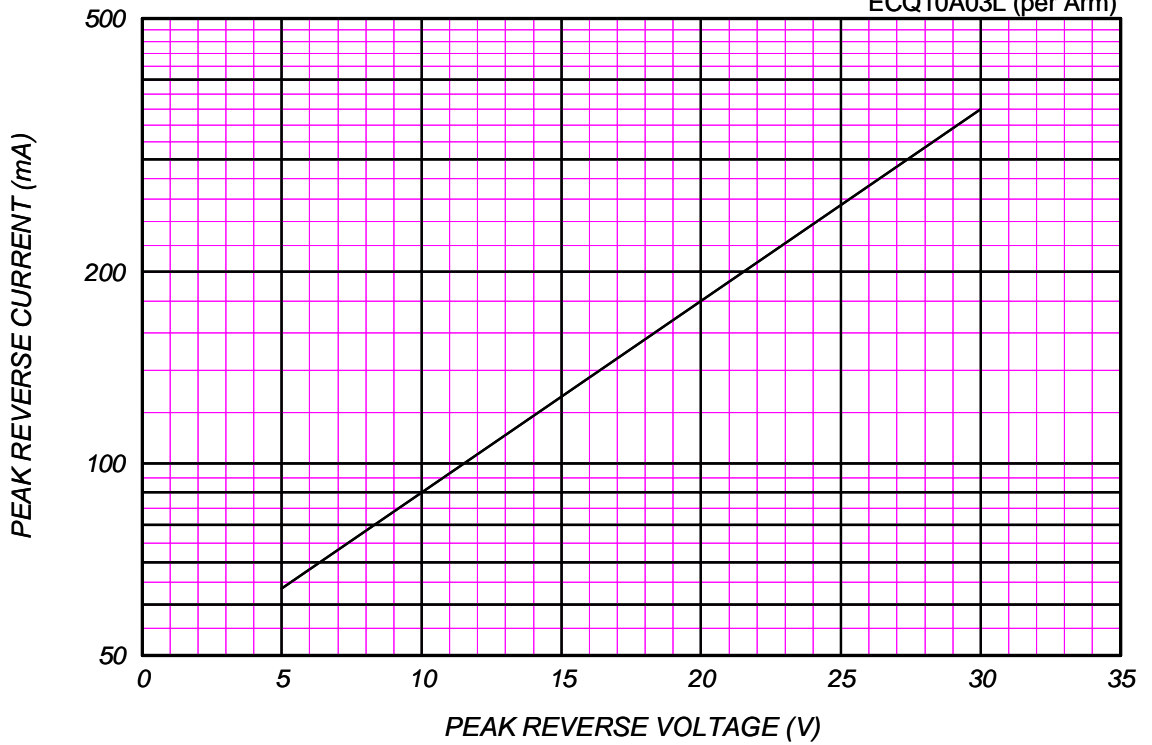

AVERAGE REVERSE POWER DISSIPATION

ECQ10A03L (Total)

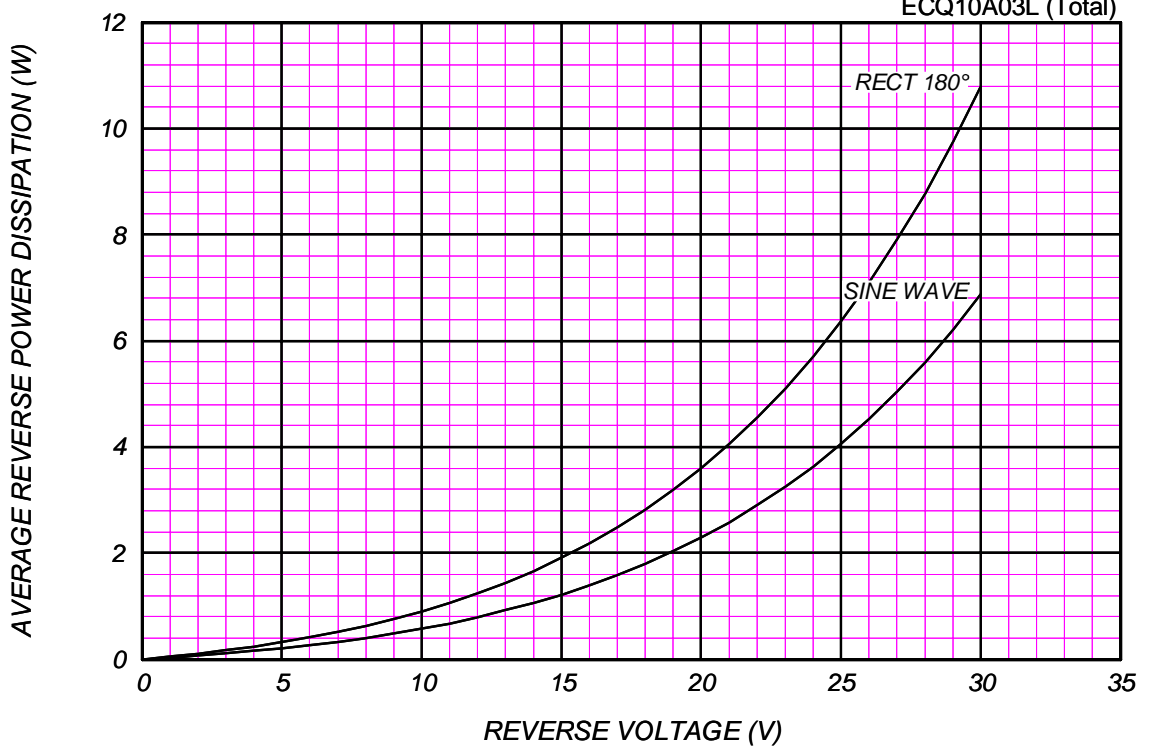

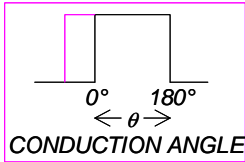

### AVERAGE FORWARD CURRENT VS. CASE TEMPERATURE

$V_{RM}=30V$

ECQ10A03L (Total)

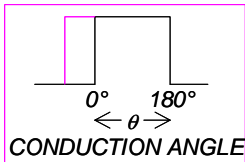
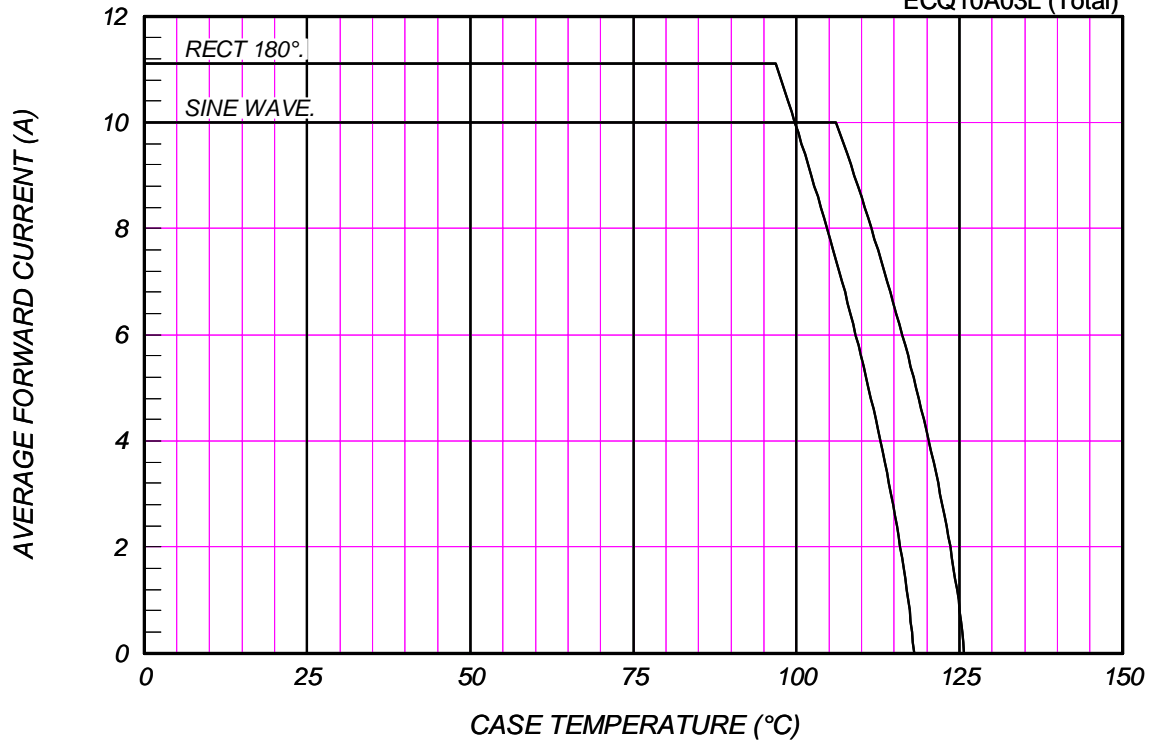

### AVERAGE FORWARD CURRENT VS. AMBIENT TEMPERATURE

$V_{RM}=30V$

ECQ10A03L (Total)

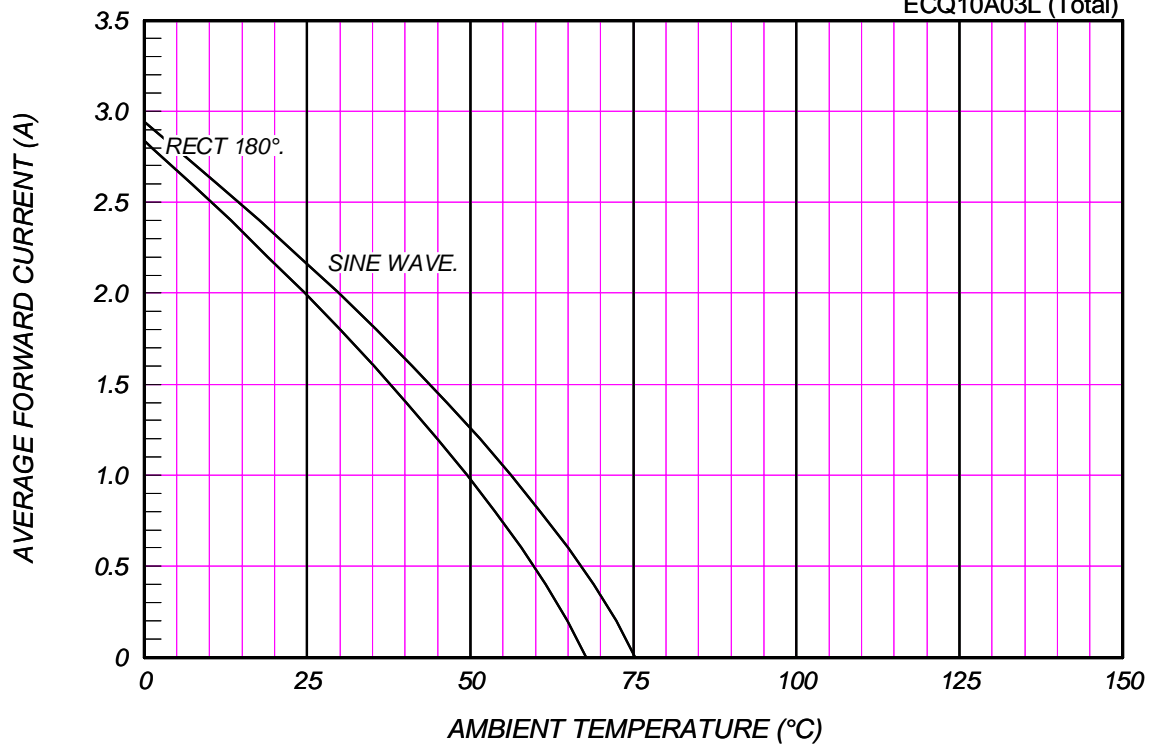

### SURGE CURRENT RATINGS

f=50Hz,Sine Wave,Non-Repetitive,No Load

ECQ10A03L

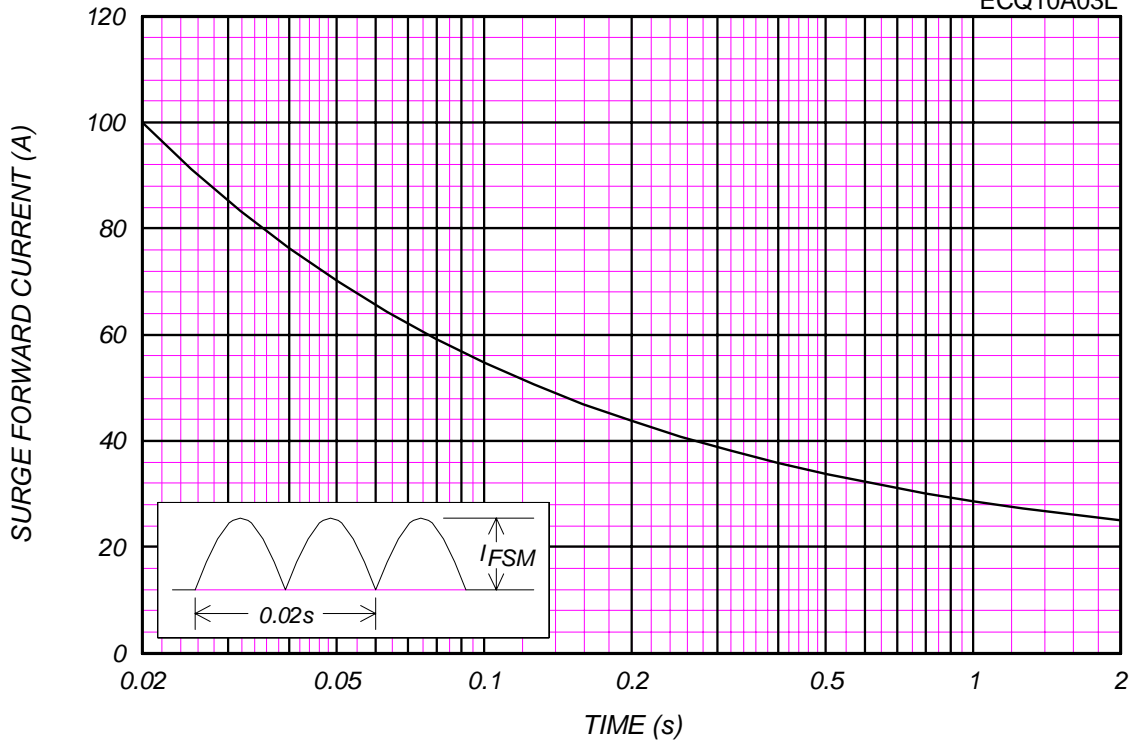

### JUNCTION CAPACITANCE VS. REVERSE VOLTAGE

T<sub>j</sub>=25°C,V<sub>m</sub>=20mV<sub>RMS</sub>,f=100kHz,Typical Value

ECQ10A03L (per Arm)

