

DIODE MODULE

DWF(R)70BB30/40

Power Diode Module **DWF(W)70BB** is designed for three phase half wave rectification, which has three diodes connected in a three phase bridge configuration. The mounting base of the module is electrically isolated from semiconductor elements for simple heatsink construction. Output DC current is 70Amp ($T_c=106^\circ\text{C}$) Repetitive peak reverse voltage is up to 400V.

- $T_{j\text{Max}}=150^\circ\text{C}$
- Isolated mounting Base
- High reliability by unique glass passivation

(Applications)

AC, DC Motor Drive/AVR/Switching
-for three phase rectification

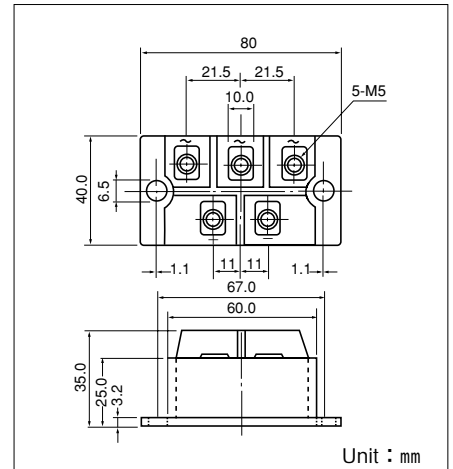
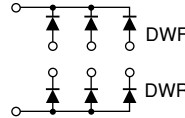

Maximum Ratings

($T_j=25^\circ\text{C}$ unless otherwise specified)

Symbol	Item	Ratings		Unit
		DWF(R)70BB30	DWF(R)70BB40	
V_{RRM}	Repetitive Peak Reverse Voltage	300	400	V
V_{RSM}	Non-Repetitive Peak Reverse Voltage	360	480	V

Symbol	Item	Conditions	Ratings	Unit	
I_D	Average Forward Current (D.C.)	D.C. $T_c : 106^\circ\text{C}$	70	A	
I_{FSM}	Surge Forward Current	1cycle, 60Hz, peak value, non-repetitive	1400	A	
I^2t	I^2t	Value for one cycle of surge current	8100	A^2S	
T_j	Operating Junction Temperature		-40 to +150	$^\circ\text{C}$	
T_{stg}	Storage Temperature		-40 to +125	$^\circ\text{C}$	
V_{ISO}	Isolation Breakdown Voltage (R.M.S.)	A.C. 1minute	2500	V	
	Mounting Torque	Mounting (M5)	Recommended Value 1.5-2.5 (15-25)	2.7 (28)	N·m (kgf·cm)
		Terminal (M5)	Recommended Value 1.5-2.5 (15-25)	2.7 (28)	
	Mass	Typical Value	200	g	

Electrical Characteristics

Symbol	Item	Conditions	Ratings			Unit
			Min.	Typ.	Max.	
I_{RRM}	Repetitive Peak Reverse Current	$T_j=150^\circ\text{C}$ at V_{RRM}			12	mA
V_{FM}	Forward Voltage Drop	$T_j=25^\circ\text{C}$, $I_{FM}=220\text{A}$, Inst. measurement			1.15	V
$R_{th(j-c)}$	Thermal Impedance	Junction to case ($\frac{1}{3}$ MODULE)			0.55	$^\circ\text{C}/\text{W}$

