

### Multi DomiLED<sup>™</sup>

Synonymous with function and performance, the Multi DomiLED<sup>™</sup> series is perfectly suited for a variety of cross-industrial applications due to its small package outline, durability and superior brightness.

### Features:

- > High brightness bi-color surface mount LED.
- > 120° viewing angle.
- > Small package outline (LxWxH) of 3.2 x 2.8 x 1.8mm.
- > Qualified according to JEDEC moisture sensitivity Level 2.
- > Compatible to both IR reflow soldering and TTW soldering.
- > Environmental friendly; RoHS compliance.

### Applications:

- > Automotive: interior applications, eg: switches, telematics, climate control system, dashboard, etc.
- > Consumer Appliances: LCD illumination as in PDAs, LCD TV.
- > Communication: indicator and backlight in mobilephone.
- > Display: full color display video notice board.
- > Industry: white goods (eg: Oven, microwave, etc.).

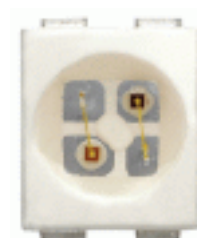

Part Ordering Number	Color, $\lambda_{dom}$ (nm)		Viewing Angle°	Luminous Intensity @ IF = 20mA IV (mcd)	
	Chip #1	Chip #2		Chip #1	Chip #2
<b>DMHG-GJS-NP+LM-1</b>	Hyper Red,	Green,	<b>120</b>	<b>28.5 - 71.5</b>	<b>11.2 - 28.5</b>
• DMHG-GJS-NL	645nm	570nm		28.5 - 45.0	11.2 - 18.0
• DMHG-GJS-NM				28.5 - 45.0	18.0 - 28.5
• DMHG-GJS-PL				45.0 - 71.5	11.2 - 18.0
• DMHG-GJS-PM				45.0 - 71.5	18.0 - 28.5

**NOTE**

1. DMXX comes in a quantity of 2000 units per reel.
2. Luminous intensity is measured with an accuracy of  $\pm 11\%$ .
4. Half group binning for luminous intensity is also available upon request.

**Wavelength Grouping**

Color	Group	Wavelength distribution (nm)
Hyper Red	Full	640 - 650
Green	Full	564.5 - 567.5
	W	564.5 - 567.5
	X	567.5 - 570.5
	Y	570.5 - 573.5
	Z	573.5 - 576.5

Dominant wavelength is measured with an accuracy of  $\pm 1$  nm.

**Electrical Characteristics at Ta=25°C**

	Vf @ If = 20mA	
	Typ. (V)	Max. (V)
Hyper Red	1.90	2.50
Green	2.20	2.50

Forward voltage, Vf is measured with an accuracy of ± 0.1 V.

**Absolute Maximum Ratings**

	Maximum Value	Unit
DC forward current	30	mA
Peak pulse current; (tp ≤ 10µs, Duty cycle = 0.005)	1000	mA
Reverse voltage	5	V
ESD Threshold (HBM)	2	kV
LED junction temperature	125	°C
Operating temperature	-55 ... +100	°C
Storage temperature	-55 ... +100	°C

**Relative Luminous Intensity Vs Forward Current**

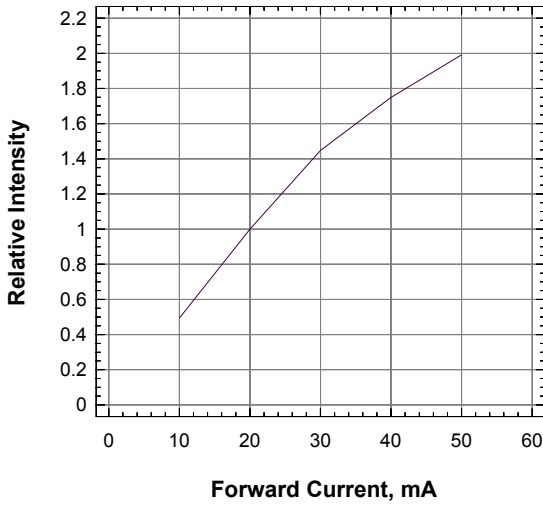

**Forward Current Vs Forward Voltage**

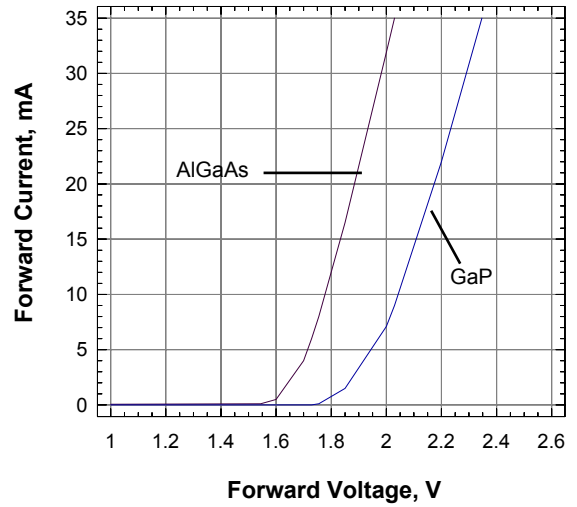

**Maximum Current Vs Temperature**

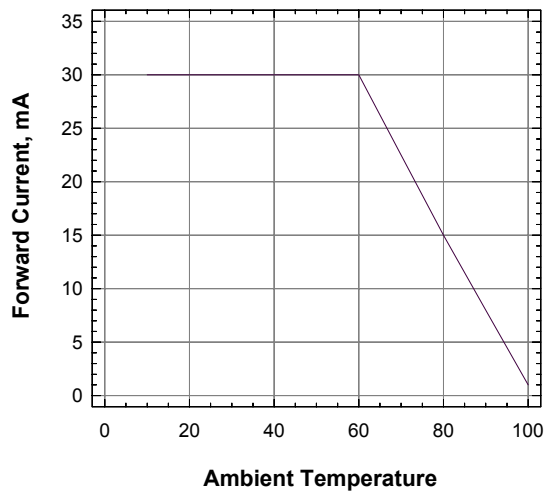

**Radiation Pattern**

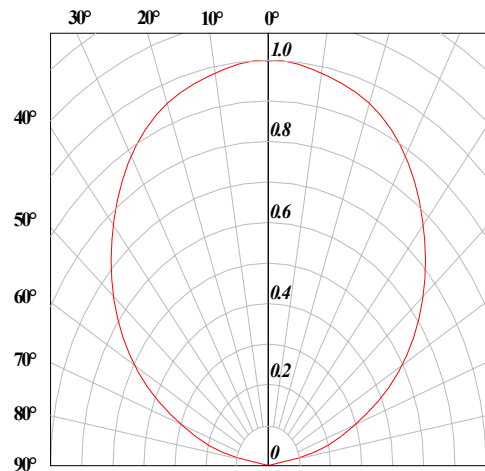

**Multi DomiLED™ • DMHG-GJ : Bi-Color Package Outlines**

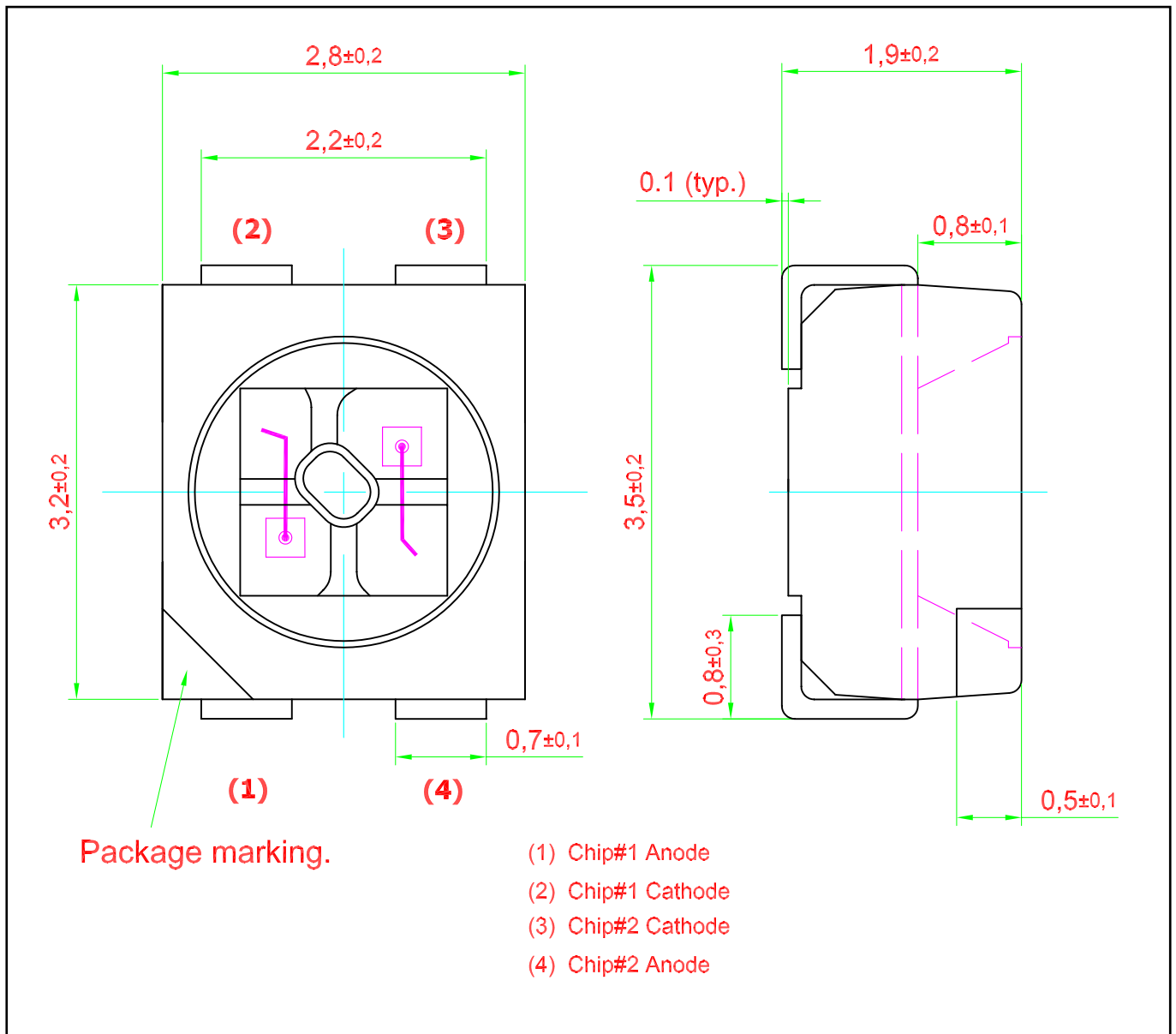

**Recommended Solder Pad**

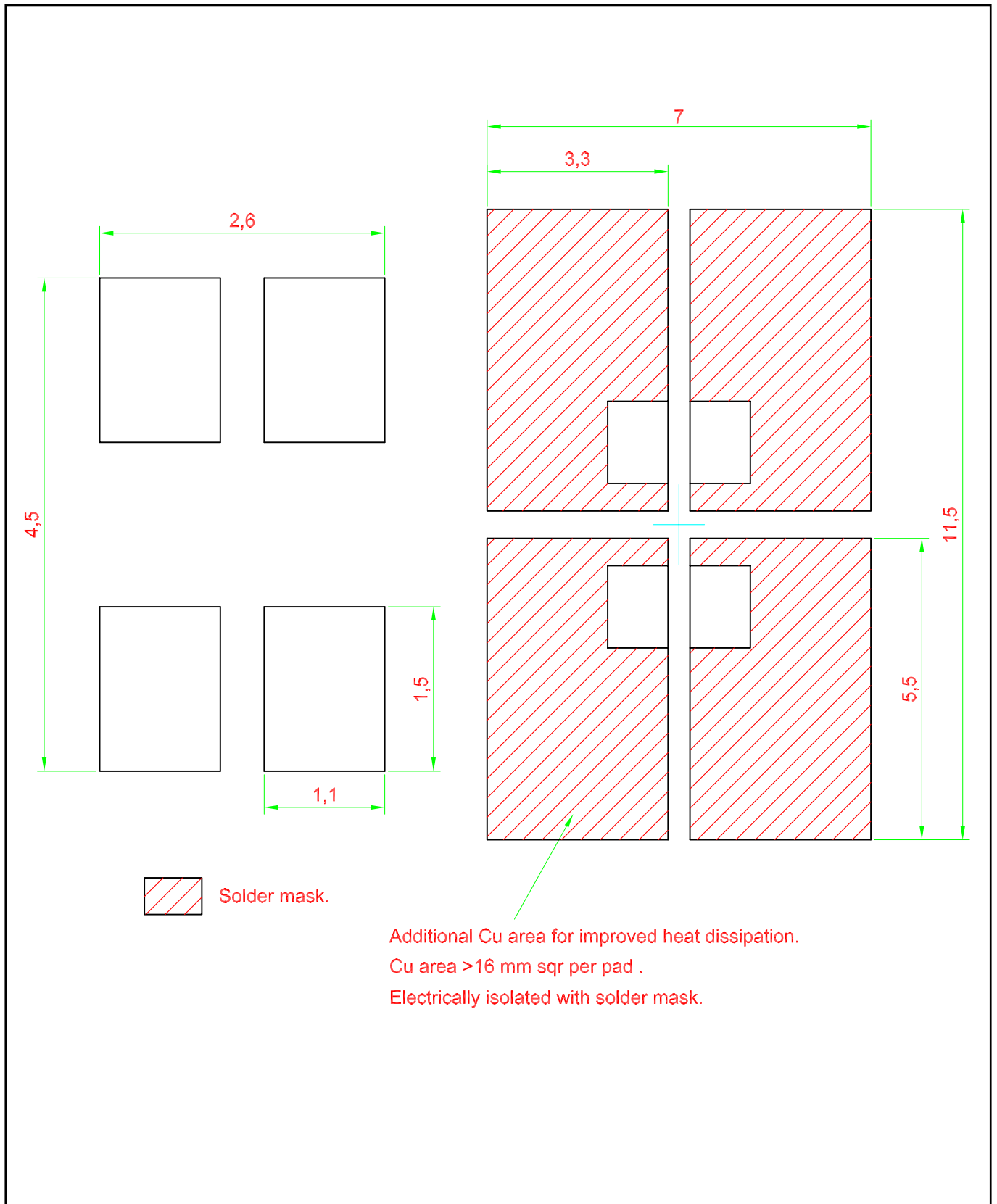

**Taping and orientation**

- Reels come in quantity of 2000 units.
- Reel diameter is 180 mm.

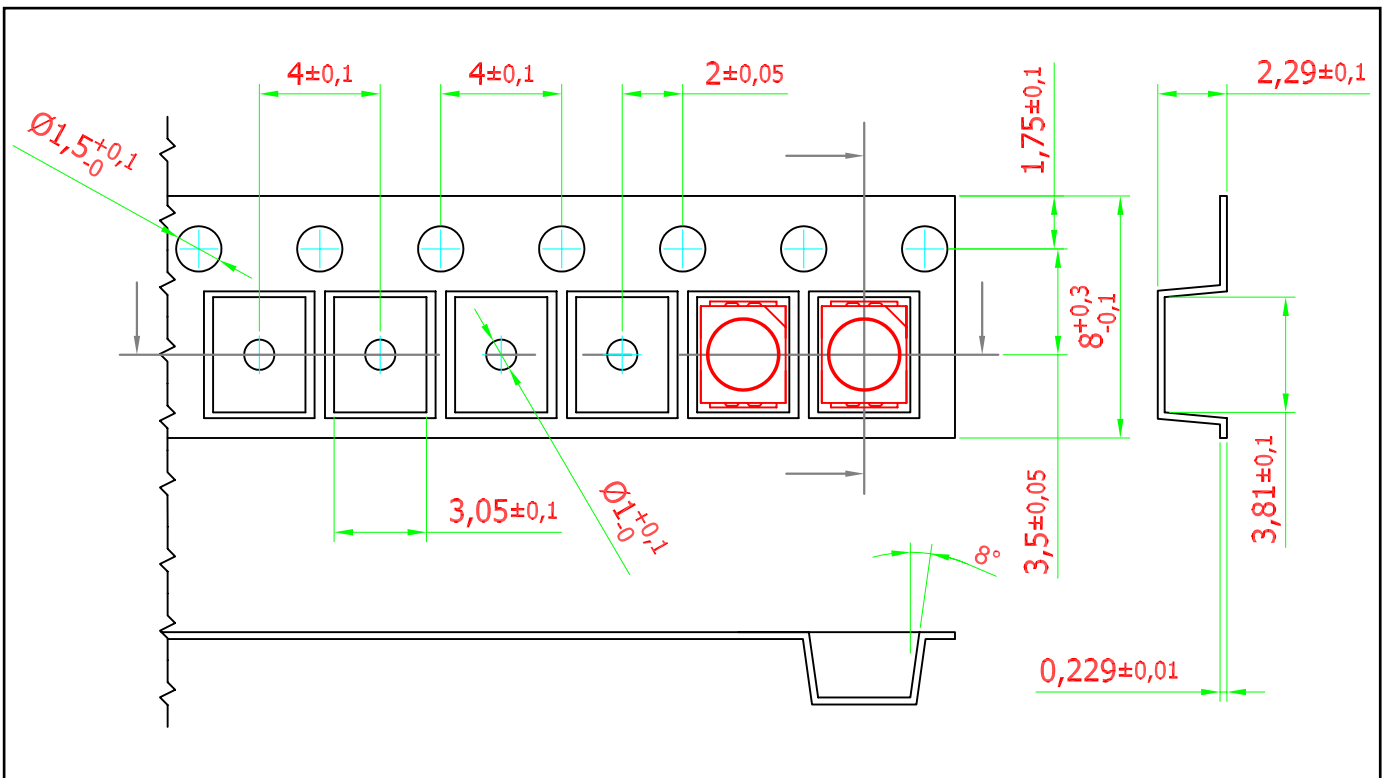

200 mm min. for  $\varnothing 180$  reel.  
200 mm min. for  $\varnothing 330$  reel.

480 mm min. for  $\varnothing 180$  reel.  
960 mm min. for  $\varnothing 330$  reel.

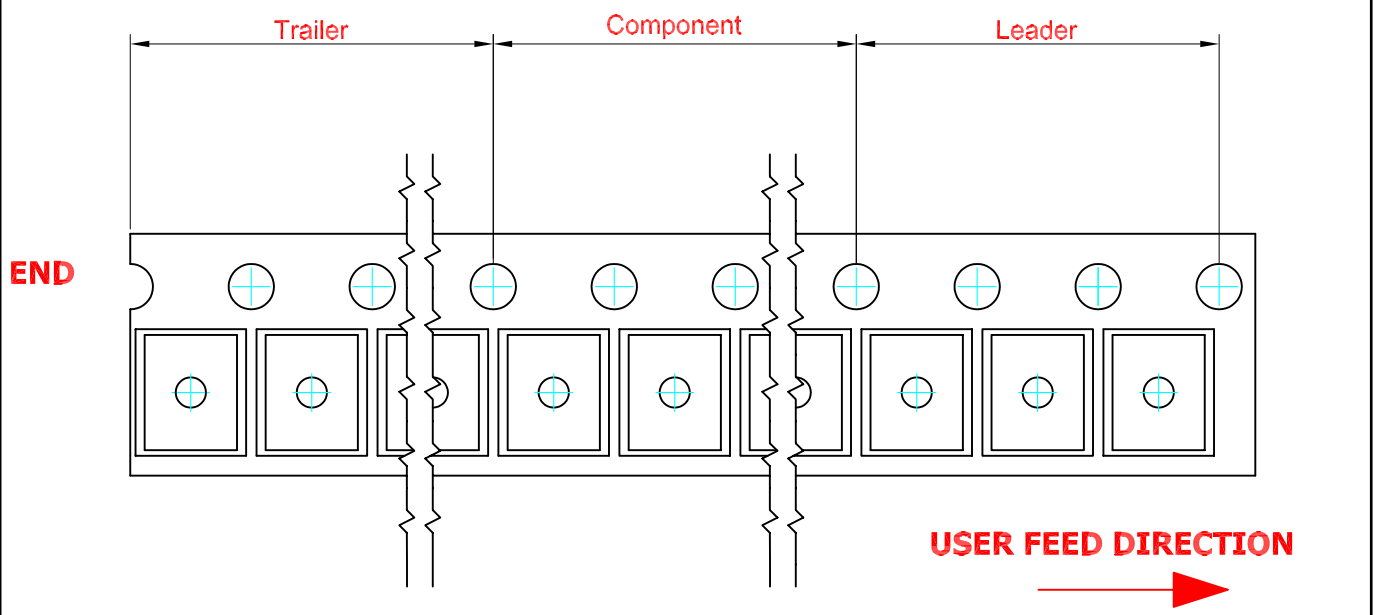

**Packaging Specification**

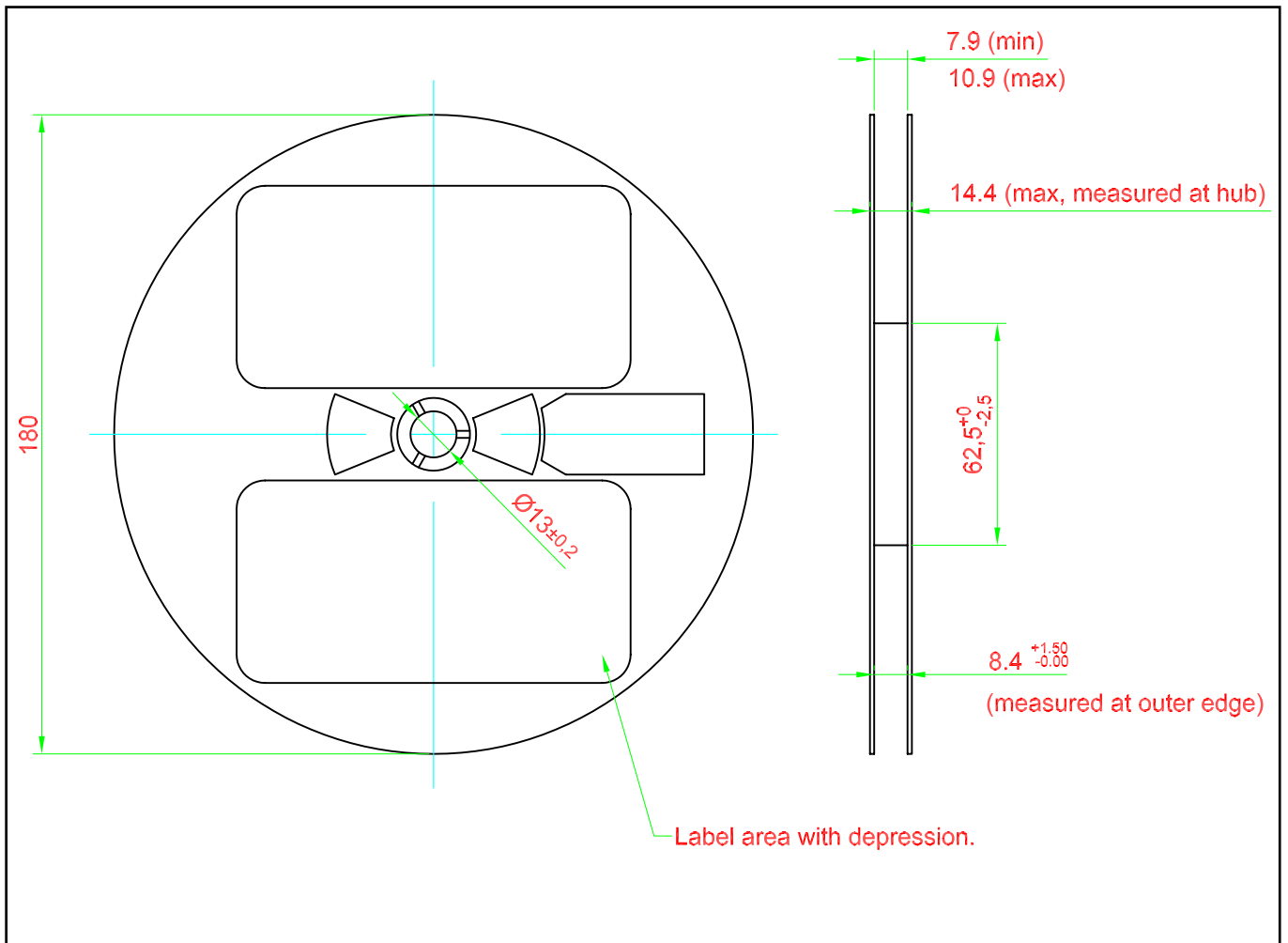



**Packaging Specification**

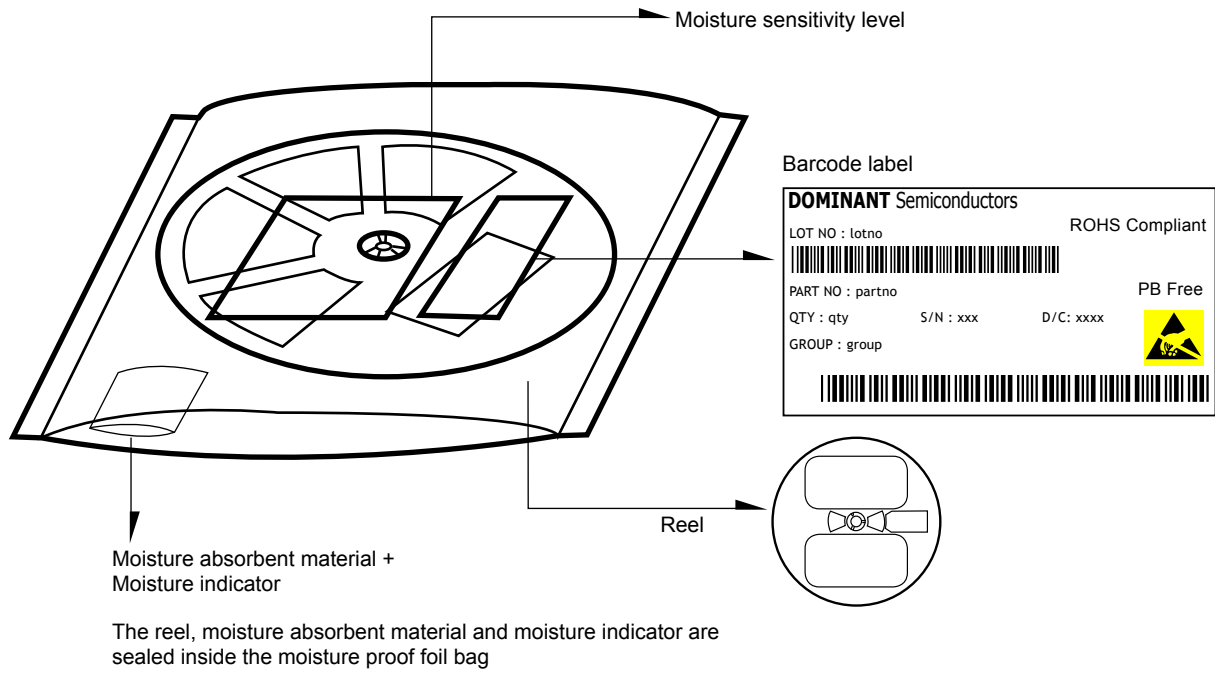

	Average 1pc DomiLED/Multi DomiLED	1 completed bag (2000pcs)
Weight (gram)	0.034	190 ± 10

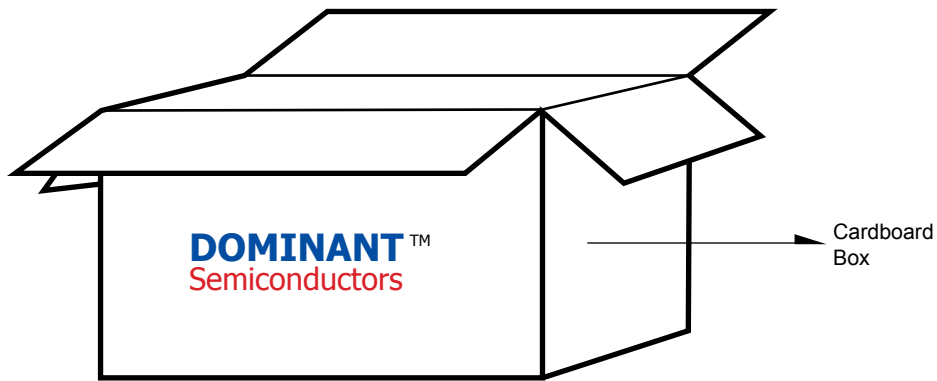

**For Multi DomiLED™**

Cardboard Box Size	Dimensions (mm)	Empty Box Weight (kg)	Reel / Box	Quantity / Box (pcs)
Small	300 x 250 x 250	0.58	15 reels MAX	30,000 MAX
Large	416 x 516 x 476	1.74	55 reels MAX	110,000 MAX

**Recommended Sn-Pb IR-Reflow Soldering Profile**

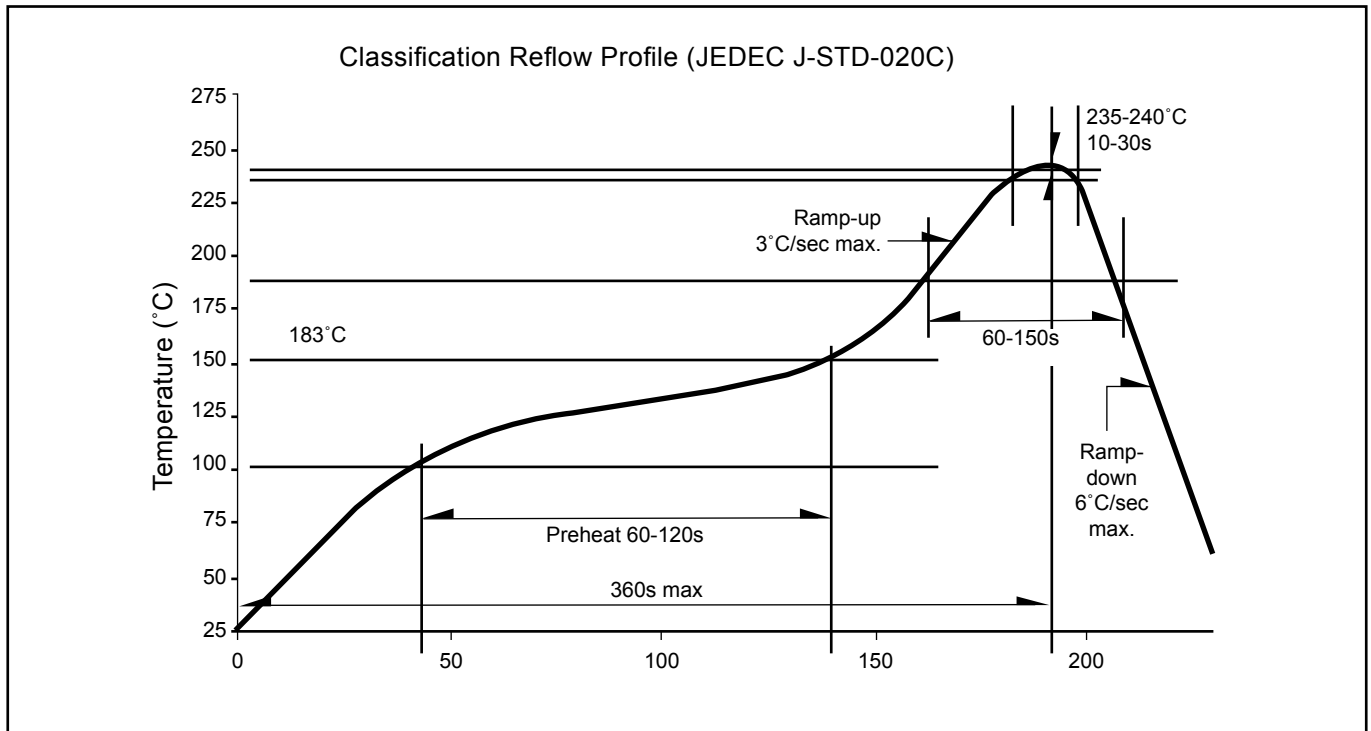

**Recommended Pb-free Soldering Profile**

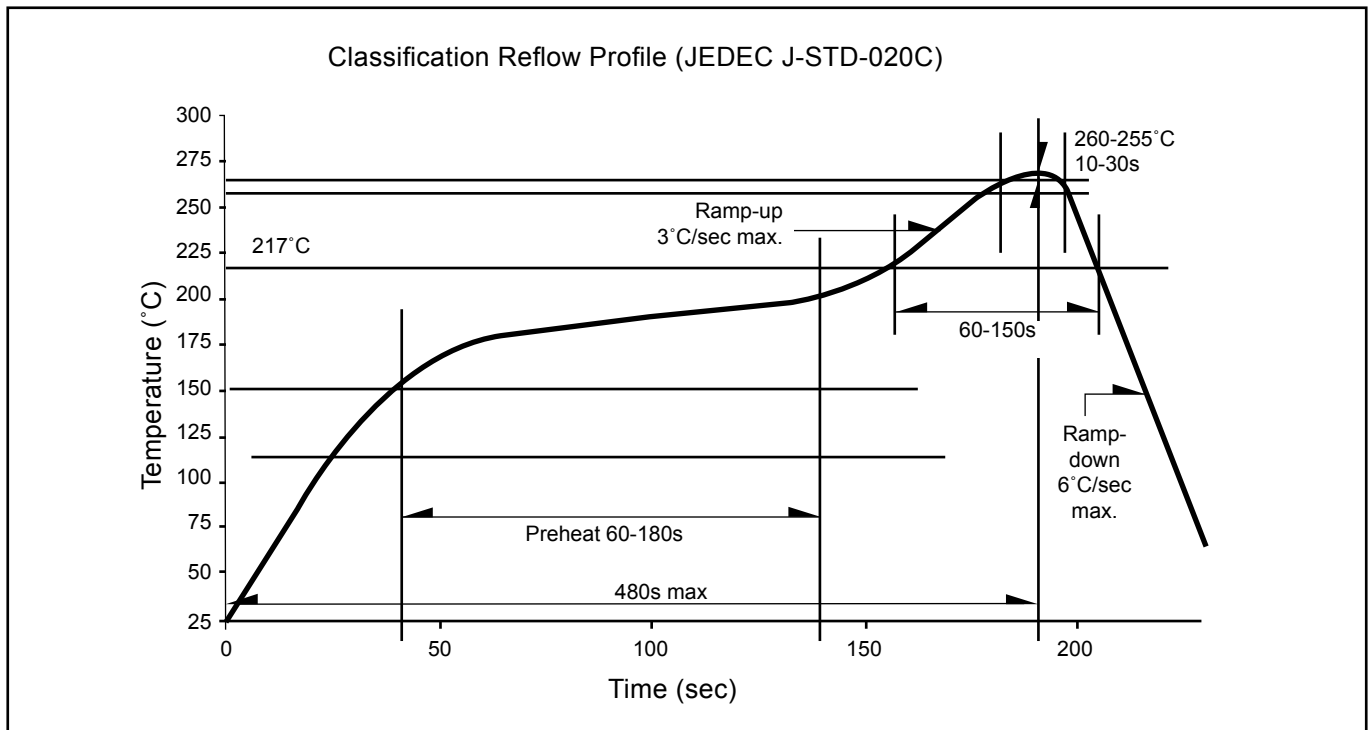

**Revision History**

Page	Subjects	Date of Modification
-	New Format	29 Sept 2005

**NOTE**

All the information contained in this document is considered to be reliable at the time of publishing. However, DOMINANT Semiconductors does not assume any liability arising out of the application or use of any product described herein.

DOMINANT Semiconductors reserves the right to make changes at any time without prior notice to any products in order to improve reliability, function or design.

DOMINANT Semiconductors products are not authorized for use as critical components in life support devices or systems without the express written approval from the Managing Director of DOMINANT Semiconductors.

