

MODEL NUMBER DHD05071

Coupler/Threshold Detector

FEATURES

- 5-50 MHz
- Integrated Coupler and Threshold Detector
- Adjustable Threshold Level
- 0.3 dB Hysteresis
- 1 mA Sink/Source Current
- 14 Pin Surface Mount Package
- See 1988 for DIP Version

TD

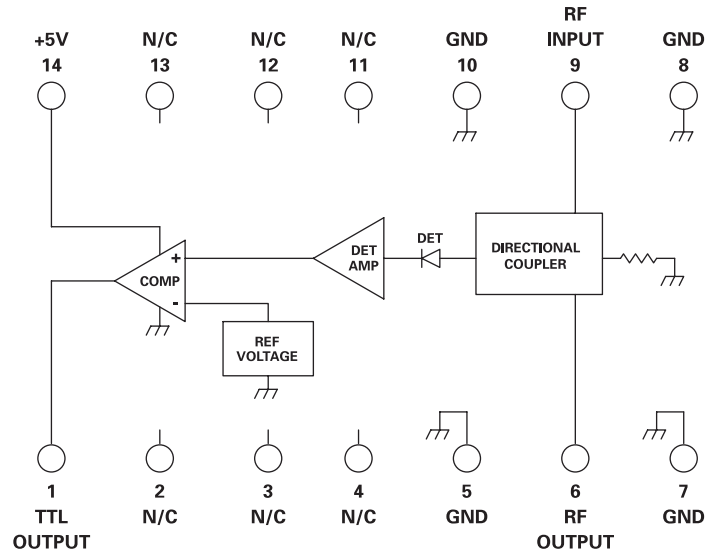
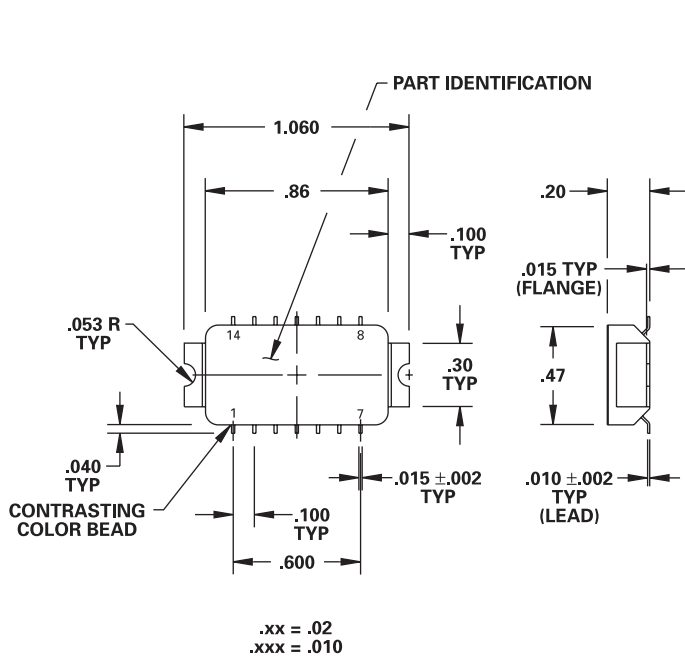

GUARANTEED PERFORMANCE

Parameter	Min	Typ	Max	Units	Conditions
Operating Frequency	5		50	MHz	
Threshold Level	-15	-12.4	-10	mA	Power into the Coupler
Hysteresis		0.3	1.2	dB	
Temperature Stability		±1.5		dB	
Insertion Loss		0.9	1.3	dB	
Input Flatness		±1.0		dB	
Response Time		8	300	µSec	90% / 10% RF to TTL Output
Input VSWR		1.1/1	1.5/1		
Output Current				mA	VOH = +2.7 V VOL = +0.5 V
	Source	1	2		
	Sink	1	10		
RF Power			+27	dBm	No Damage
DC Current		4	10	mA	At +5 V
Operating Temperature	-55	+25	+125	°C	TA

