



Low-Voltage Single SPDT Analog Switch

FEATURES

- Low Voltage Operation (1.8 V to 5.5 V)
- Low On-Resistance - r_{ON} : 3 Ω
- Fast Switching - t_{ON} : 20 ns, t_{OFF} : 10 ns
- Low Leakage - I_{COM} : 0.2-nA
- Low Charge Injection - Q_{INJ} : 5 pC
- Low Power Consumption
- TTL/CMOS Compatible
- ESD Protection > 2000 V (Method 3015.7)
- TSOP-6 Package

BENEFITS

- Reduced Power Consumption
- Simple Logic Interface
- High Accuracy
- Reduce Board Space

APPLICATIONS

- Cellular Phones
- Communication Systems
- Portable Test Equipment
- Battery Operated Systems
- Sample and Hold Circuits

DESCRIPTION

The DG2001 is a single-pole/double-throw monolithic CMOS analog switch designed for high performance switching of analog signals. Combining low power, high speed, low on-resistance and small physical size, the DG2001 is ideal for portable and battery powered applications requiring high performance and efficient use of board space.

The DG2001 is built on Vishay Siliconix's low voltage J12 process. The DG2001 has a minimum 2000-V, ESD protection, per Method 3015.7. An epitaxial layer prevents latchup. Break-before-make is guaranteed.

The switch conducts equally well in both directions when on, and blocks up to the power supply level when off.

FUNCTIONAL BLOCK DIAGRAM AND PIN CONFIGURATION

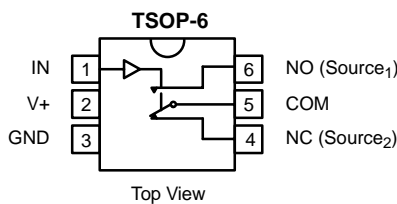

TRUTH TABLE		
Logic	NC	NO
0	ON	OFF
1	OFF	ON

ORDERING INFORMATION		
Temp Range	Package	Part Number
-40 to 85°C	TSOP-6	DG2001DV

ABSOLUTE MAXIMUM RATINGS

Reference to GND
 V+ -0.3 to +6 V
 IN, COM, NC, NO^a -0.3 to (V+ + 0.3 V)
 Continuous Current (Any terminal) ± 50 mA
 Peak Current ± 200 mA
 (Pulsed at 1 ms, 10% duty cycle)
 ESD (MIL-STD-883B, Method 3015.7) > 2000 V

Storage Temperature (D Suffix) -65 to 125°C
 Power Dissipation (Packages)^b
 TSOP-6^c 570 mW

Notes:
 a. Signals on NC, NO, or COM or IN exceeding V+ will be clamped by internal diodes. Limit forward diode current to maximum current ratings.
 b. All leads welded or soldered to PC Board.
 c. Derate 7.0 mW/°C above 25°C

SPECIFICATIONS (V+ = 2.0 V)							
Parameter	Symbol	Test Conditions Otherwise Unless Specified V+ = 2.0 V, ± 10%, V _{IN} = 0.4 or 1.6 V ^e	Temp ^a	Limits -40 to 85°C			Unit
				Min ^b	Typ ^c	Max ^b	
Analog Switch							
Analog Signal Range ^d	V _{NO} , V _{NC} , V _{COM}		Full	0		V+	V
On-Resistance	r _{ON}	V+ = 1.8 V, V _{COM} = 1.0 V, I _{NO} , I _{NC} = 10 mA	Room Full		15 17	30 32	Ω
r _{ON} Flatness ^d	r _{ON} Flatness	V+ = 1.8 V, V _{COM} = 0 to V+, I _{NO} , I _{NC} = 10 mA	Room		5		
Switch Off Leakage Current ^g	I _{NO(off)} , I _{NC(off)}	V+ = 2.2 V V _{NO} , V _{NC} = 0.5 V/1.5 V, V _{COM} = 1.5 V/0.5 V	Room Full	-300 -3.5		300 3.5	pA nA
	I _{COM(off)}		Room Full	-300 -3.5		300 3.5	pA nA
Channel-On Leakage Current ^g	I _{COM(on)}	V+ = 2.2 V, V _{NO} , V _{NC} = V _{COM} = 0.5 V/1.5 V	Room Full	-350 -3.5		300 3.5	pA nA
Digital Control							
Input High Voltage	V _{INH}		Full	1.6			V
Input Low Voltage	V _{INL}		Full			0.4	
Input Capacitance	C _{in}		Full		4		pF
Input Current	I _{INL} or I _{INH}	V _{IN} = 0 or V+	Full	1		1	μA
Dynamic Characteristics							
Turn-On Time	t _{ON}	V _{NO} or V _{NC} = 1.5 V, R _L = 300 Ω, C _L = 35 pF	Room Full		30	50 53	ns
Turn-Off Time	t _{OFF}		Room Full		15	30 33	
Break-Before-Make Time	t _d		Room	1	15		
Charge Injection ^d	Q _{INJ}	C _L = 1 nF, V _{GEN} = 0 V, R _{GEN} = 0 Ω	Room		1	10	pC
Off-Isolation ^d	OIRR	R _L = 50 Ω, C _L = 5 pF, f = 1 MHz	Room		-71		dB
Crosstalk ^d	X _{TALK}		Room		-70		
No, Nc Off Capacitance ^d	C _{NO(off)} , C _{NC(off)}	V _{IN} = 0 or V+, f = 1 MHz	Room		17		pF
Channel-On Capacitance ^d	C _{ON}		Room		50		
Power Supply							
Power Supply Range	V+	V _{IN} = 0 or V+		1.8		2.20	V
Power Supply Current	I+				0.01	1.0	μA
Power Consumption	P _C					2.2	μW



SPECIFICATIONS (V+ = 3 V)							
Parameter	Symbol	Test Conditions Otherwise Unless Specified V+ = 3 V, ±10%, VIN = 0.4 or 2.0 V ^e	Temp ^a	Limits -40 to 85°C			Unit
				Min ^b	Typ ^c	Max ^b	
Analog Switch							
Analog Signal Range ^d	V _{NO} , V _{NC} , V _{COM}		Full	0		V+	V
On-Resistance	r _{ON}	V+ = 2.7 V, V _{COM} = 1.5 V, I _{NO} , I _{NC} = 10 mA	Room Full		5 6	9.2 10.2	Ω
r _{ON} Flatness ^d	r _{ON} Flatness	V+ = 2.7 V V _{COM} = 0 to V+, I _{NO} , I _{NC} = 10 mA	Room		3		
Switch Off Leakage Current ^g	I _{NO(off)} , I _{NC(off)}	V+ = 3.3 V, V _{NO} , V _{NC} = 1 V/3 V V _{COM} = 3 V/1 V	Room Full	-400 -4.5		400 4.5	pA nA
	I _{COM(off)}		Room Full	-400 -4.5		400 4.5	pA nA
Channel-On Leakage Current ^g	I _{COM(on)}	V+ = 3.3 V, V _{NO} , V _{NC} = V _{COM} = 1 V/3 V	Room Full	-450 -4.5		450 4.5	pA nA
Digital Control							
Input High Voltage	V _{INH}		Full	2			V
Input Low Voltage	V _{INL}		Full			0.4	
Input Capacitance	C _{in}		Full		4		pF
Input Current	I _{INL} or I _{INH}	V _{IN} = 0 or V+	Full	1		1	μA
Dynamic Characteristics							
Turn-On Time	t _{ON}	V _{NO} or V _{NC} = 2.0 V, R _L = 300 Ω, C _L = 35 pF	Room Full		24	45 48	ns
Turn-Off Time	t _{OFF}		Room Full		12	30 33	
Break-Before-Make Time	t _d		Room	1	13		
Charge Injection ^d	Q _{INJ}	C _L = 1 nF, V _{GEN} = 0 V, R _{GEN} = 0 Ω	Room		3	10	pC
Off-Isolation ^d	OIRR	R _L = 50 Ω, C _L = 5 pF, f = 1 MHz	Room		-71		dB
Crosstalk ^d	X _{TALK}		Room		-70		
N _O , N _C Off Capacitance ^d	C _{NO(off)} , C _{NC(off)}	V _{IN} = 0 or V+, f = 1 MHz	Room		17		pF
Channel-On Capacitance ^d	C _{ON}		Room		50		
Power Supply							
Power Supply Range	V+			2.7		3.3	V
Power Supply Current	I+	V _{IN} = 0 or V+			0.01	1.0	μA
Power Consumption	P _C						3.3

SPECIFICATIONS (V+ = 5 V)							
Parameter	Symbol	Test Conditions Otherwise Unless Specified V+ = 5 V, ±10%, VIN = 0.8 or 2.4 V ^e	Temp ^a	Limits -40 to 85°C			Unit
				Min ^b	Typ ^c	Max ^b	
Analog Switch							
Analog Signal Range ^d	V _{NO} , V _{NC} , V _{COM}		Full	0		V+	V
On-Resistance	r _{ON}	V+ = 4.5 V, V _{COM} = 3 V, I _{NO} , I _{NC} = 10 mA	Room Full		3 4	7.0 8.0	Ω
r _{ON} Flatness ^d	r _{ON} Flatness	V+ = 4.5 V, V _{COM} = 0 to V+, I _{NO} , I _{NC} = 10 mA	Room		2		
Switch Off Leakage Current ^g	I _{NO(off)} , I _{NC(off)}	V+ = 5.5 V V _{NO} , V _{NC} = 1 V/4.5 V, V _{COM} = 4.5 V/1 V	Room Full	-900 -5.5		900 5.5	pA nA
	I _{COM(off)}		Room Full	-900 -5.5		900 5.5	pA
Channel-On Leakage Current ^g	I _{COM(on)}	V+ = 5.5 V, V _{NO} , V _{NC} = V _{COM} = 1 V/4.5 V	Room Full	-1000 -5.5		1000 5.5	pA nA
Digital Control							
Input High Voltage	V _{INH}		Full	2.4			V
Input Low Voltage	V _{INL}		Full			0.8	
Input Capacitance	C _{in}		Full		4		pF
Input Current	I _{INL} or I _{INH}	V _{IN} = 0 or V+	Full	1		1	μA
Dynamic Characteristics							
Turn-On Time	t _{ON}	V _{NO} or V _{NC} = 3 V, R _L = 300 Ω, C _L = 35 pF	Room Full		20	37 40	ns
Turn-Off Time	t _{OFF}		Room Full		10	27 30	
Break-Before-Make Time	t _d		Room	1	10		
Charge Injection ^d	Q _{INJ}	C _L = 1 nF, V _{GEN} = 0 V, R _{GEN} = 0 Ω	Room		7	10	pC
Off-Isolation ^d	OIRR	R _L = 50 Ω, C _L = 5 pF, f = 1 MHz	Room		-71		dB
Crosstalk ^d	X _{TALK}		Room		-70		
Source-Off Capacitance ^d	C _{NO(off)} , C _{NC(off)}	V _{IN} = 0 or V+, f = 1 MHz	Room		17		pF
Channel-On Capacitance ^d	C _{ON}		Room		50		
Power Supply							
Power Supply Range	V+			4.5		5.5	V
Power Supply Current	I+	V _{IN} = 0 or V+			0.01	1.0	μA
Power Consumption	P _C						5.5

Notes:

- Room = 25°C, Full = as determined by the operating suffix.
- Typical values are for design aid only, not guaranteed nor subject to production testing.
- The algebraic convention whereby the most negative value is a minimum and the most positive a maximum, is used in this data sheet.
- Guarantee by design, not subjected to production test.
- V_{IN} = input voltage to perform proper function.
- Guaranteed by 5-V leakage testing, not production tested.

TYPICAL CHARACTERISTICS (25°C UNLESS NOTED)

r_{ON} vs. V_{COM} and Supply Voltage

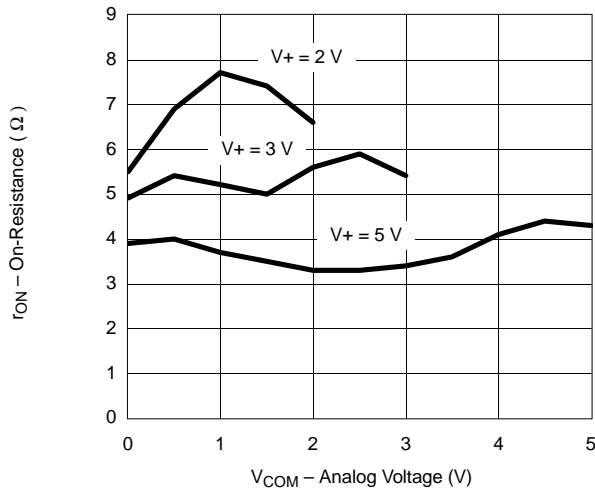

r_{ON} vs. Analog Voltage and Temperature

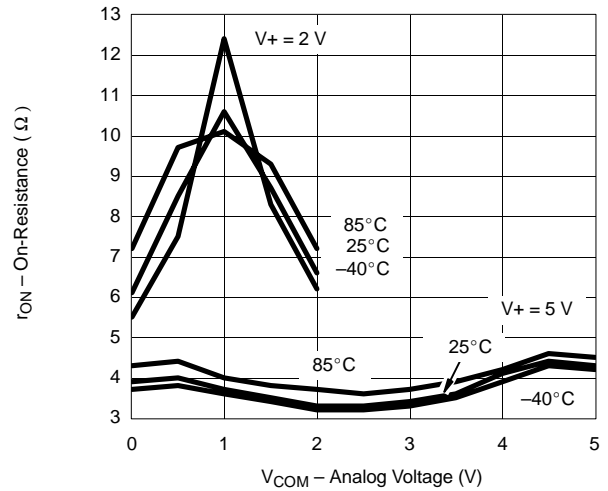

Supply Current vs. Temperature

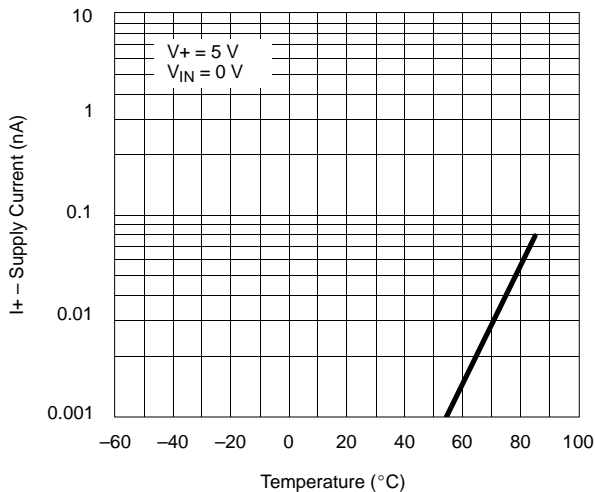

Supply Current vs. Input Switching Frequency

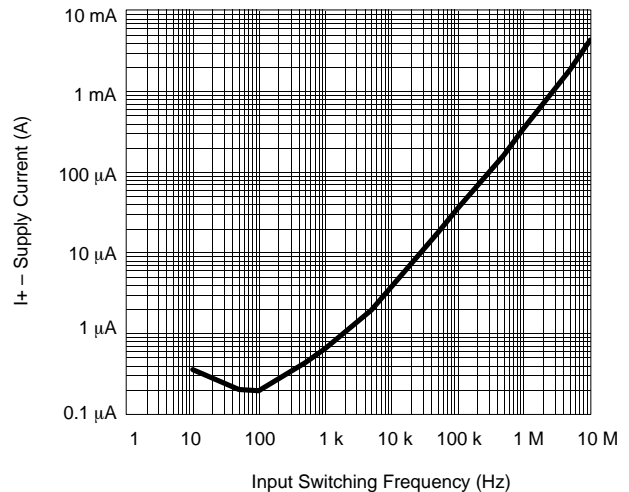

Leakage Current vs. Temperature

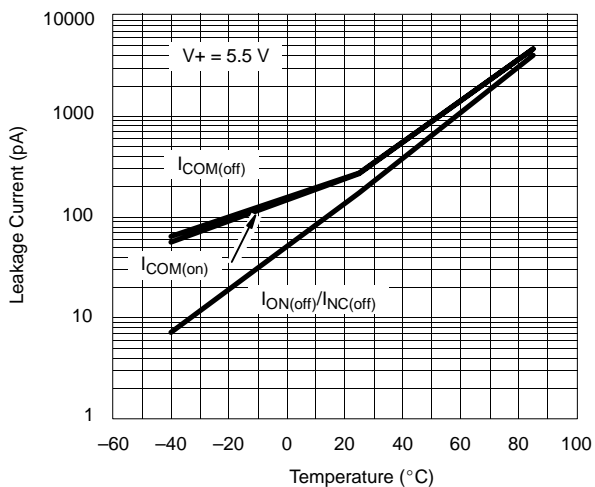

Leakage vs. Analog Voltage

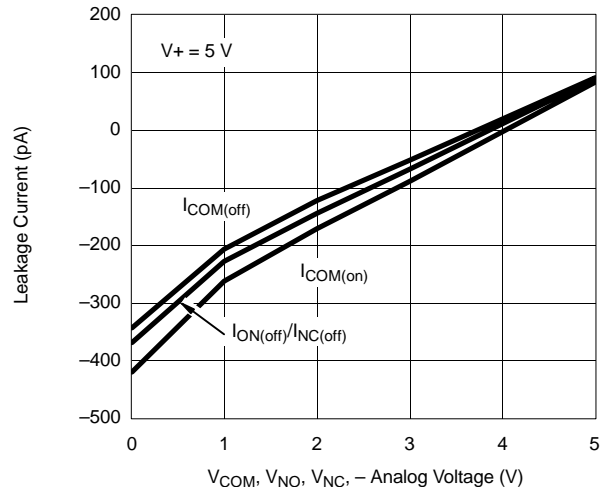

TYPICAL CHARACTERISTICS (25 °C UNLESS NOTED)

Switching Time vs. Temperature and Supply Voltage

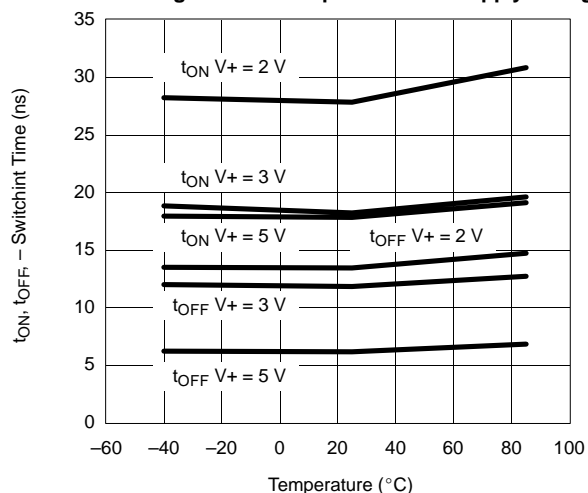

Insertion Loss, Off-Isolation, Crosstalk vs. Frequency

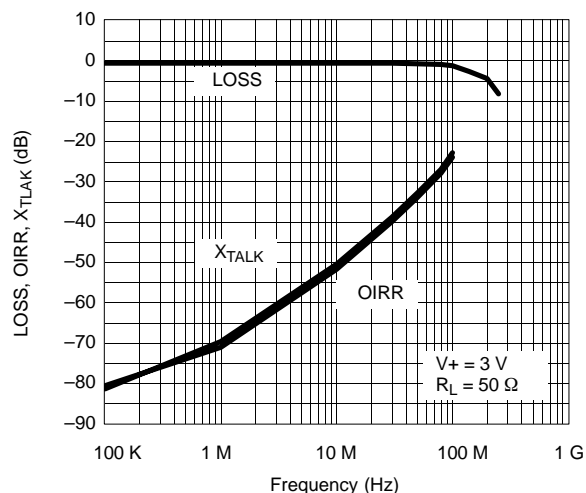

Switching Threshold vs. Supply Voltage

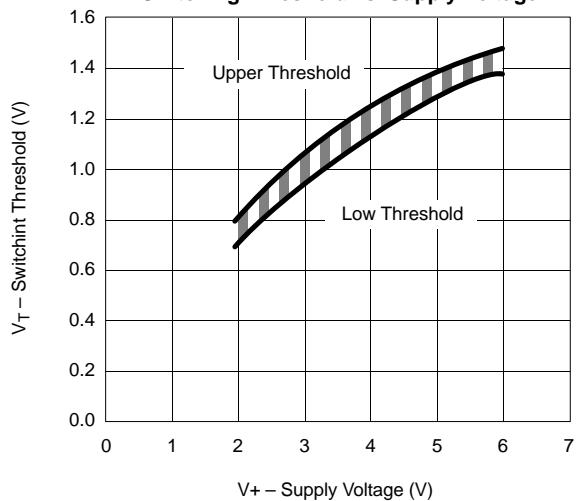

Charge Injection vs. Analog Voltage

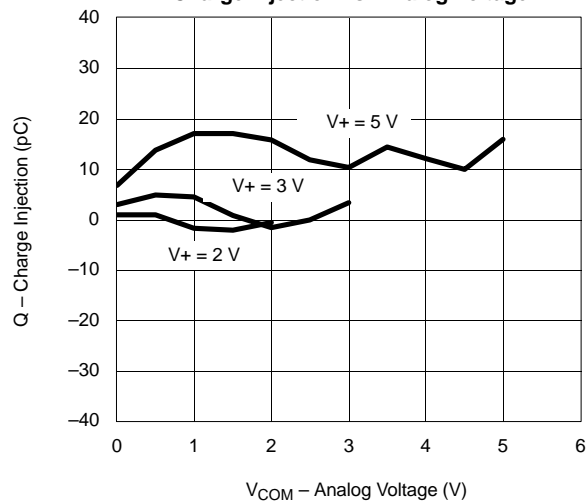

TEST CIRCUITS

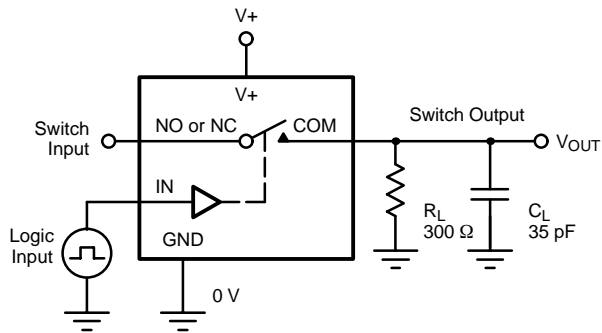

C_L (includes fixture and stray capacitance)

$$V_{OUT} = V_{COM} \left(\frac{R_L}{R_L + R_{ON}} \right)$$

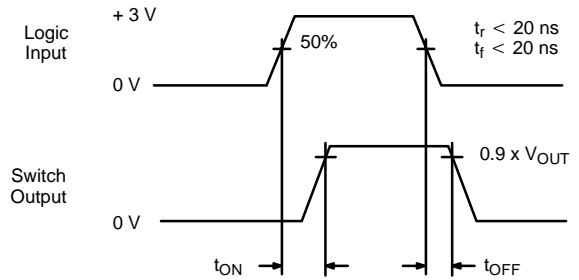

Logic "1" = Switch On
Logic input waveforms inverted for switches that have the opposite logic sense.

FIGURE 1. Switching Time

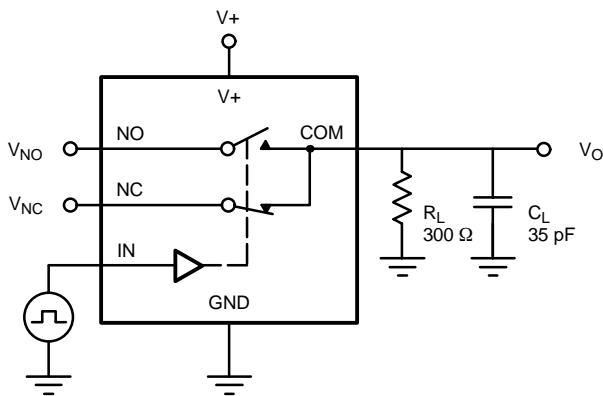

C_L (includes fixture and stray capacitance)

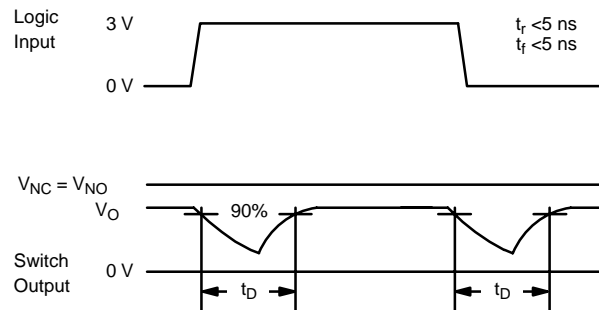
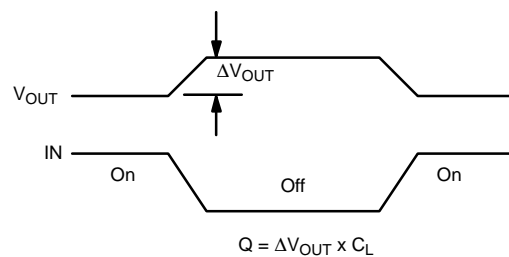
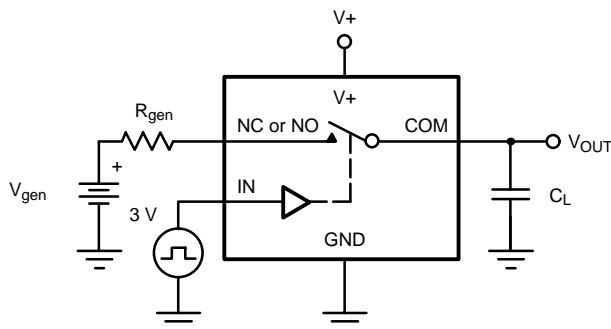

FIGURE 2. Break-Before-Make Interval



IN depends on switch configuration: input polarity determined by sense of switch.

FIGURE 3. Charge Injection

TEST CIRCUITS

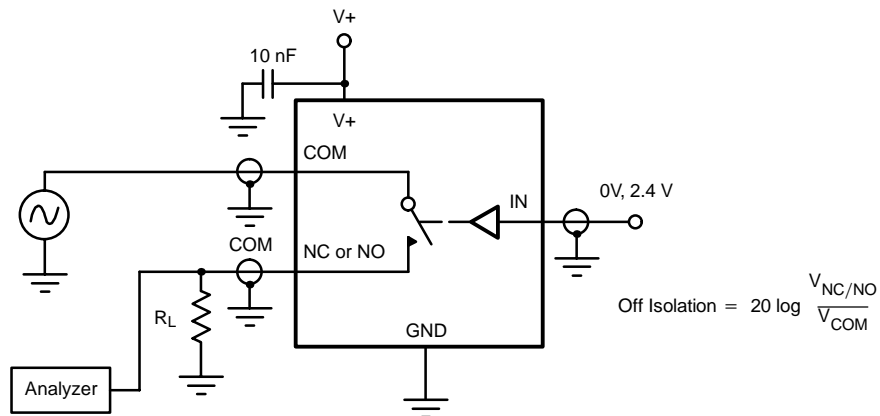

FIGURE 4. Off-Isolation

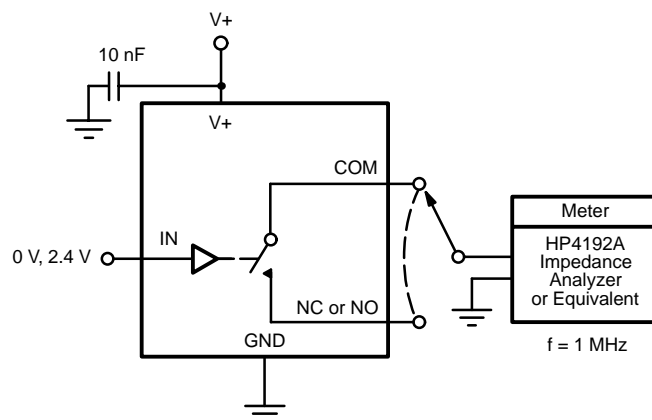

FIGURE 5. Channel Off/On Capacitance