

DomiLED – AlGaAs: DDH-GRS

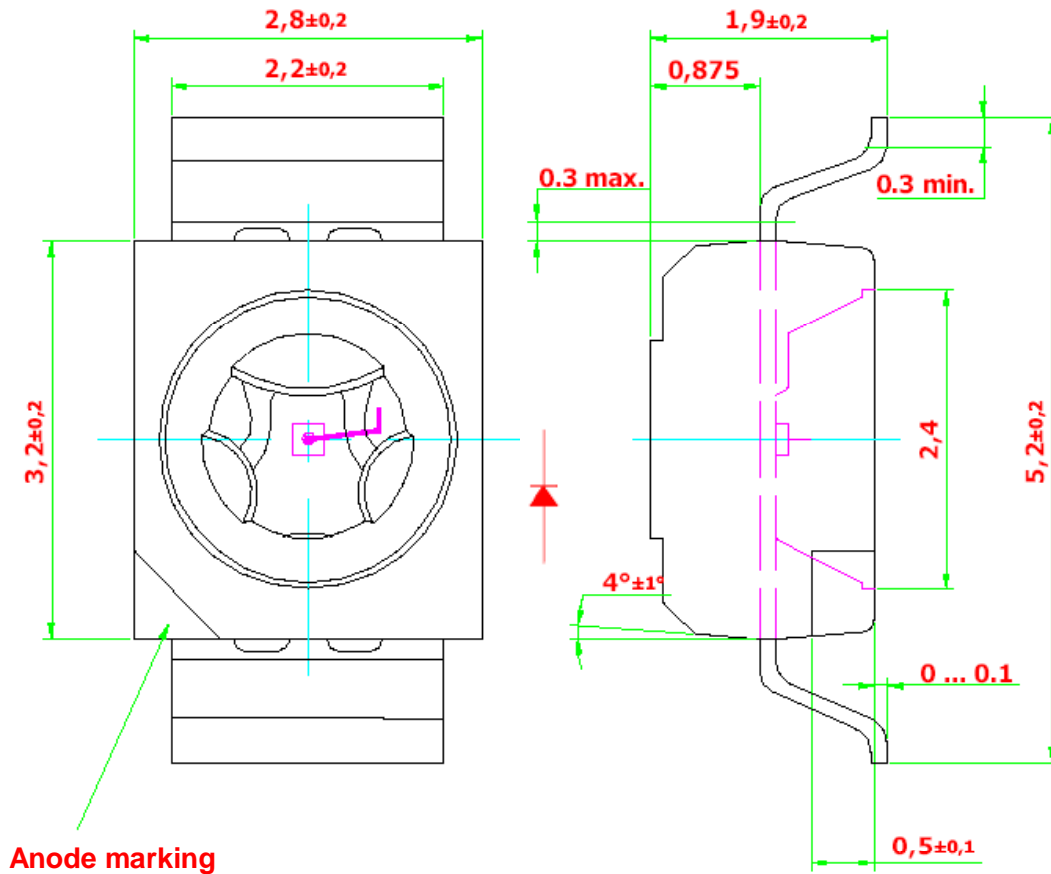

- Surface mount LED.
- 120° viewing angle.
- Small package outline (LxWxH) of 3.2 x 2.8 x 1.8 mm.
- Qualified according to JEDEC moisture sensitivity Level 2.
- Compatible to both IR reflow soldering and TTW soldering.

DOMINANT Semiconductors

Part Ordering Number	Chip Technology / Color (dom. WL)	Luminous Intensity @ If = 20mA Iv (mcd)
DDH-GRS-MN2-1	AlGaAs/ Hyper Red, 645 nm	18.0 ... 45.0
• DDH-GRS-M1		18.0 ... 22.4
• DDH-GRS-M2		22.4 ... 28.5
• DDH-GRS-N1		28.5 ... 35.5
• DDH-GRS-N2		35.5 ... 45.0
DDH-GRS-NP2-1		28.5 ... 71.5
• DDH-GRS-N1		28.5 ... 35.5
• DDH-GRS-N2		35.5 ... 45.0
• DDH-GRS-P1		45.0 ... 56.0
• DDH-GRS-P2		56.0 ... 71.5

NOTE:

1. All part number above comes in a quantity of 2000 units per reel.
2. Other luminous intensity groups are also available upon request.
3. Luminous intensity is measured with an accuracy of $\pm 11\%$.
4. Wavelength binning is carried for all units as per the wavelength-binning table. Only one wavelength group is allowed for each reel.
5. An optional Vf binning is also available upon request. Binning scheme is as per following table.

Characteristics.

Forward voltage @ If=20 mA.	Chip Type	Viewing angle at 50% Iv	Reverse current, I _R @ V _R = 5V, (max)
1.9 V (typ.); 2.6 V (max)	AlGaAs	120°	100 μ A

Wavelength Grouping.

Color	Group	Wavelength distribution (nm)
DDH; Hyper Red	Full	640 – 650

Dominant wavelength is measured with an accuracy of ± 1 nm.

Vf Binning.

Vf Bin @ 20mA	Forward voltage (V)
01	1.55 ... 1.85
02	1.85 ... 2.15
03	2.15 ... 2.45
04	2.45 ... 2.60

Forward voltage, Vf is measured with an accuracy of ± 0.1 V.

Absolute Maximum Ratings.

	Maximum Value	Unit
DC forward current.	30	mA
Peak pulse current; ($t_p \leq 10 \mu s$, Duty cycle = 0.005)	500	mA
Reverse voltage.	5	V
LED junction temperature.	100	$^{\circ}C$
Operating temperature.	-40 ... +100	$^{\circ}C$
Storage temperature.	-40 ... +100	$^{\circ}C$
Power dissipation (at room temperature)	75	mW

Recommended Solder Pad

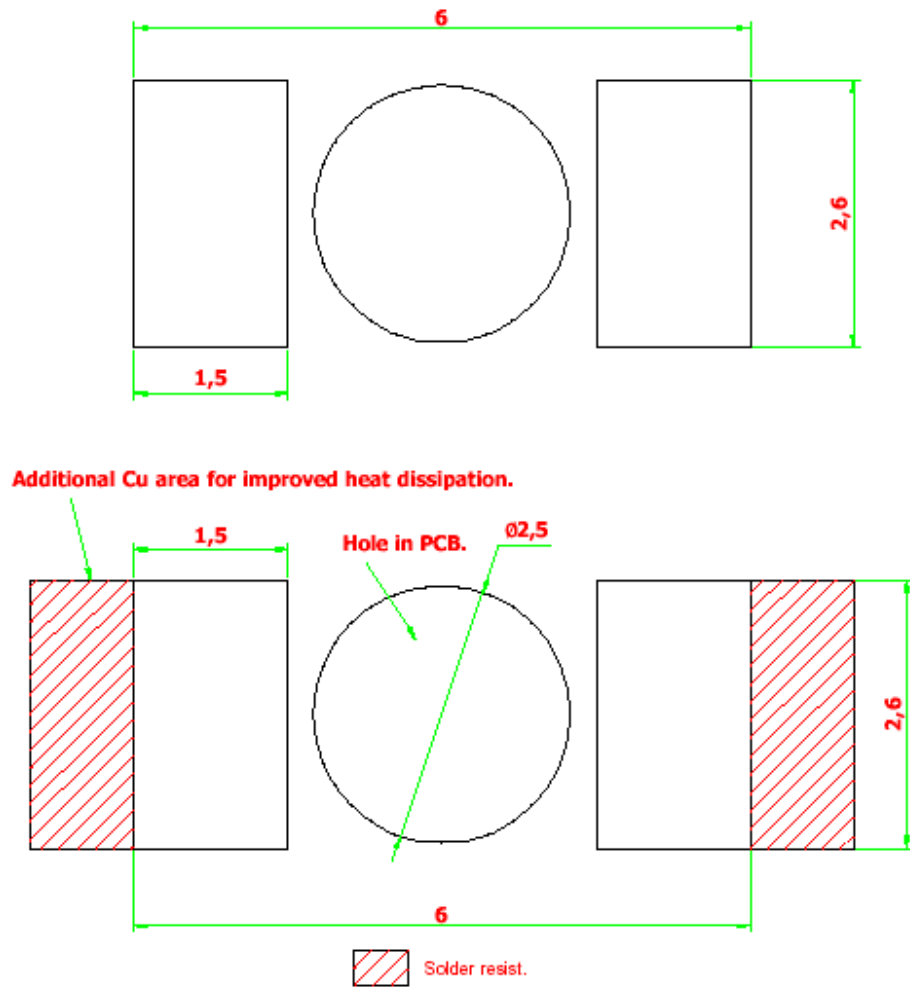

DOMINANT Semiconductors

Relative luminous intensity vs. forward current.

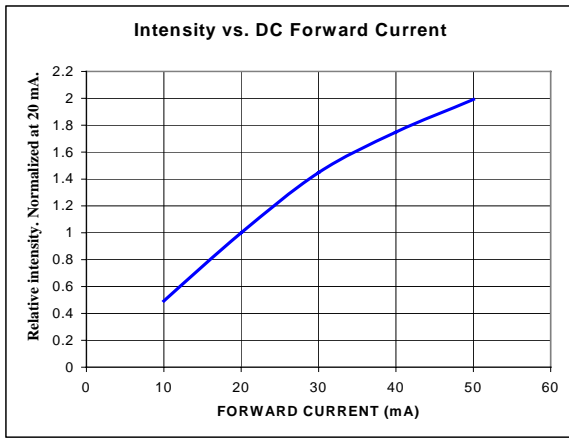

Forward current vs. forward voltage.

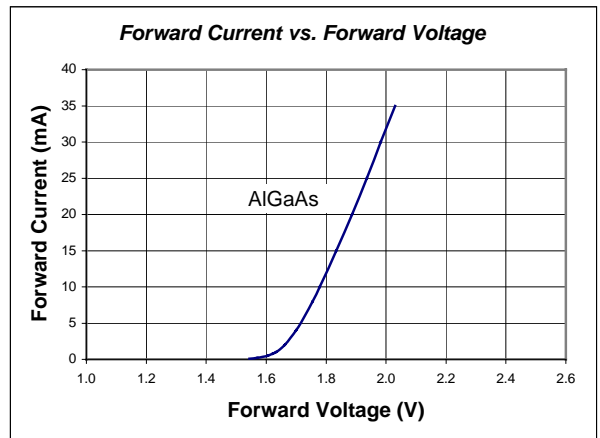

Radiation pattern.

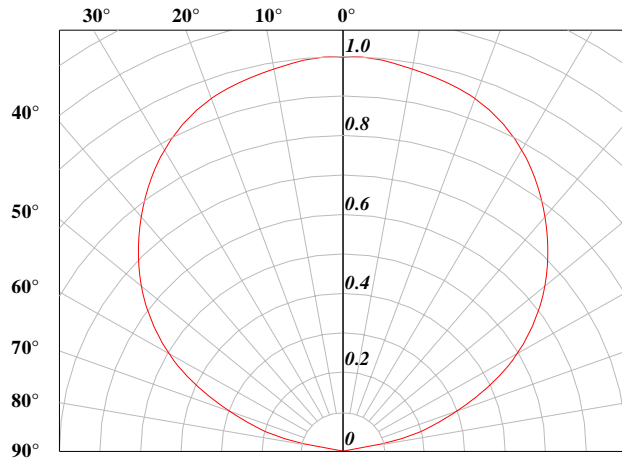

Maximum forward current vs. temperature.

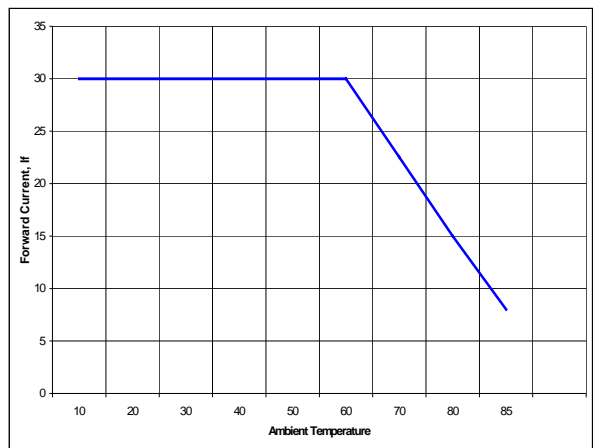

Taping And Orientation.

Reels come in quantity of 2000 units.

Reel diameter is 180 mm.

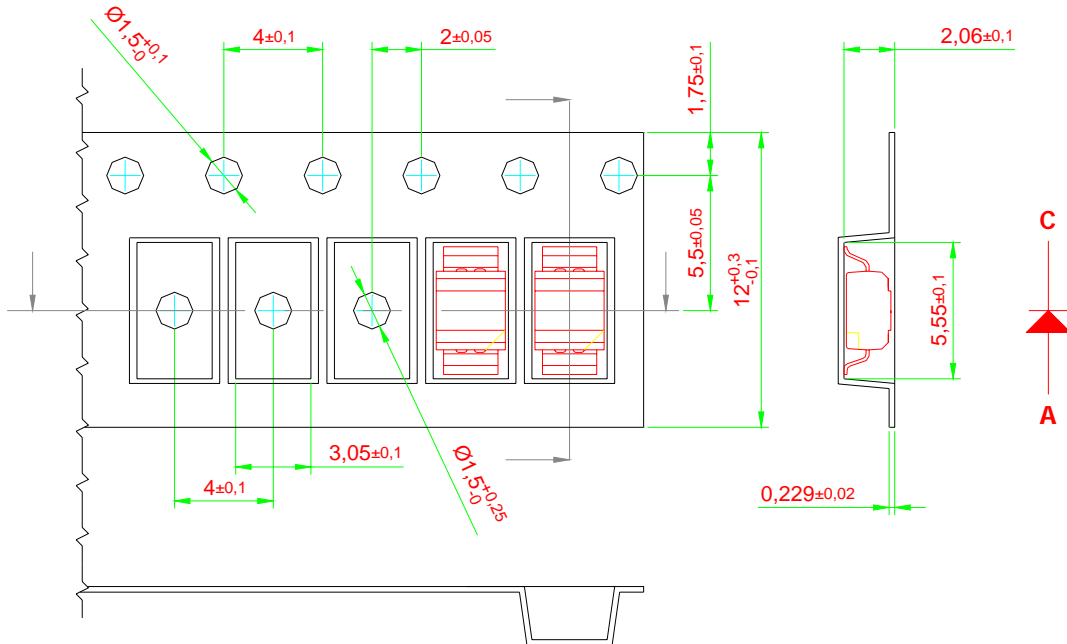

200 mm min. for Ø180 reel.

480 mm min. for Ø180 reel.

200 mm min. for Ø330 reel.

960 mm min. for Ø330 reel.

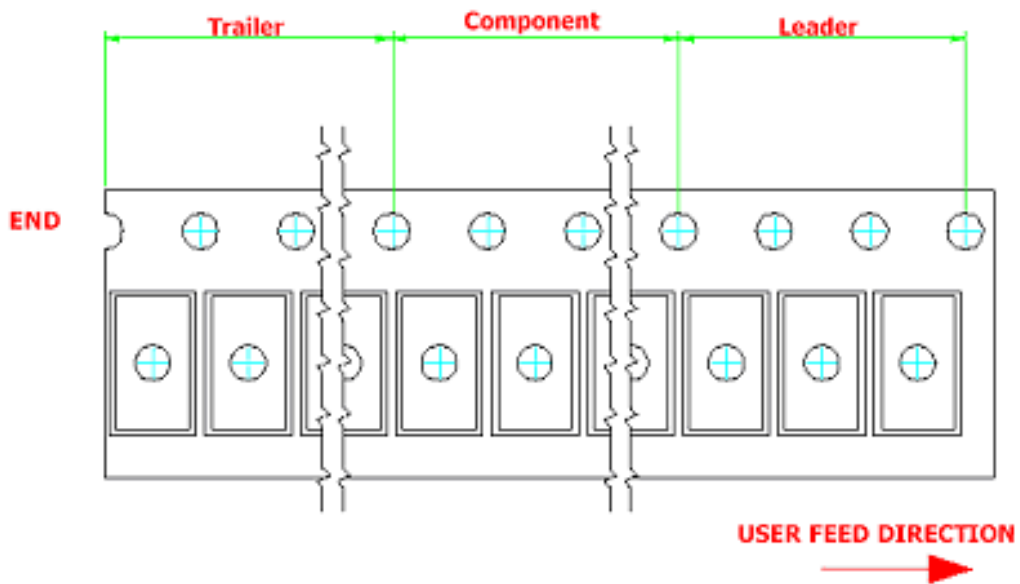

Recommended Sn-Pb IR-Reflow Soldering Profile.

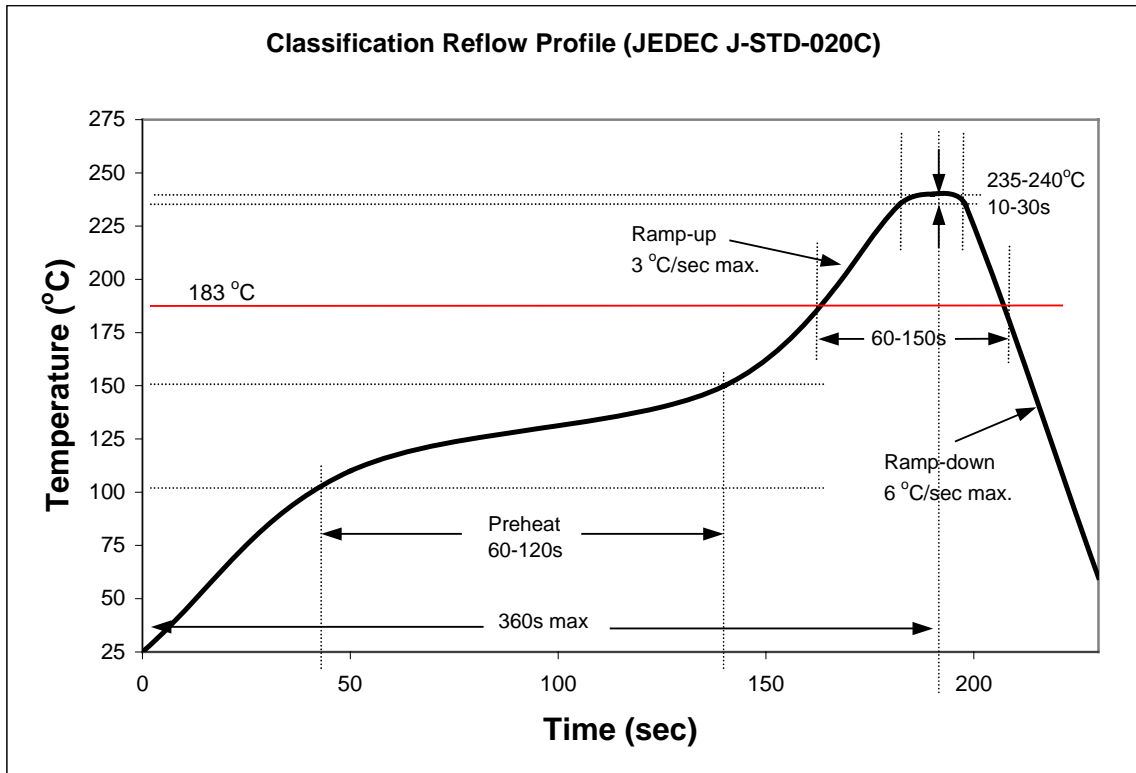

Recommended Pb Free IR-Reflow Soldering Profile.

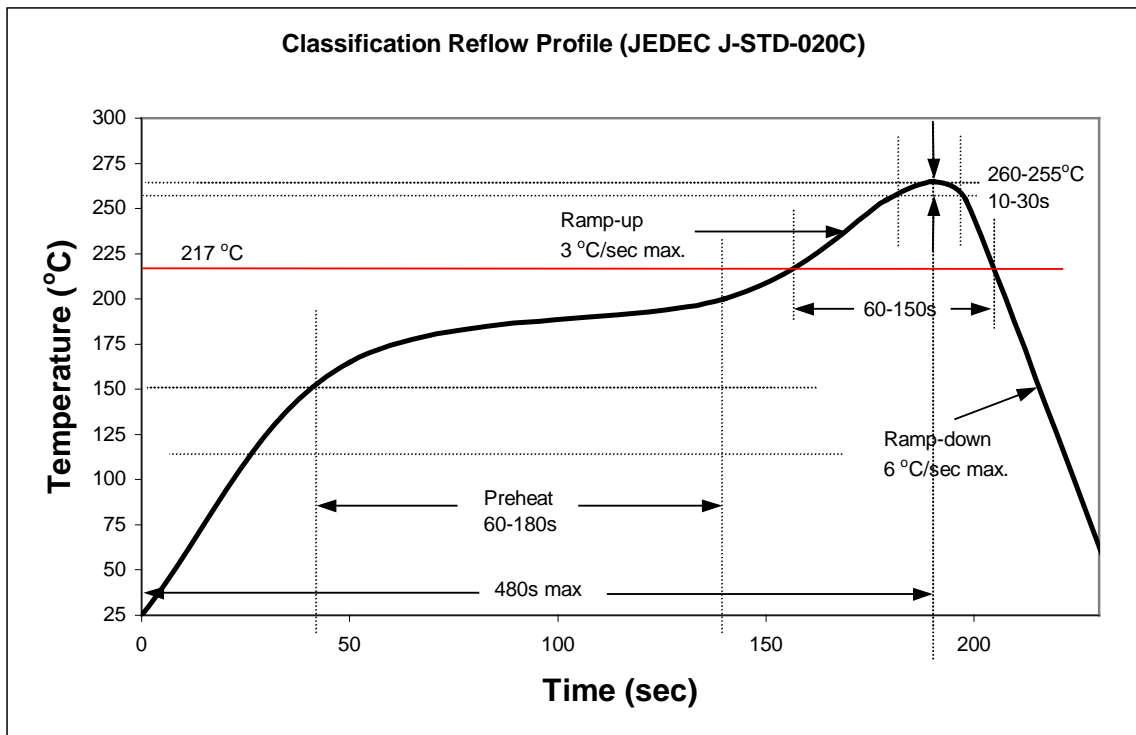

NOTE.

All the information published is considered to be reliable. However, DOMINANT Semiconductors does not assume any liability arising out of the application or use of any product described herein.

DOMINANT Semiconductors reserves the right to make changes at any time without notice to any products in order to improve reliability, function or design.

DOMINANT Semiconductors products are not authorized for use as critical components in life support devices or systems without the express written approval from the managing director of DOMINANT Semiconductors.