

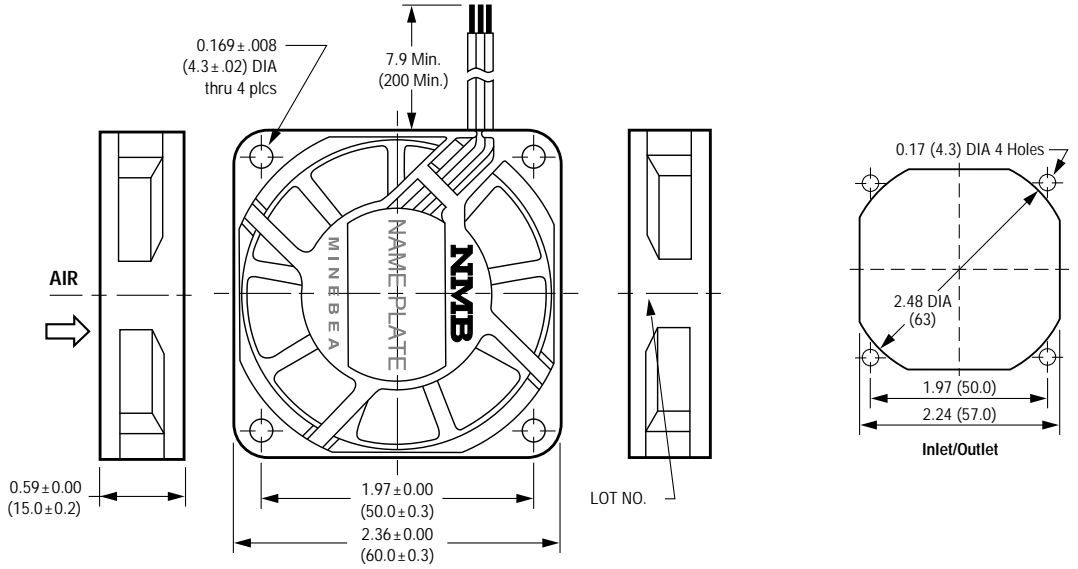

FEATURES/ BENEFITS

- Size: 2.36 in sq. X 0.59 in (60mm sq. X 15mm)
- Low Noise Levels: 19 ~ 34 dB(A)
- Low Weight: 1.59 oz (45g)
- Long life and quiet operation guaranteed by dual ball bearing design
- Temperature range: -10°C to +70°C (operating range)
- Meets UL/CSA, VDE, CE requirements
- Airflow: 7 ~ 19 CFM
- Lead Wires: AWG 26, Red/Black/UL1007
- Applications: Pentium™ Class Notebooks, Set Top Boxes, Docking Stations, and Telephone Packs



Dimensions are in inches. () are in millimeters

Model Number	Operating Voltage	Rated Voltage	Max. Air Flow ¹	Max. Static Pressure ¹	Speed ¹	Current	Input Power	Noise
		V	m ³ /min	Pa	rpm	A	W	dB
2406KL-04W-B10-L00	7-13.8	12	0.19	8.5	1800	0.04	0.48	19
2406KL-04W-B20-L00	6-13.8	12	0.33	23.4	3100	0.07	0.84	25
2406KL-04W-B30-L00	6-13.8	12	0.40	31.3	3600	0.09	1.08	28
2406KL-04W-B40-L00	6-13.8	12	0.45	39.7	4100	0.13	1.56	31
2406KL-04W-B50-L00	6-13.8	12	0.52	51.2	4600	0.16	1.92	34

¹) Average values

Air Flow Curves

